

# Relay Terminal G7VC



CSM\_G7VC\_DS\_E\_1\_1

## Compact Output Relay Terminals and Output SSR Terminals Let You Connect to the Machine Controller Output with One Cable.

- Compact size: 192 (W) × 58 (D) × 38.5 (42.5) (H) mm.
- Ideal for adding outputs to single-board computers, NC controllers, and PLCs.
- New design with rotating front cover for increased safety.
- Direct connection of wiring to loads.
- LED operation indicators.
- Equipped with relay removal tool.
- DIN Track or screw mounting.

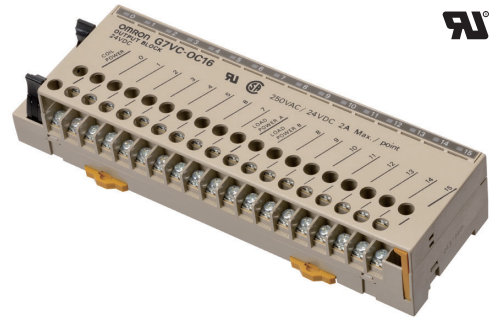

For the most recent information on models that have been certified for safety standards, refer to your OMRON website.

## Ordering Information

### Relay Terminals

When ordering, specify the rated voltage.

I/O classification	Points	Internal I/O common	Rated voltage	Model
Relay outputs	16 (SPST-NO × 16)	NPN (+ common)	24 VDC	<b>G7VC-OC16</b>
		PNP (- common)		<b>G7VC-OC16-1</b>
SSR AC outputs		NPN (+ common)		<b>G7VC-OA16</b>
SSR DC outputs		NPN (+ common)		<b>G7VC-OD16</b>

## Accessories (Order Separately)

### Cables for I/O Relay Terminals

- Cables with Loose Wires and Crimp Terminals: XW2Z-RY□□C
  - Cables with Loose Wires: XW2Z-RA□□C
  - Cables with Connectors (1:3): XW2Z-R□□C-□
  - Cables with Connectors (1:2): XW2Z-RO□□C
  - Cables with Connectors (1:1): XW2Z-R□□C
- Refer to the XW2Z-R Datasheet for details.

### Shorting Bar

Model
<b>G78-V02</b>

### Accessories for DIN Track Mounting

Refer to your OMRON website for details on the PFP-□.

## Model Number Legend

G7VC-□□□□-□  
1 2 3 4

1. Input/Output Classification  
O: For output
2. Type of I/O Signal  
A: SSR AC output  
D: SSR DC output  
C: Contact output
3. Number of Output Points  
16: 16 points

4. Internal I/O common  
Blank: NPN

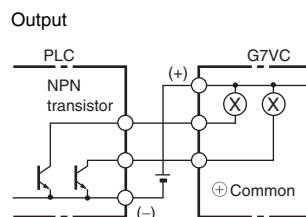

- 1: PNP

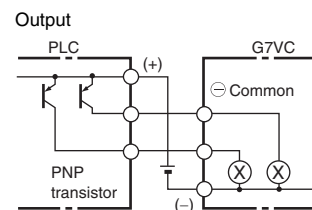

## Specifications

### Ratings

#### Relay Specifications

The following values are for when the Relay is mounted on the G7VC Relay Terminal. The values are different from those for an individual G6B-1174P-FD-US DC24V Relay.

#### Operating Coil

(Per one G6B-1174P-FD-US DC24V Relay mounted on the Relay Terminal)

Rated voltage (V)	Rated current (mA)	Coil resistance ( $\Omega$ )	Must-operate of rated voltage	Must-re-lease of rated voltage	Maximum of rated voltage	Power consumption (W)	
						Per 1 point	Per 16 points
24 VDC	8.3	2,880	80% max.	10% min.	110%	Approx. 0.2	Approx. 3.2

- Note:**
1. The rated current and coil resistance are measured at a coil temperature of 23°C with a tolerance of  $\pm 15\%$  for coil resistance.
  2. The operating characteristics are measured at a coil temperature of 23°C.
  3. The value for the maximum voltage is the maximum value within the allowable voltage fluctuation range for the relay coil's operating power supply. Continuous operation at this voltage is not within product specifications.
  4. Approx. 4 mA flows into each LED indicator. To calculate the power supply capacity, add the power value of each LED indicator.

#### SSR Specifications

##### Input

Type	Model	Rated voltage	Must-operate voltage level	Must-re-lease voltage level	Input impedance
For AC output	G3S-201PL-PD	24 VDC	19.2 VDC max.	1 VDC min.	2.2 k $\Omega$ $\pm 20\%$
For DC output	G3SD-Z01P-PD				2.8 k $\Omega$ $\pm 20\%$

##### Output

Type	Model	Load voltage	Load current	Inrush current
For AC output	G3S-201PL-PD	3 to 264 VAC	0.1 to 0.5 A	15 A (60 Hz, 1 cycle)
For DC output	G3SD-Z01P-PD	3 to 125 VDC	0.01 A to 0.5 A	3 A (10 ms)

#### Contact Ratings

Item	Resistive load ( $\cos \phi = 1$ )	Inductive load ( $\cos \phi = 0.4, L/R = 7$ ms)
Rated load	2 A at 220 VAC 2 A at 24 VDC	0.8 A at 220 VAC 0.8 A at 24 VDC
Rated carry current	2 A (per one Relay), 8 A per 8-point common terminal, and 16 A per 16-point common terminal	
Max. switching voltage	250 VAC, 125 VDC	
Max. switching current	2 A	0.8 A
Error rate (reference value)*	10 mA at 5 V	
Electrical endurance	200,000 operations	
Mechanical endurance	50,000,000 operations	

\*The above values are for a switching frequency of 120 operations/min.

## Characteristics

### Relay Outputs

Model		G7VC-OC16/G7VC-OC16-1
Item		
Contact form		16 (SPST-NO × 16)
Contact mechanism		Single contact
Contact material		AgInSn
Contact resistance *1		50 mΩ max.
Must operate time *2		15 ms max.
Release time *2		15 ms max.
Max. switching frequency	Mechanical limit	18,000 operations/hour
	At rated load	1,800 operations/hour
Insulation resistance		100 MΩ min. (at 500 VDC)
Dielectric strength	Between coil and contact	2,000 VAC, 50/60 Hz for 1 minute
	Between same polarity contacts	1,000 VAC, 50/60 Hz for 1 minute
	Between paired connectors	250 VAC, 50/60 Hz for 1 minute
Vibration resistance		10 to 55 to 10 Hz with 1.0-mm double amplitude
Shock resistance		200 m/s <sup>2</sup>
Noise immunity		Noise level: 1.5 kV; pulse width: 100 ns to 1 μs
Rated voltage between positive and negative terminal blocks		24 VDC ±5%
Rated current between positive and negative terminal blocks		24 VDC: 12.3 mA × number of ON points
Cable length	To controller	5 m max. (reference value for AWG28)
	To I/O devices	Dependent on load
Ambient operating temperature		0 to 55°C (with no icing or condensation)
Ambient operating humidity		35% to 85%
LED color		Orange
Coil surge absorber		Diode (400 V, 300 mA)
Weight		Approx. 300 g

Note: The above values are initial values.

\*1. Measurement condition: 1 A at 5 VDC.

\*2. Ambient temperature: 23°C

### SSR Outputs

Item	Model	AC	DC
		G7VC-OA16	G7VC-OD16
Must operate time		1 ms max.	
Release time		1/2 cycles + 1 ms max.	1 ms max.
Output ON voltage drop		1.6 V (RMS) max.	1.5 V min.
Current leakage when the relay is open		2 mA max.	0.1 mA max. (at 26 VDC)
Insulation resistance		100 MΩ min. (at 500 VDC)	
Dielectric strength	Between coil and contact	2,000 VAC, 50/60 Hz for 1 minute	
	Between paired connectors	250 VAC, 50/60 Hz for 1 minute	
Vibration resistance		10 to 55 Hz with 0.5-mm single amplitude (1.0-mm double amplitude)	
Shock resistance		200 m/s <sup>2</sup>	
Noise immunity		Noise level: 1.2 kV; pulse width: 100 ns to 1 μs (excluding the primary side)	
Rated voltage between positive and negative terminal blocks		24 VDC ±5%	
Rated current between positive and negative terminal blocks		12.6 mA × number of ON points	15.4 mA × number of ON points
Cable length	To controller	5 m max. (reference value for AWG28)	
	To I/O devices	Dependent on load	
Ambient operating temperature		0 to 55°C (with no icing or condensation)	
Ambient operating humidity		35% to 85%	
LED color		Orange	
Coil surge absorber		Diode (400 V, 300 mA)	
Weight		Approx. 300 g	

Note: The above values are initial values.

# Internal Circuits

## G7VC-OC16 (NPN output/+ common)

**Note:** A controller with an NPN transistor, - common output can be connected to the G7VC-OC16.

**Connector Pin Configuration  
Top View**

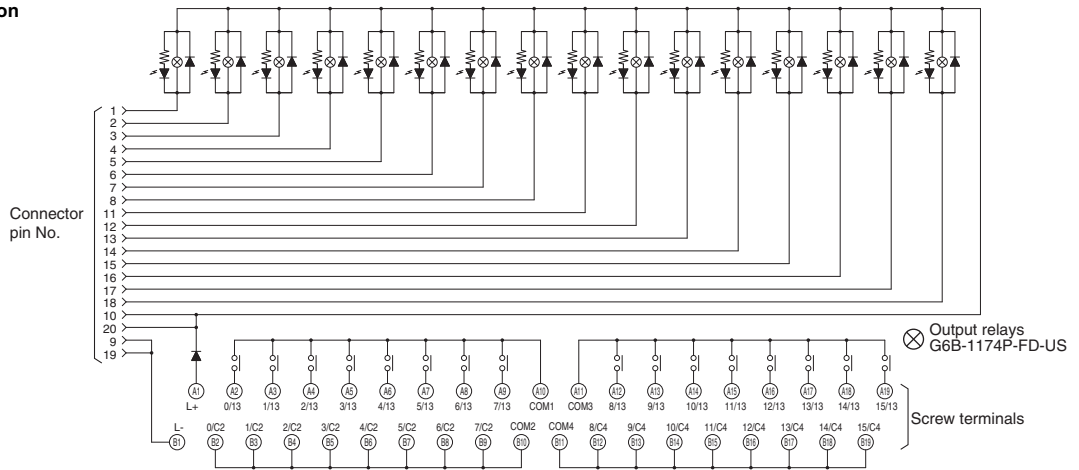
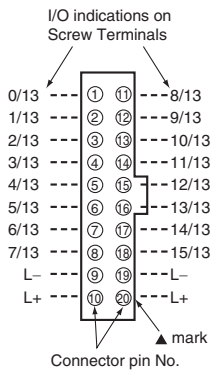

## G7VC-OC16-1 (PNP output/- common)

**Note:** A controller with a PNP transistor, + common output can be connected to the G7VC-OC16-1.

**Connector Pin Configuration  
Top View**

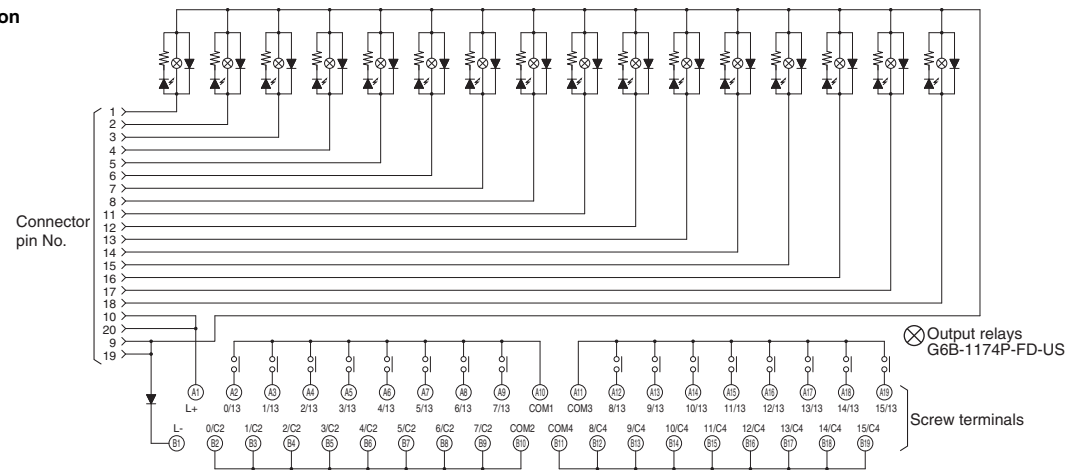
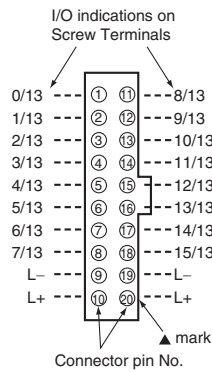

## G7VC-OA16

**Connector Pin Configuration  
Top View**

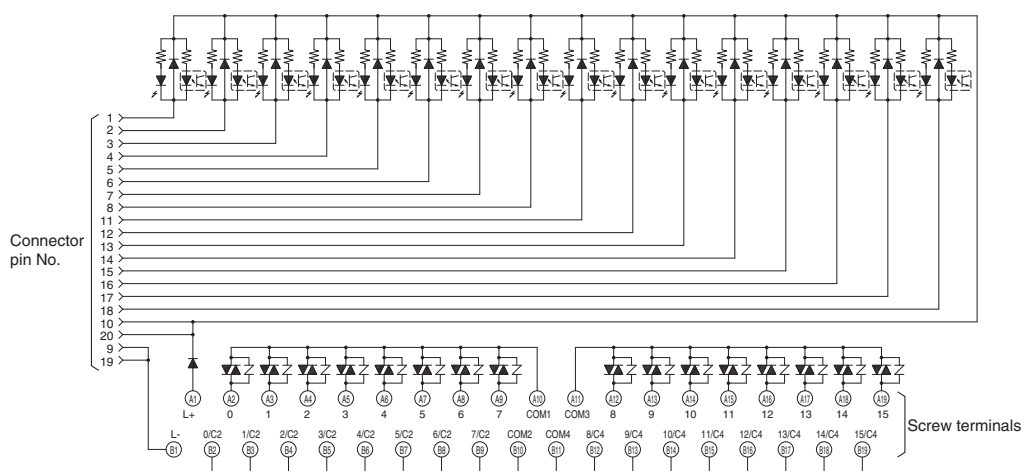
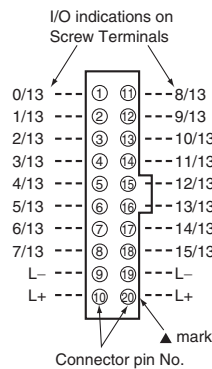

**Note:** Pin numbers are indicated for convenience. The ▲ mark can be used to determine orientation.

**G7VC-OD16**

**Connector Pin Configuration  
Top View**

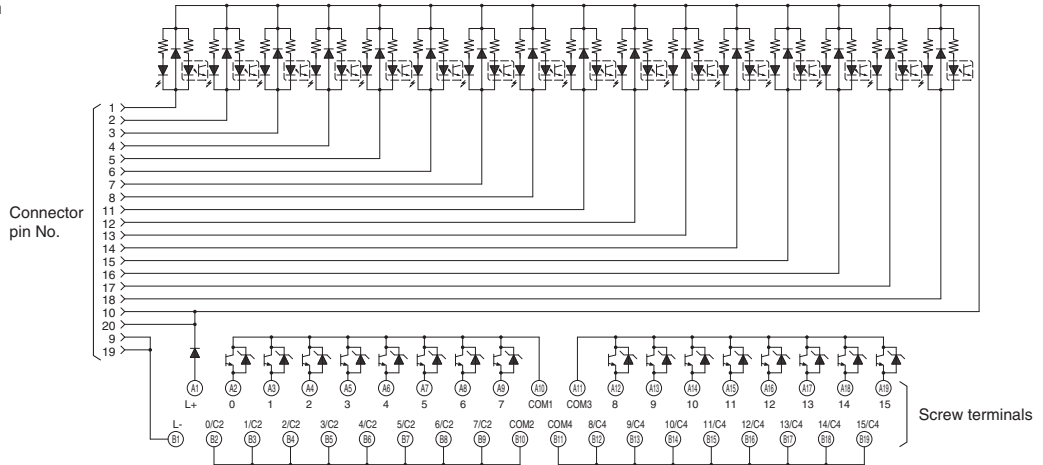
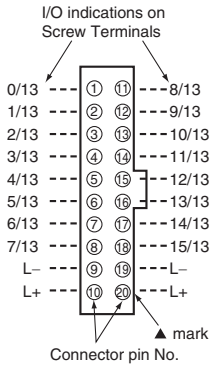

**Note:** Pin numbers are indicated for convenience. The ▲ mark can be used to determine orientation.

**Dimensions**

(Unit: mm)

**Relay Terminals**

- G7VC-OC16(-1)
- G7VC-OA16
- G7VC-OD16

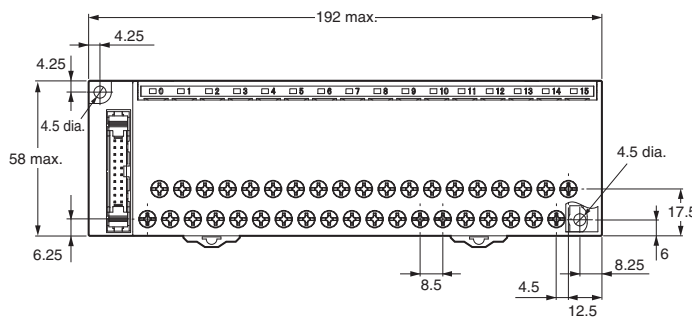
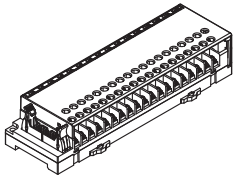

**G7VC-OC16(-1)**

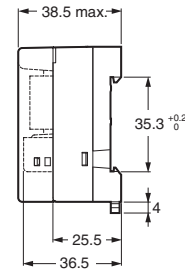

**G7VC-OA16  
G7VC-OD16**

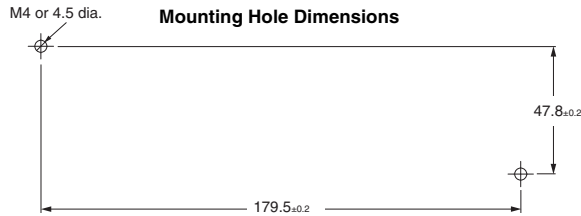
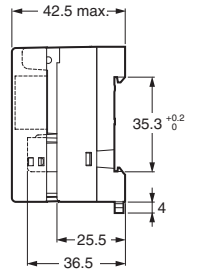

**Accessories (Order Separately)**

**Short bar**

**G78-V02**

For 16-point common connection.  
Max. current flow: 10 A

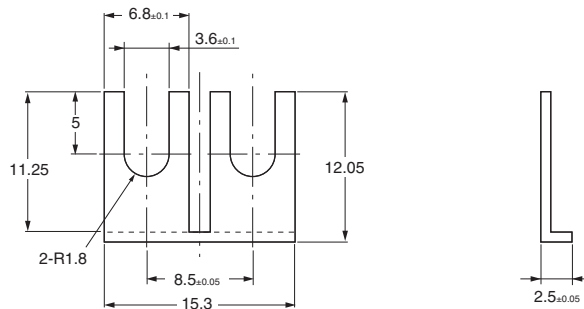

# Terminal Arrangement/Terminal Connection Example

G7VC-OC16(-1)

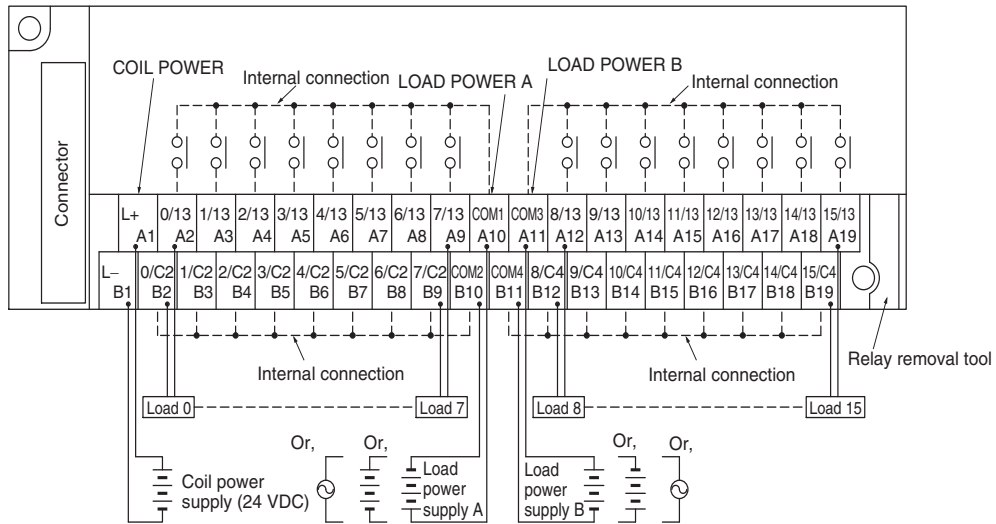

G7VC-OA16

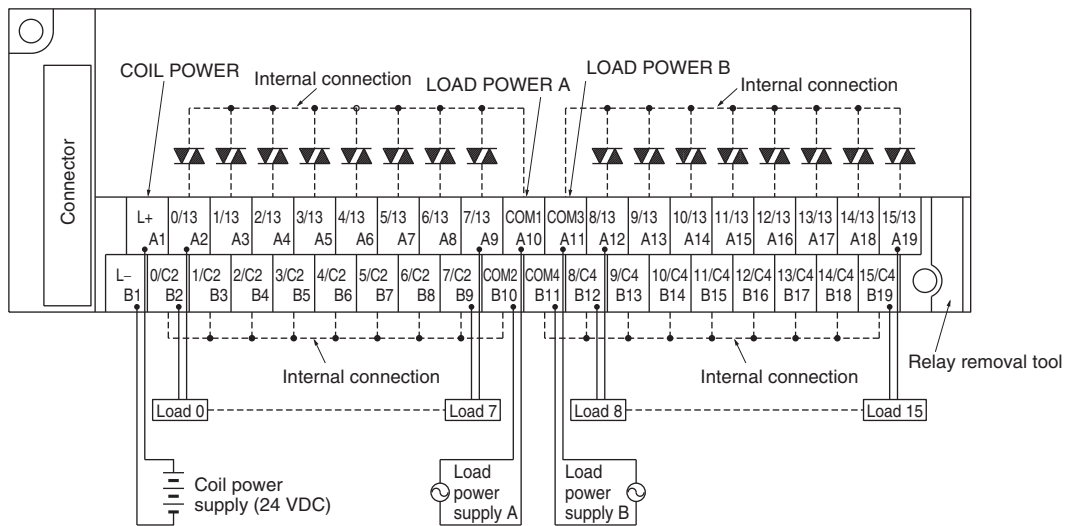

G7VC-OD16

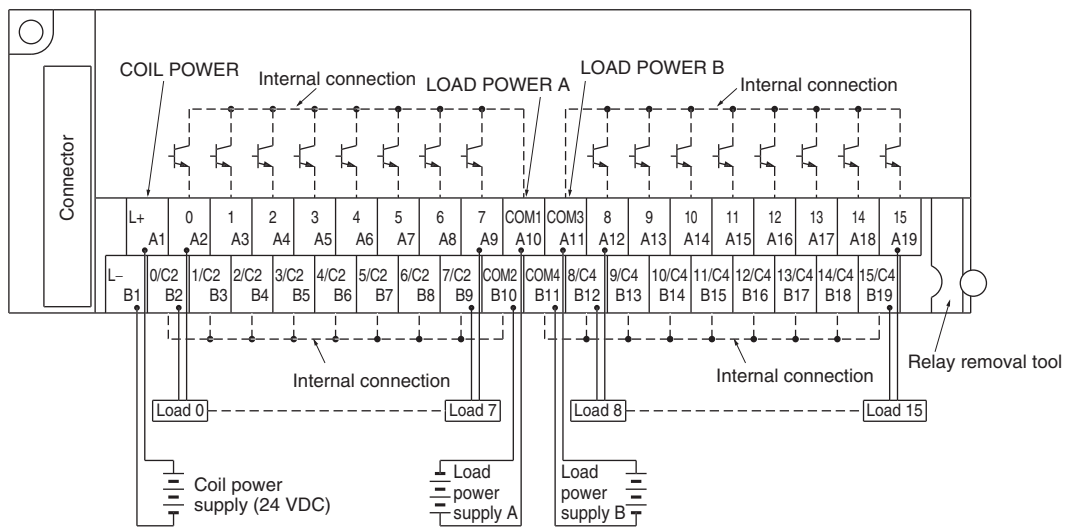

- Note:**
1. ----: Internal connections.
  2. Connect the power supply to drive the SSRs between A1 (L+) and B1 (L-). A1 (L+) is the positive terminal and B1 (L-) is the negative terminal.
  3. On the contact side, there are 2 commons with 8 points each. To use a 16-point common terminal, connect A10 (COM1) to A11 (COM3) and connect B10 (COM2) to B11 (COM4). (Optional short bar Type G78-V02 is available.)
  4. The following pairs of terminals are connected internally: B2 (0/C2) to B10 (COM2), and B11 (COM4) to B19 (15/C4).

## Safety Precautions

Be sure to read the *Common Precautions for I/O Relay Terminal* in the website at the following URL: <http://www.ia.omron.com/>.

### Warning Indications

Precautions for Correct Use	Supplementary comments on what to do or avoid doing, to prevent failure to operate, malfunction or undesirable effects on product performance.
-----------------------------	--

### Precautions for Correct Use

- This Relay Terminal is for outputs only.
- G6B-1174P-FD-US DC24V Relays are mounted as a standard feature on the G7VC.
- To replace the Relays, use the yellow relay removal tool provided on the right side of the screw terminals.

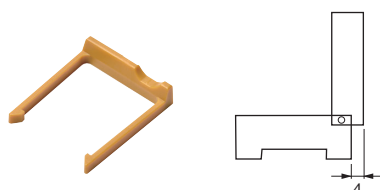

- When the cover is opened, it will extend 4 mm past the exterior of the Relay Terminal. Allow sufficient room to open the cover when you install the Relay Terminal.
- Contact output terminals are connected in the unit of eight COMs. Supply the power to A10 (COM1) and B10 (COM2) for the relays No. 0 to No. 7. B10 (COM2) and B2 thru B9 are connected internally. Similarly, supply the power to A11 (COM3) and B11 (COM4). B11 (COM4) and B12 thru B19 are connected internally. In the case of using the product with 16 COMs, connect A10 (COM1) to A11 (COM3) and B10 (COM2) to B11 (COM4), respectively. For short-circuit, the optional short bar Type G78-V02 is available. However, use it at the current less than 10 A for unit (16 COMs), less than 8 A for 8 COMs and less than 2 A for a COM.
- Avoid connecting and disconnecting the connectors while the power is ON. Otherwise misoperation may be caused.
- It is dangerous to mount or remove a Relay while power is being supplied.
- Opening the Front Cover (Rotating)  
Use both hands to lift up on the edges (A) at the bottom of the cover and rotate the cover.

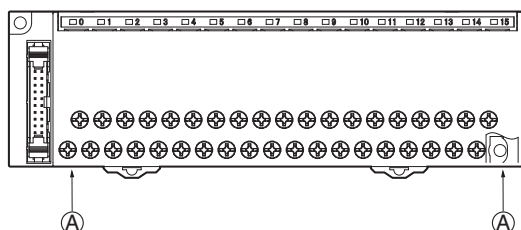

## Terms and Conditions Agreement

### Read and understand this catalog.

Please read and understand this catalog before purchasing the products. Please consult your OMRON representative if you have any questions or comments.

### Warranties.

(a) Exclusive Warranty. Omron's exclusive warranty is that the Products will be free from defects in materials and workmanship for a period of twelve months from the date of sale by Omron (or such other period expressed in writing by Omron). Omron disclaims all other warranties, express or implied.

(b) Limitations. OMRON MAKES NO WARRANTY OR REPRESENTATION, EXPRESS OR IMPLIED, ABOUT NON-INFRINGEMENT, MERCHANTABILITY OR FITNESS FOR A PARTICULAR PURPOSE OF THE PRODUCTS. BUYER ACKNOWLEDGES THAT IT ALONE HAS DETERMINED THAT THE PRODUCTS WILL SUITABLY MEET THE REQUIREMENTS OF THEIR INTENDED USE.

Omron further disclaims all warranties and responsibility of any type for claims or expenses based on infringement by the Products or otherwise of any intellectual property right. (c) Buyer Remedy. Omron's sole obligation hereunder shall be, at Omron's election, to (i) replace (in the form originally shipped with Buyer responsible for labor charges for removal or replacement thereof) the non-complying Product, (ii) repair the non-complying Product, or (iii) repay or credit Buyer an amount equal to the purchase price of the non-complying Product; provided that in no event shall Omron be responsible for warranty, repair, indemnity or any other claims or expenses regarding the Products unless Omron's analysis confirms that the Products were properly handled, stored, installed and maintained and not subject to contamination, abuse, misuse or inappropriate modification. Return of any Products by Buyer must be approved in writing by Omron before shipment. Omron Companies shall not be liable for the suitability or unsuitability or the results from the use of Products in combination with any electrical or electronic components, circuits, system assemblies or any other materials or substances or environments. Any advice, recommendations or information given orally or in writing, are not to be construed as an amendment or addition to the above warranty.

See <http://www.omron.com/global/> or contact your Omron representative for published information.

### Limitation on Liability; Etc.

OMRON COMPANIES SHALL NOT BE LIABLE FOR SPECIAL, INDIRECT, INCIDENTAL, OR CONSEQUENTIAL DAMAGES, LOSS OF PROFITS OR PRODUCTION OR COMMERCIAL LOSS IN ANY WAY CONNECTED WITH THE PRODUCTS, WHETHER SUCH CLAIM IS BASED IN CONTRACT, WARRANTY, NEGLIGENCE OR STRICT LIABILITY.

Further, in no event shall liability of Omron Companies exceed the individual price of the Product on which liability is asserted.

### Suitability of Use.

Omron Companies shall not be responsible for conformity with any standards, codes or regulations which apply to the combination of the Product in the Buyer's application or use of the Product. At Buyer's request, Omron will provide applicable third party certification documents identifying ratings and limitations of use which apply to the Product. This information by itself is not sufficient for a complete determination of the suitability of the Product in combination with the end product, machine, system, or other application or use. Buyer shall be solely responsible for determining appropriateness of the particular Product with respect to Buyer's application, product or system. Buyer shall take application responsibility in all cases.

NEVER USE THE PRODUCT FOR AN APPLICATION INVOLVING SERIOUS RISK TO LIFE OR PROPERTY OR IN LARGE QUANTITIES WITHOUT ENSURING THAT THE SYSTEM AS A WHOLE HAS BEEN DESIGNED TO ADDRESS THE RISKS, AND THAT THE OMRON PRODUCT(S) IS PROPERLY RATED AND INSTALLED FOR THE INTENDED USE WITHIN THE OVERALL EQUIPMENT OR SYSTEM.

### Programmable Products.

Omron Companies shall not be responsible for the user's programming of a programmable Product, or any consequence thereof.

### Performance Data.

Data presented in Omron Company websites, catalogs and other materials is provided as a guide for the user in determining suitability and does not constitute a warranty. It may represent the result of Omron's test conditions, and the user must correlate it to actual application requirements. Actual performance is subject to the Omron's Warranty and Limitations of Liability.

### Change in Specifications.

Product specifications and accessories may be changed at any time based on improvements and other reasons. It is our practice to change part numbers when published ratings or features are changed, or when significant construction changes are made. However, some specifications of the Product may be changed without any notice. When in doubt, special part numbers may be assigned to fix or establish key specifications for your application. Please consult with your Omron's representative at any time to confirm actual specifications of purchased Product.

### Errors and Omissions.

Information presented by Omron Companies has been checked and is believed to be accurate; however, no responsibility is assumed for clerical, typographical or proofreading errors or omissions.

2017.1

In the interest of product improvement, specifications are subject to change without notice.

**OMRON Corporation**  
Industrial Automation Company

<http://www.ia.omron.com/>

(c)Copyright OMRON Corporation 2017 All Right Reserved.