

Rotary Encoder(Hollow Shaft/Blind Shaft)

HE40H/40HB

INSTRUCTION MANUAL

Thank you for purchasing HANYOUNG product.
Please check whether the product is the exactly same as you ordered.
Before using the product, please read this instruction manual carefully.
Please keep this manual where you can view at any time



HANYOUNGNEX CO.,LTD

1381-3, Juan-Dong, Nam-Gu Incheon, Korea, TEL:(82-32)876-4697 FAX:(82-32)876-4696 http://www.hynux.net

HEAD OFFICE

Safety information

⚠ DANGER	DANGER indicates an imminently hazardous situation which, if not avoided, will result in death or serious injury
⚠ WARNING	WARNING indicates a potentially hazardous situation which, if not avoided, could result in death or serious injury
⚠ CAUTION	CAUTION indicates a potentially hazardous situation which, if not avoided, may result in minor or moderate injury

⚠ Warning

• Since this product is not designed as a safely used device the user must install double safety equipment when this product is used for equipment with possible fatal accident or large property damage.

⚠ Caution

- Please check for correct model type and specification.
- Please check for any damage or abnormality that may occurred during shipment.
- Rotary encoder is composed of very precision parts so impacting strong shock to the product may damage the function therefore, please handle with care.
- The shield wire of rotary encoder is not connected to the CASE
- If the device is touched or contacted by water then short-circuit and fire may occur so please inspect the device with care
- We recommend the continuous inspection and repair in order to use it safely for a long period of time.
- Not following this instruction manual may result in personal injury and property damage.

■ About Mega Test

- Although it has an internal voltage 800 V d.c in between the CASE and electric circuit, internal electric circuit may get damaged or destroyed if users use wrong method when applying the voltage. Therefore, please do not perform the mega test.

■ About Installation

- When installing, do not apply strong force or twist the rotational axis of encoder.
- The life expectancy of rotary encoder varies depending on the using condition or environment so please be cautious
- Do not disassemble, manufacture, upgrade and repair the product by yourself.
- Please turn OFF the product and disassemble the product. Not doing so will break down the product and cause malfunction to occur.
- Rotary encoder is composed of very precision parts so impacting strong shock to the product may damage the function therefore, please handle with care.
- When installing the rotational axis of rotary to the device, please use the Coupling and when installing the Coupling to axis, do not apply strong force.
- When mounting the product, as the eccentricity and angle deviation become larger, the force applied to the shaft will become large too and result may damage the product or shorten the life expectancy.

■ About Environment.

- Please avoid using this product at following environment. Doing so may break down the product or cause malfunction to occur.
- Place where the internal parts or structure become damaged by the strong vibration and shock
 - Place near to the machine which generates the strong electromagnetism or electrical noise
 - Place that does not fall into the given specification especially for ambient temperature and humidity.

■ About wiring

- Please separate the input signal wire and output signal wire from each other but when separating them from each other is impossible, please use the shield wire for input wire.
- When there are too much noises generating from the power, we recommend using the insulation Trans and noise filter.
- Please check the polarity of terminal before wiring.
- Please make the wiring length as short as possible
- Wiring the rotary encoder wire and power wire to each other may cause malfunction to occur so please be cautious.
- False wiring of rotary encoder may break down the internal circuit so please be cautious
- If type for applying power is SMPS, surge may occur so please connect noise filter (surge observer) to the power terminal and doing so will solve the problem that corresponds to the surge. Also, in order to minimize the effect causing by noise and etc, please make the wiring as short as possible.
- When extending or drawing out the cable, please use the Twist Pair wire. Shield wire must be connected to the F.G terminal!

■ About the vibration

- If strong vibration or shock is carried out through the rotary encoder, incorrect pulse may be generated and this may end up as malfunction of system so please be cautious about the installation place, mounting place and etc.
- As there are much of pulse generation per 1 rotation, the slit gap of rotational slit gets narrower so it may be influenced by vibration easily and the vibration applied during spinning or when it is stopped, it will be carried through out this device so may generate the wrong pulse so please be cautious.
- When inserting the coupling to Shaft, do not apply shock by using the hammer and etc

■ For noise prevention

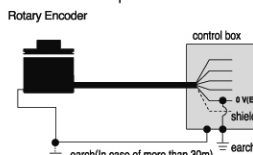

Distance from control box	Wiring of Rotary Encoder
30 m Max.	As for Rotary Encoder Case, connect on the control board case by 3~5.5 m ² electric wire. For the 0 V terminal, connect on the control board case with identical type of electrical wire and earth it.
30 m Min.	Perform as indicated above, and earth the Rotary Encoder.

※ The caution on the safety stated above, must be kept, otherwise malfunction can be induced.

Suffix code

Model	Code	Information	
HE40	□-□□□□□□	∅ 40 mm rotary encoder. Incremental	
Dimension	H	6	Hollow Shaft Inner diameter : ∅ 6 mm
		8	Inner diameter : ∅ 8 mm
		10	Inner diameter : ∅ 10 mm
		12	Inner diameter : ∅ 12 mm
	HB	6	Blind shaft Inner diameter : ∅ 6 mm
		8	Inner diameter : ∅ 8 mm
		10	Inner diameter : ∅ 10 mm
		12	Inner diameter : ∅ 12 mm
Number of pulse	*	Refer to the pulse code chart(resolving power)	
Output signal	2	A, B phase output	
	3	A, B, Z phase output	
	3C	A, B, Z̄ phase output	
	4	A, Ā, B, B̄ phase output	
	6	A, Ā, B, B̄, Z, Z̄ phase output	
	Output circuit	N	12
24			NPN voltage output (12 - 24 V d.c)
O		12	NPN open collector output (5 - 12 V d.c)
		24	NPN open collector output (12 - 24 V d.c)
T		12	Totem pole output (5 - 12 V d.c)
		24	Totem pole output (12 - 24 V d.c)
L		5	Line Driver output (5 V d.c)
		12	Line Driver output (12 V d.c)- Apply only for HE40HB
	24	Line Driver output (24 V d.c)-Apply only for HE40HB	

Model	Number of pulse per 1 revolution
HE40H/40HB	*1, *2, *5, 10, *12, 15, 20, 25, 30, 40, 45, 50, 60, 75, 100, 120, 125, 150, 192, 200, 240, 250, 256, 300, 360, 400, 500, 512, 600, 800, 1000, 1024, 1200, 1500, 1800, 2000, 2048, 2500 (38 Types)

※ A and B phase only can be generated with 「*」mark (Line drive output : A, Ā, B, B̄ phase)

※ Pulses other than pulses in the chart are order made product

Specification

Mode	HE40HB	HE40HB	HE40HB	HE40HB
	-□-□-□-□-□-□-□-□	-□-□-□-□-□-□-□-□	-□-□-□-□-□-□-□-□	-□-□-□-□-□-□-□-□
	HE40H	HE40H	HE40H	HE40H
	-□-□-□-□-□-□-□-□	-□-□-□-□-□-□-□-□	-□-□-□-□-□-□-□-□	-□-□-□-□-□-□-□-□
Output type	NPN Voltage output	NPN Open collector output	Totem Pole output	Line Drive output
Output signal	A, B, Z phase			A, B, Z̄, Ā, B̄, Z̄ phase
Phase difference on Output	Phase difference between A, B phase : T/4 ± T/8(Cycle of A phase = T)			
Max Response Frequency	300 kHz			
Power voltage	5 - 12 V d.c / 12 - 24 V d.c ± 5 %			5 V d.c ± 5 % 12/24 V d.c ± 5 % (Apply only for HE40HB)
Current Consumption	60 mA Max. (No-load)			
Connection method	Cable extended type			
Control output	Load voltage : 30 V Max. Load Current : 30 mA Max. Residual Voltage : 0.4 V Max.		For Low Load Current : 30 mA max. Remaining Voltage : 0.4 V max. For High Load Current : 10 mA max. Remaining Voltage : 2.5 V min. Power Voltage - 25 V min.	For Low Load Current : 20 mA max. Remaining Voltage : 0.4 V max. For High Load Current : 20 mA max. Remaining Voltage : 2.5 V min.
Response Time	1μs Max. (Cable length 1.5 m / sink= 30 mA)			1μs Max.(Cable length 1.5 m / sink= 30 mA)

Mechanical Specification	Starting Torque	0.02 N · m Max.
	Moment of inertia	4×10^{-6} kg · m ² Max
Permissible Shaft Loading	Radial : With in 30 N, Thrust : With in 20 N	
	Max. Permissible Revolution	5000 r/min
Insulation Resistance	Over 100 M Ω (Base on 500 V d.c mega between terminal and case)	
Dielectric strength	800 V a.c (Between terminal and case at 60Hz for 1 minute)	
Vibration Resistance	10 - 55Hz (Cycle for 1 minute), Double amplitude width: 1.5mm, Each X-Y-Z direction for 2 hours	
Shock Resistance	490 % ² Max.	
Ambient Temperature	-10 ~ 70 °C(Without condensation), Storage Temperatur : -25 ~ 85 °C	
Ambient Humidity	35 ~ 85 % R.H.	
Protection	Protection IP 50 (IEC Standard)	
Wire Specification	5 P, ϕ 5.0 mm, Length : 1.5 m, Shield cable(Option : 2 m, 8 m, 10 m) (Line Driver Type : 8P, ϕ 5.0 mm, Length : 1.5 m, Shield cable)	
Weight	170 g	
Accessory	Spring Bracket	

Dimension

[unit : mm]

■ ϕ 40 Hollow Built in Shaft

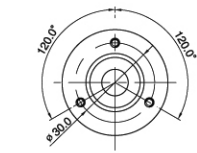

A	ϕ 6	ϕ 8	ϕ 10	ϕ 12
B	ϕ 19		ϕ 17	

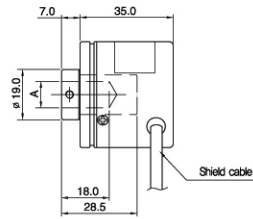

■ ϕ 40 Hollow Shaft

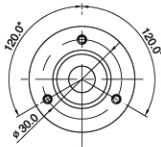

A	ϕ 6	ϕ 8	ϕ 10	ϕ 12
B	ϕ 19		ϕ 17	

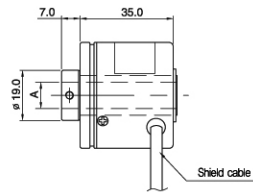

■ Accessory

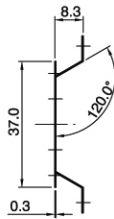
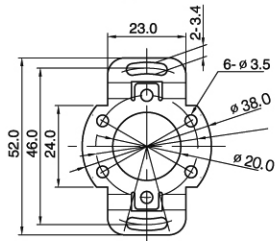

Wiring Diagram

■ Voltage output, Totem Pole output, Open collector output

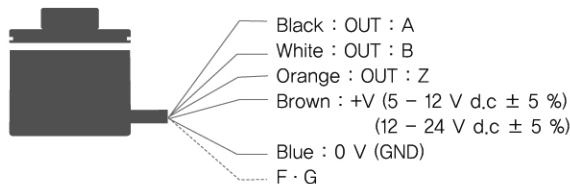

■ Line Driver Output

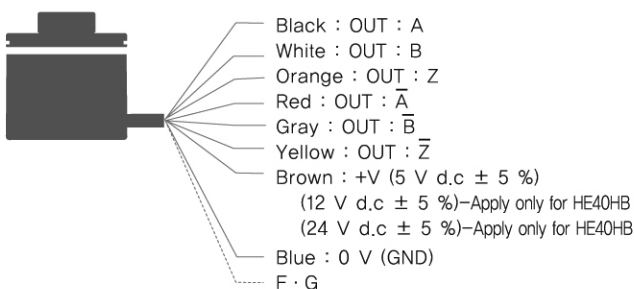

※ Please insulate unused lines

※ Metal case of encoder and Shield line must be ground connection.

※ Hollow Built-in Shaft : Same connection way as Hollow Shaft.

Control output circuit diagram

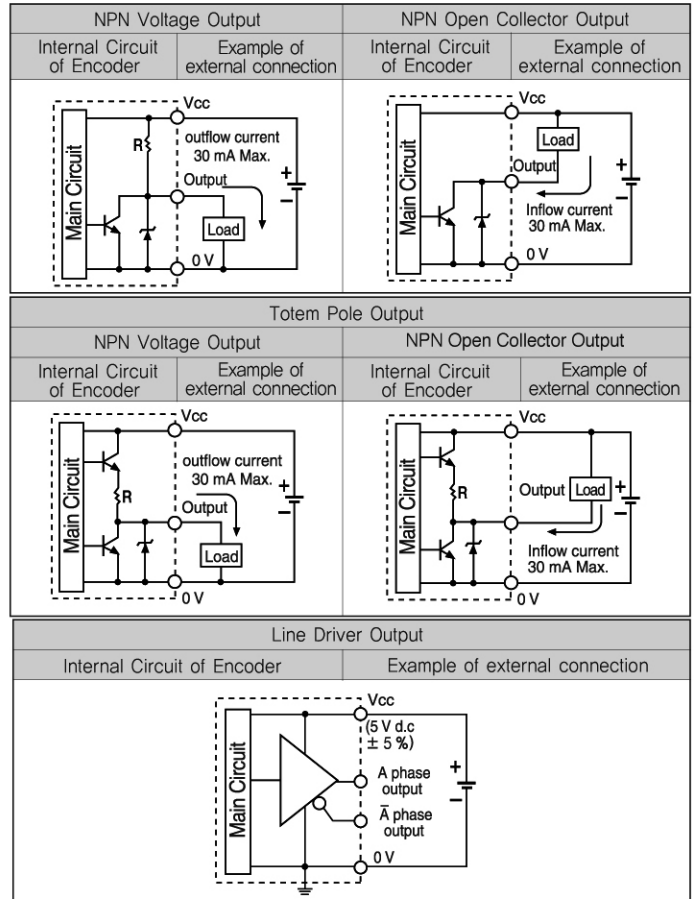

※ The output circuit of A, B, Z phase (Line drive output A, A-bar, B, B-bar, Z, Z-bar phase) is same.

Output wave

■ NPN Voltage output, NPN Open Collector Output, Totem Pole output

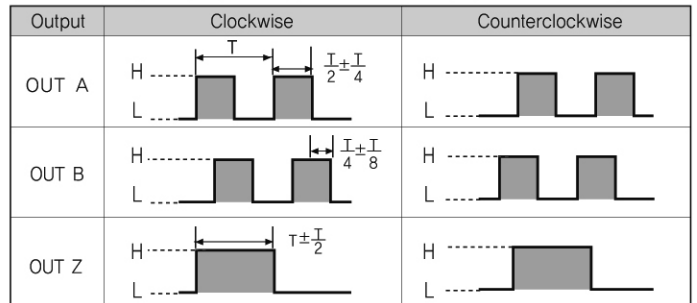

■ Line Driver Output

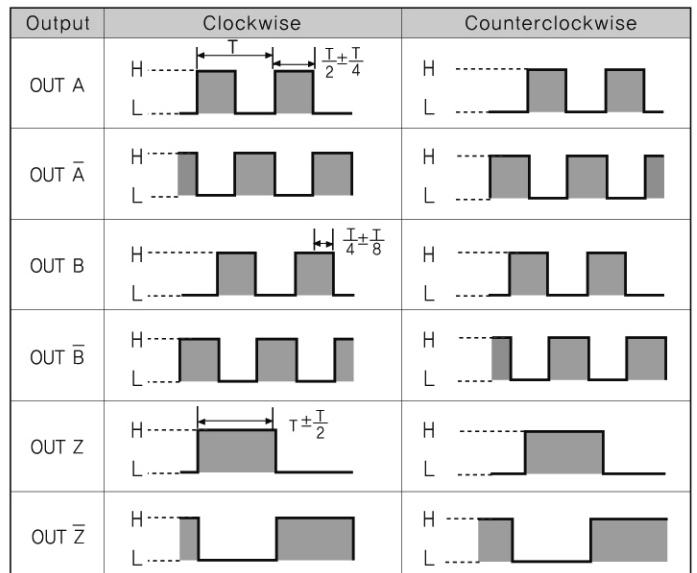

Clockwise (CW): When you are looking at the shaft of the product, it is turning in a clockwise direction.
Counterclockwise (CCW): When you are looking at the shaft of the product, it is turning in a counterclockwise.