

Fan Type Ionizer



Thinnest and Fastest

Thickness **40** mm Rapid static neutralization **0.5**^{*1} seconds



IZF21 Series

IZF31 Series

■ Extensive rapid static neutralization^{*1}

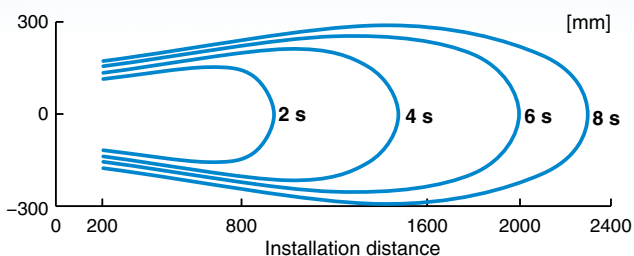

*1 When neutralizing static electricity from 1000 V to 100 V at a distance of 300 mm from the workpiece (front surface). When air flow of IZF31 is maximum.



IZF10/10R Series

■ Offset voltage (Ion balance): **±5 V**

Compact fan types ▶ Page 21

IZF Series



CAT.ES100-113C

Extensive Rapid Static Neutralization

Extensive static neutralization

IZF 21 IZF 31

►For the IZF21. For details about the IZF31, refer to page 10.
 ►Refer to page 4 for flow rate adjustment and the description below for angle adjustment of the adjustable louver.



At maximum flow rate

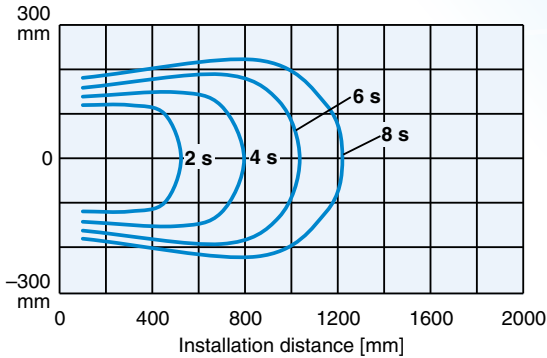

At maximum flow rate, with adjustable louver/widest angle

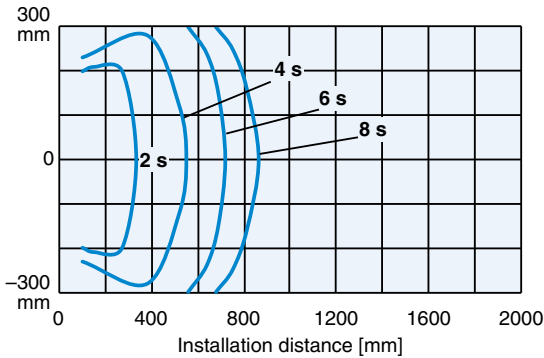

At maximum flow rate, with adjustable louver/narrowest angle

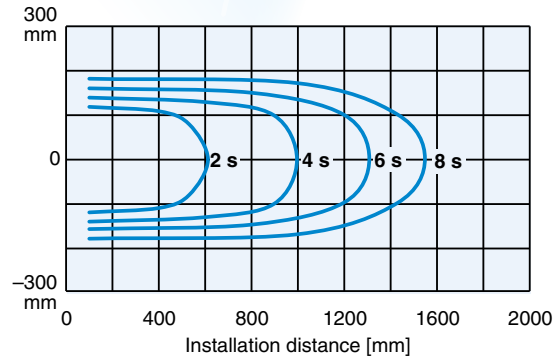

Extensive static neutralization area can be covered with adjustable louver.

IZF 21 IZF 31

Option p. 12

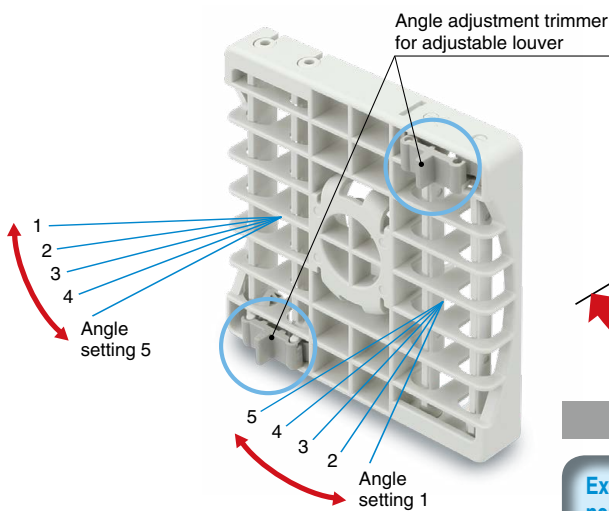

Adjustable in 5-stages from wide to narrow angle

90-degree rotation mounting available (Adjustable in a vertical direction)

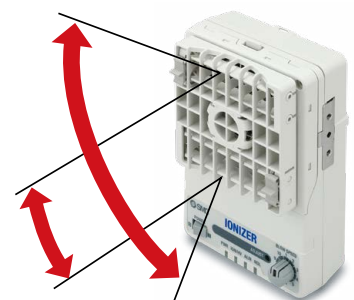
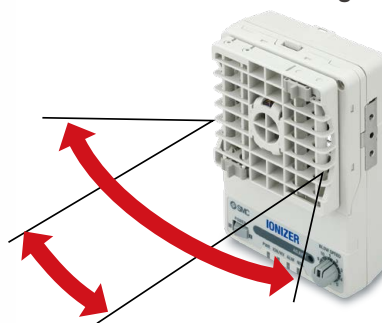

Application Examples

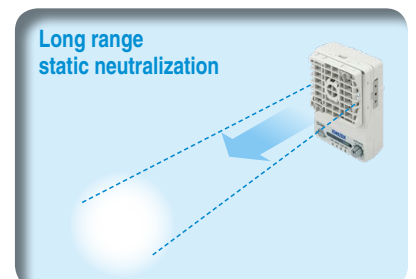
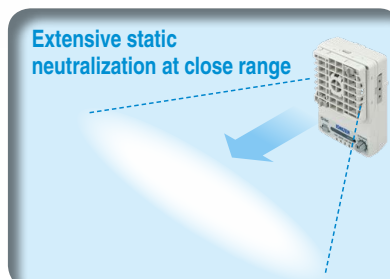

Rapid static neutralization



Installation distance and discharge time (Discharge time from 1000 V to 100 V)

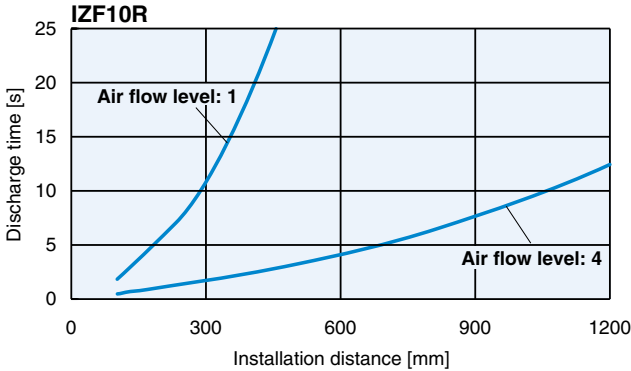
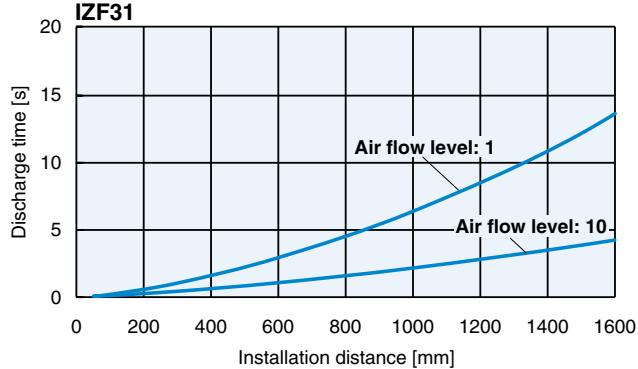
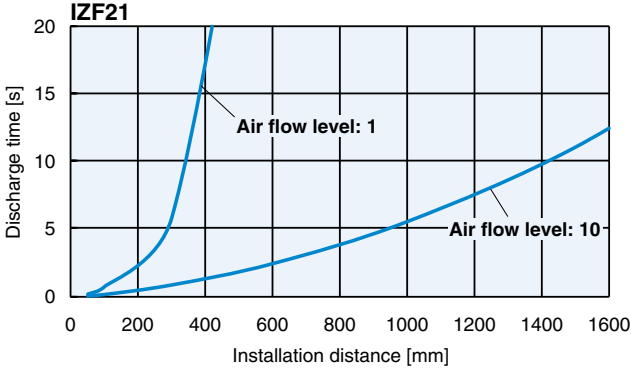

Stable Static Neutralization Performance, Easier Maintenance

Emitter life is almost doubled with averaging function.

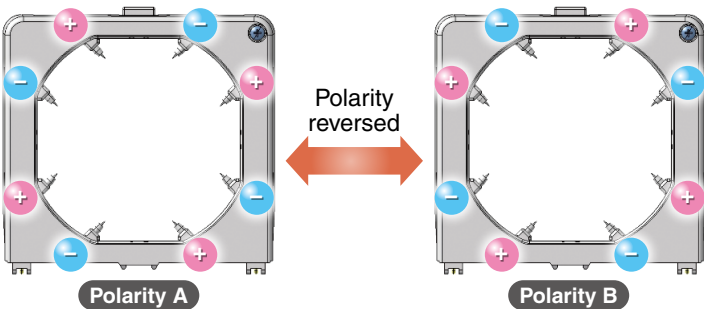

Averaging Function

The life of the emitters is almost doubled by switching the polarity of the applied high voltage every time the power is supplied hence averaging the wear level of the emitters.

* Compared with the IZF10.

Built-in sensor constantly monitors offset voltage.



Automatic balance adjustment function achieves stable offset voltage and reduces adjustment time.

Automatic adjustment
Prevents degradation in offset voltage that can occur when emitters become contaminated after prolonged ionizer operation.

Manual adjustment
Corrects changes to offset voltage due to the installation environment.

Constantly monitors offset voltage by use of a sensor. Prevents degradation in offset voltage that can occur when emitters become contaminated after prolonged ionizer operation. Balance adjustment trimmer can provide offset voltage adjustment suitable for the installation environment.

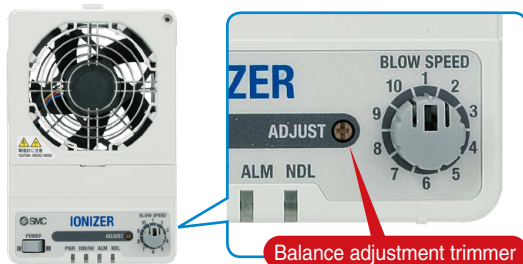

Stable Static Neutralization Performance, Easier Maintenance

Emitter contamination can be reduced by automatic cleaning function.

IZF 21 IZF 31 Option p. 12

Cleaning arms are installed inside the housing. Emitter cleaning is started by an external input signal or push-button operation.

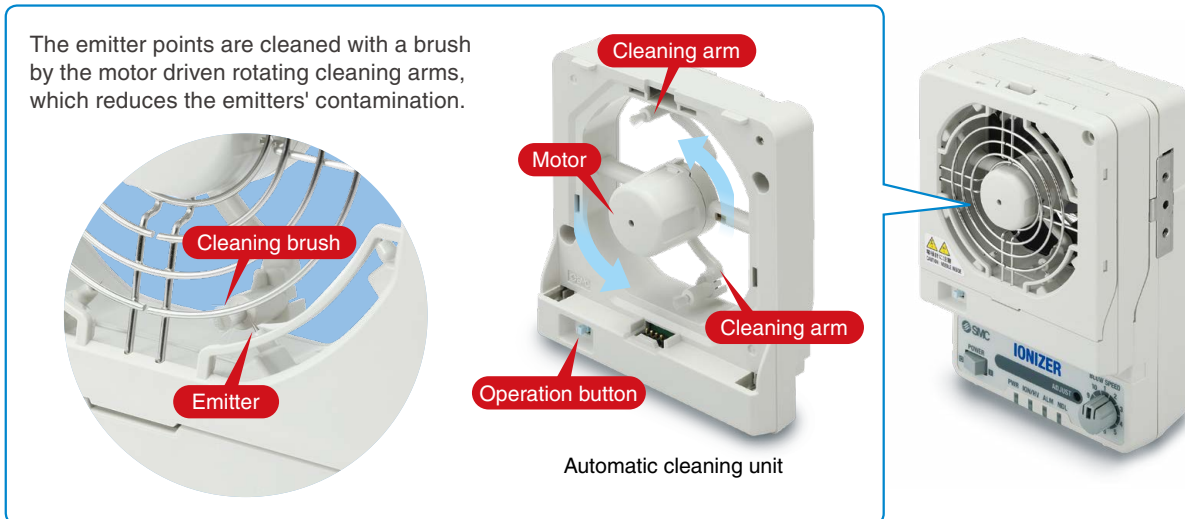

Contamination of the emitters can be detected.

IZF 10 IZF 10R IZF 21 IZF 31

Emitter contamination level is constantly monitored. When maintenance is required, the user is alerted by a signal output and the LED turning ON.

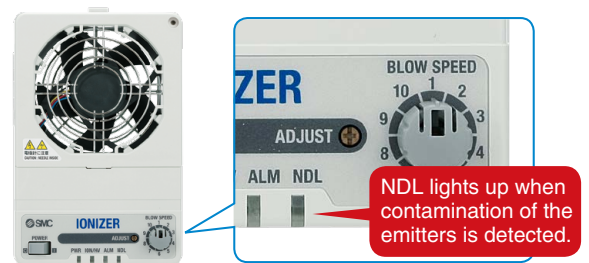

Emitter cartridge is easily replaceable. (No tools are required.)

IZF 21 IZF 31 p. 12

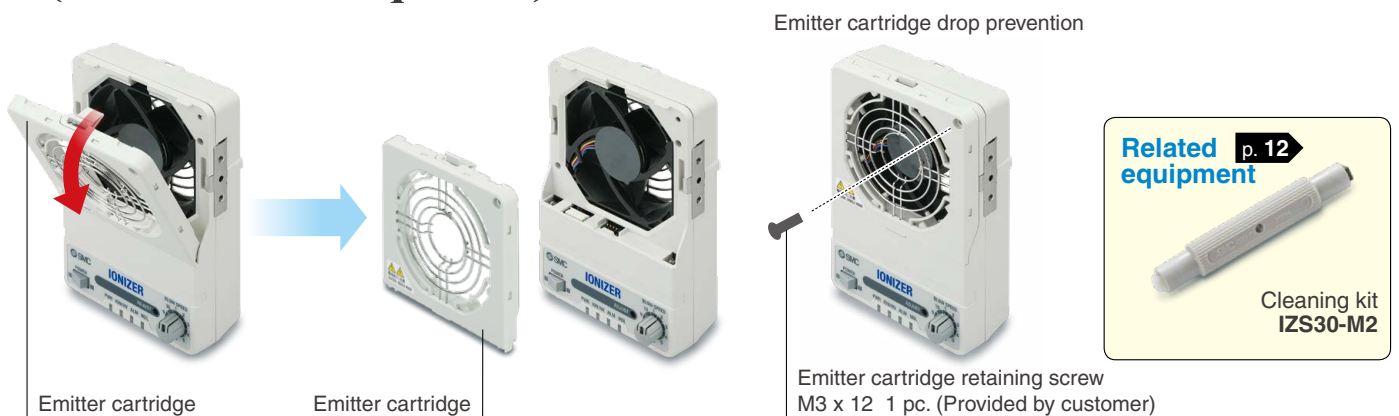

Flow Rate Adjustment Function

IZF 10R IZF 21 IZF 31

Flow rate is adjustable in 10 steps* using the flow rate adjustment dial. The flow rate adjustment dial is removable to prevent accidental changes of adjustment.

Flow Rate Adjustment Range [m³/min]

Model	Flow rate adjustment level									
	1	2	3	4	5	6	7	8	9	10
IZF10R	0.19	0.46	0.66	0.80	—	—	—	—	—	—
IZF21	0.4	0.5	0.6	0.7	0.8	0.9	1.1	1.4	1.7	1.8
IZF31	1.3	1.7	1.9	2.3	2.5	2.7	3.2	3.7	4.2	4.4

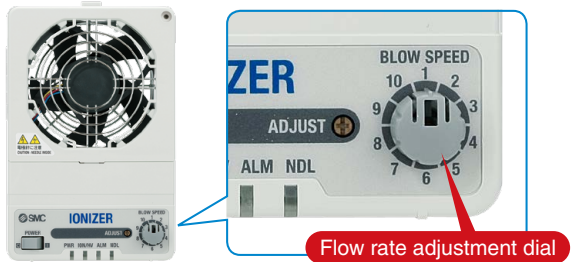

* For IZF21, 31

7 types of alarms are provided.

IZF 21 IZF 31

1 Power supply failure



2 Incorrect high voltage



3 Fan motor failure



4 CPU failure



5 Maintenance warning



6 Emitter cartridge mounting failure



7 Automatic cleaning failure

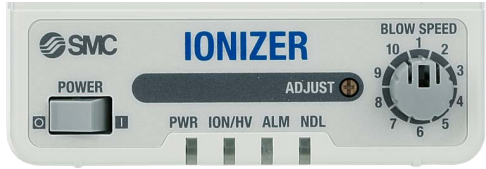

LED indicator can be checked from 2 directions!

IZF 21 IZF 31



LED Indicators	
PWR	Power supply indicator
ION/HV	Static neutralization operation/ Incorrect high voltage indicator
ALM	Error indicator
NDL	Maintenance indicator

Filter

IZF 21 IZF 31

Option p. 12

Prevents ingress of lint and foreign matter to the motor and possibility of short-circuit between emitters!

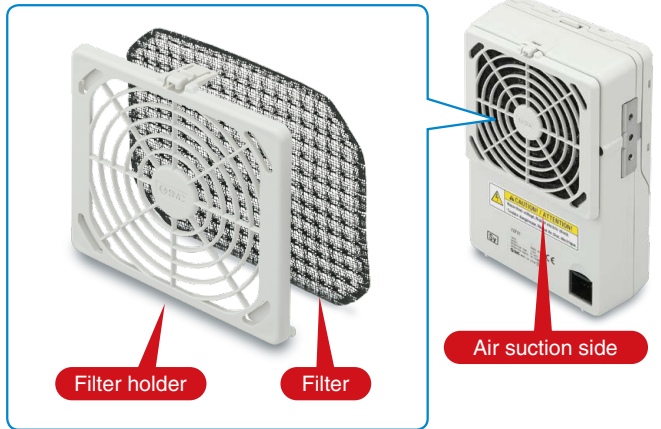

Models and Functions

		IZF21 p. 11	IZF31 p. 11	IZF10 p. 21	IZF10R p. 21
Size (Depth x Width x Height) [mm]		40 x 104 x 155	40 x 144 x 195	39 x 80 x 110	39 x 80 x 110
Maximum air flow [m ³ /min]		1.8	4.4	0.66 0.46 (L type)	0.80
Extensive static neutralization		●	●	—	—
High speed neutralization		●	●	●	●
Adjustable louver		●	●	—	—
Averaging function		●	●	—	—
Automatic balance adjustment function (With built-in sensor)		●	●	—	—
Automatic cleaning function		●	●	—	—
Emitter dirt detection		●	●	●	●
Easily replaceable (Emitter cartridge)		●	●	—	—
Flow rate adjustment function		●	●	—	●
Filter		●	●	—	—
Alarm	Power supply failure	●	●	●	●
	Incorrect high voltage	●	●	●	●
	Fan motor failure	●	●	—	—
	CPU failure	●	●	—	—
	Maintenance warning	●	●	● (LED indication only)	●
	Emitter cartridge mounting failure	●	●	—	—
	Automatic cleaning failure	●	●	—	—

Application Examples

For the static neutralization of conveyors

Static neutralization in a narrow space

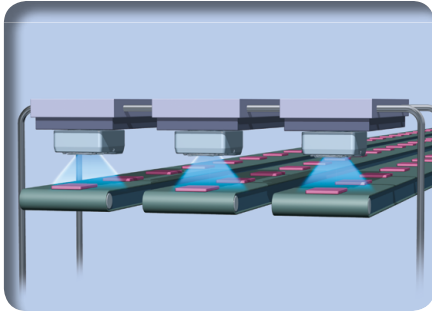

For the static neutralization of PET bottles

Trip-resistance during conveying/Prevents adhesion of dust.

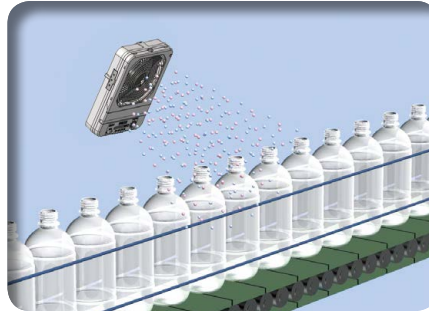

For the static neutralization of films

Prevents winding failure./Prevents adhesion of dust.

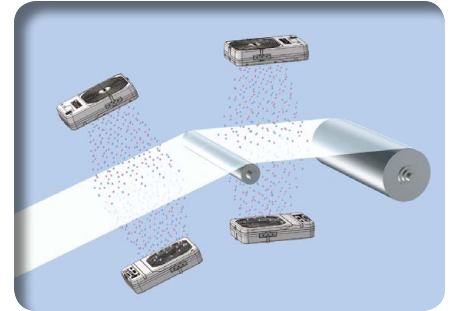

For the static neutralization of molded goods

Improves detachability of molded goods from a die.

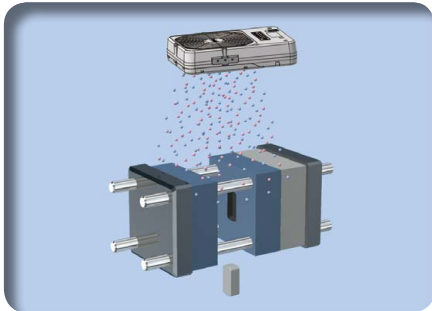

For the static neutralization of film-molded goods

Sticking and scattering prevention on a conveyor

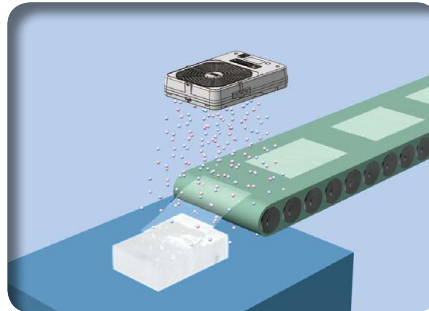

For the static neutralization of packaging materials made from polystyrene foam

Darkening due to dust adhesion prevented

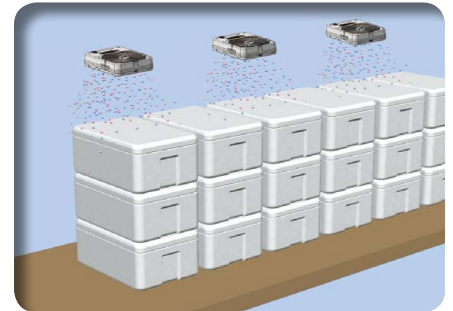

For the static neutralization of packing films

Prevents the filled substance from adhering to the packing film and reduces packing mistakes.

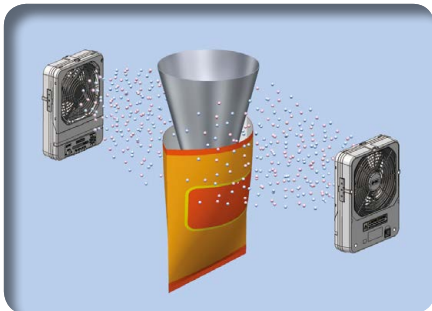

For the static neutralization of parts feeders

Prevents the clogging of parts feeders.

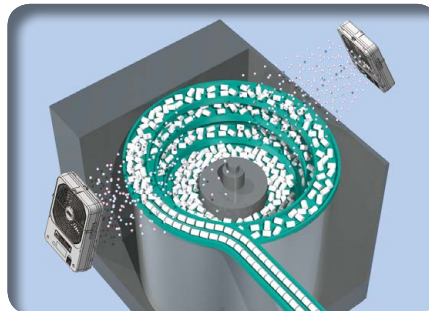

For the static neutralization of electric substrates

Prevents failures due to ESD and adhesion of dust.

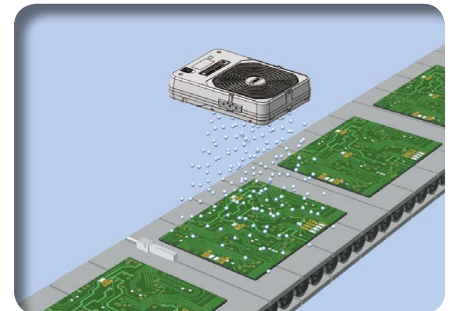

Compact fan type with simple functions IZF10/10R Series Page 21

- Compact design (Depth x Width x Height): 39 mm x 80 mm x 110 mm
- Weight: 280 g (IZF10), 260 g (IZF10R)
- 2 types of fans available (IZF10)
 - ◎Rapid static neutralizing fan: Discharge time (Static neutralization time)*1
1.5 s (When neutralizing static electricity from 1000 V to 100 V at a distance of 300 mm from the workpiece (front surface))
 - ◎Low-noise fan: 48 dB(A) (Measured at a distance of 300 mm from the workpiece),
Rapid static neutralizing fan: 57 dB(A)
- Offset voltage (Ion balance)*1: ±13 V
- With alarms for
Incorrect high voltage, Maintenance warning
- With flow rate adjustment function (IZF10R)

*1 Based on ANSI/ESD-STM3.1-2015 standards



CONTENTS

IZF21/31 Series IZF10/IZF10R Series



With Flow Rate Adjustment Function

● Fan Type Ionizer IZF21/31 Series

Technical Data/Static Neutralization Performance

- ① Installation Distance and Discharge Time p. 9
- ② Static Neutralization Range p. 10
- How to Order p. 11
- Accessories p. 12
- Accessories Sold Separately p. 12
- Specifications p. 13
- Functions and Indications p. 13
- Alarm p. 13
- Wiring p. 14
- Wiring Circuit p. 14
- Operation Chart p. 15
- Dimensions p. 16

● Fan Type Ionizer IZF10/IZF10R Series

Technical Data/Static Neutralization Performance

- ① Installation Distance and Discharge Time p. 20
- ② Static Neutralization Range p. 20
- How to Order p. 21
- Accessories p. 22
- Accessories Sold Separately p. 22
- Specifications p. 23
- Functions and Indications p. 23
- Alarm p. 23
- Wiring p. 24
- Wiring Circuit p. 24
- Operation Chart p. 26
- Dimensions p. 27

- Specific Product Precautions p. 29

IZF21/31 Series Technical Data



Static Neutralization Performance

* Static neutralization characteristics are based on data using a charged plate (dimensions: 150 mm x 150 mm, capacitance: 20 pF) as defined in the U.S. ANSI standards (ANSI/ESD STM3.1-2015). Use this data only as a guideline for model selection because the values vary depending on the material and/or size of the subject.

① Installation Distance and Discharge Time (Discharge Time from 1000 V to 100 V)

IZF21

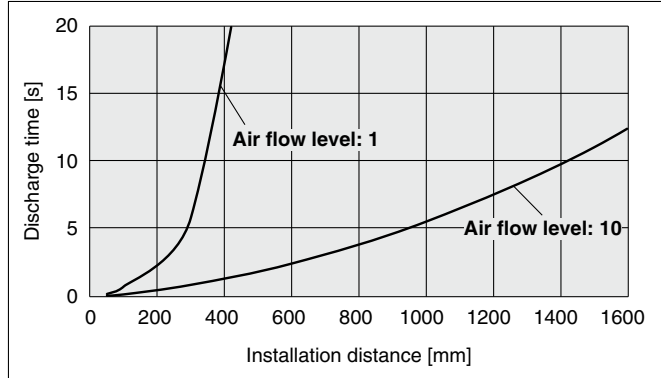

IZF31

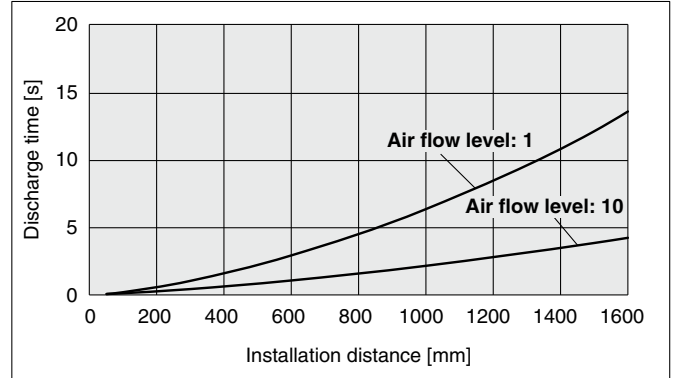

IZF21-S (With automatic cleaning unit)

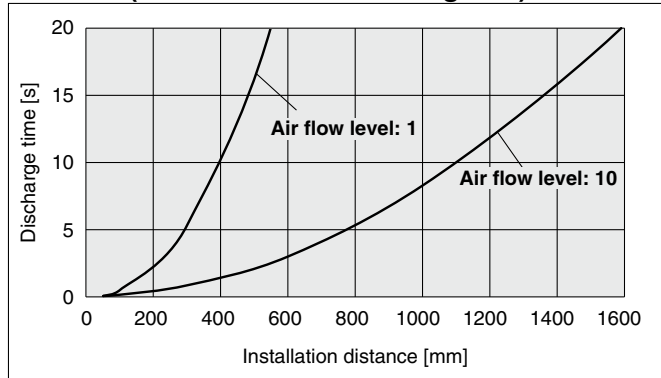

IZF31-S (With automatic cleaning unit)

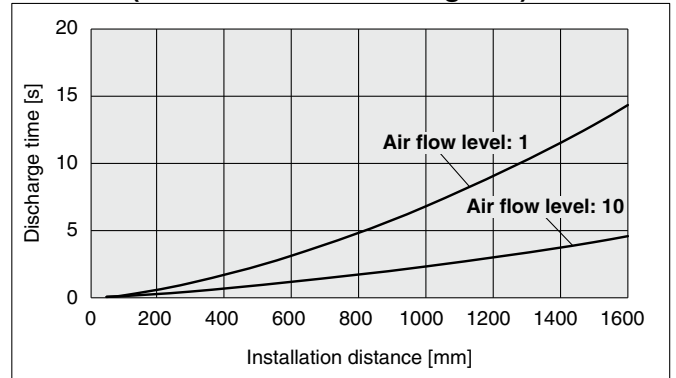

IZF21-U (With filter)

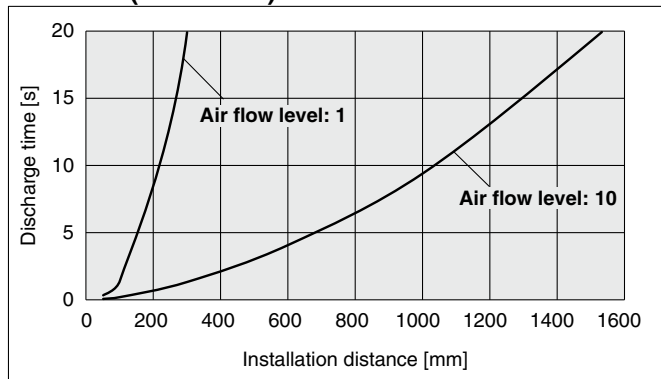

IZF31-U (With filter)

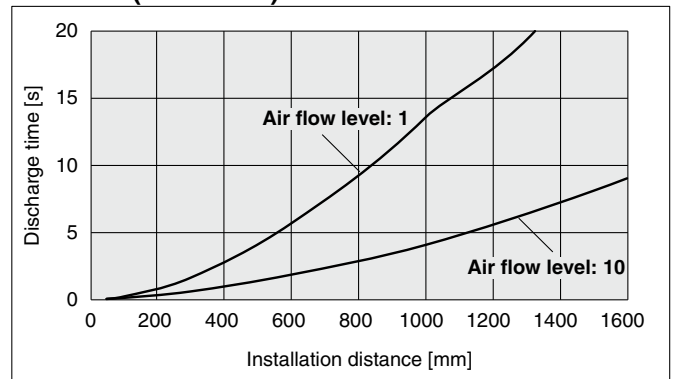

* Static neutralization characteristics are based on data using a charged plate (dimensions: 150 mm x 150 mm, capacitance: 20 pF) as defined in the U.S. ANSI standards (ANSI/ESD STM3.1-2015). Use this data only as a guideline for model selection because the values vary depending on the material and/or size of the subject.

Static Neutralization Performance

② Static Neutralization Range

IZF21 (Air flow level: 10)

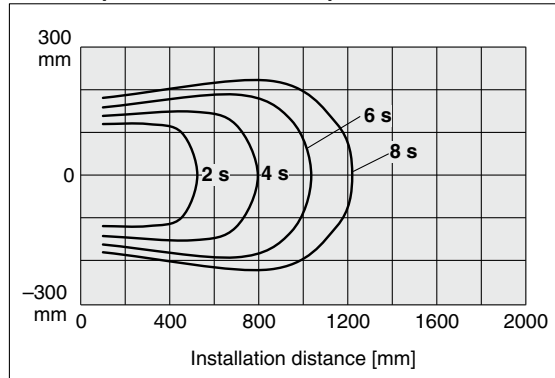

IZF31 (Air flow level: 10)

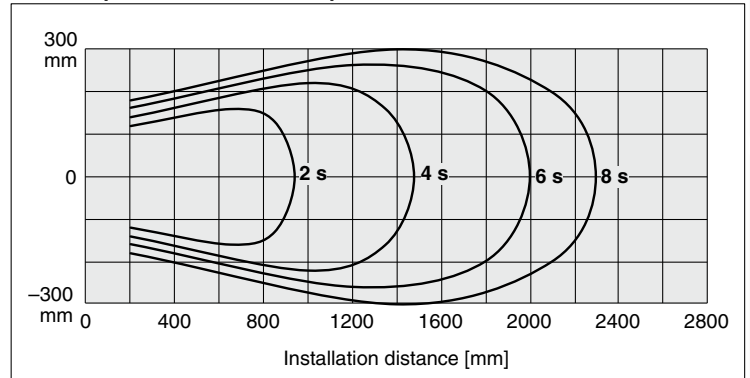

IZF21 (Air flow level: 1)

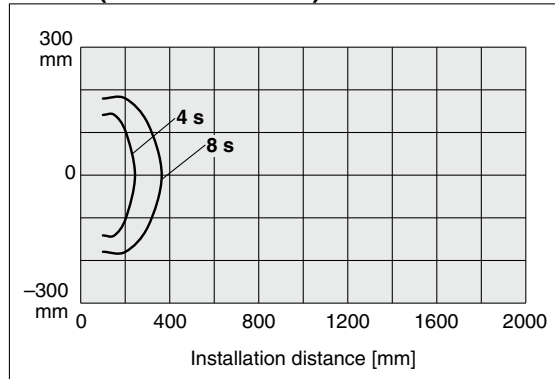

IZF31 (Air flow level: 1)

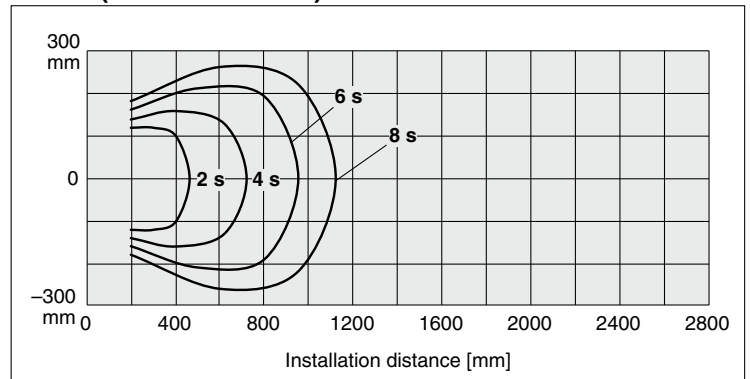

IZF21-W (With adjustable louver: Angle setting 1, Air flow level: 10)

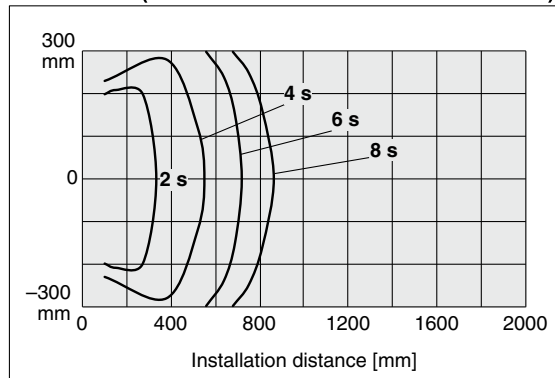

IZF31-W (With adjustable louver: Angle setting 1, Air flow level: 10)

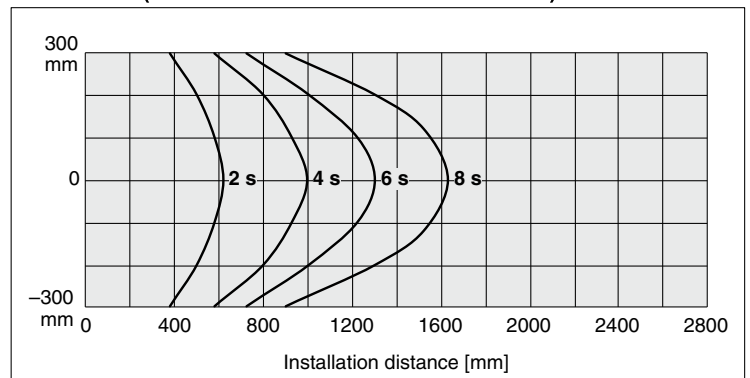

IZF21-W (With adjustable louver: Angle setting 5, Air flow level: 10)

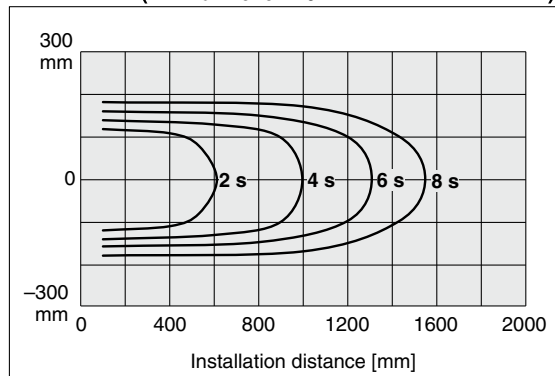

IZF31-W (With adjustable louver: Angle setting 5, Air flow level: 10)

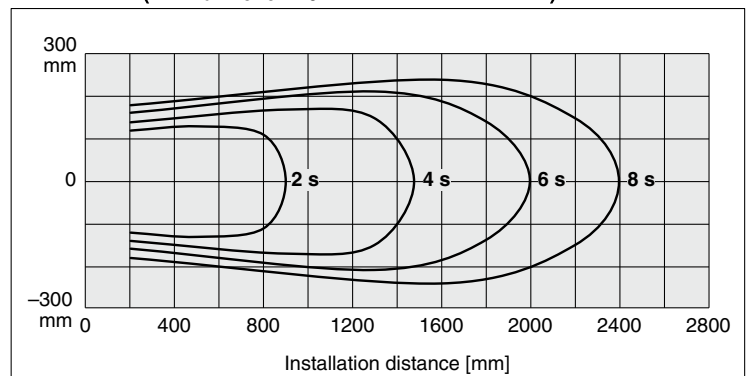

Fan Type Ionizer



IZF21/31 Series



How to Order

IZF **21** - - **B**

Model

Symbol	Max. air flow
21	1.8 m ³ /min
31	4.4 m ³ /min

Input/Output

Nil	NPN input/output
P	PNP input/output

Power supply cable, AC adapter

Nil	With power supply cable (3 m)
Z	With power supply cable (10 m)
Q	With AC adapter (with AC cord)
R	With AC adapter (without AC cord)
N	None

Air suction side filter

Nil	None
U	With filter*1

*1 Filter + Filter holder

Automatic cleaning unit, Louver (Refer to page 12 for details.)

Nil	None
S	With automatic cleaning unit
W	With adjustable louver
Y	With automatic cleaning unit + adjustable louver

Bracket

Nil	None
B	With bracket

Accessories (for Individual Parts)

Emitter cartridge

IZF **21** - NT

• Model

21	For IZF21
31	For IZF31



Power supply cable

IZS41 - CP

• Power supply cable

Nil	Power supply cable (3 m)
Z	Power supply cable (10 m)

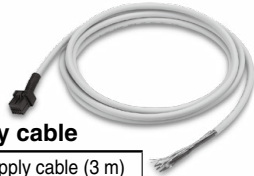

IZS41 - CP **02** - X13

• Power supply cable length

01	Total length: 1 m
02	Total length: 2 m
...	...
19	Total length: 19 m
20	Total length: 20 m

* Available in 1 m increments from 1 m to 20 m.
Use standard power supply cables for 3 m and 10 m lengths.

AC adapter

IZF21 - C **G1**

• AC adapter

G1	AC adapter (with AC cord)
G2	AC adapter (without AC cord)

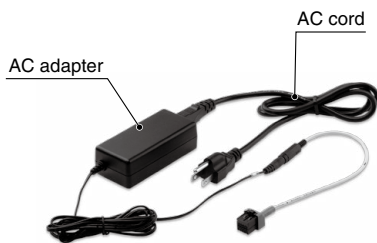

Adjustable louver

IZF **21** - HW

• Model

21	For IZF21
31	For IZF31



Bracket

IZF **21** - B1

• Model

21	For IZF21
31	For IZF31

* 4 retaining bolts are included.



Automatic cleaning unit

IZF **21** - HS

• Model

21	For IZF21
31	For IZF31

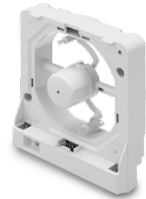

Cleaning arm (for Automatic cleaning unit)

IZF **21** - M3

• Model

21	For IZF21
31	For IZF31

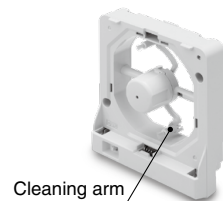

Cleaning arm
* Removable

Air suction side filter

IZF **21** - F **L**

• Model

21	For IZF21
31	For IZF31

• Air suction side filter

L	Filter
U	Filter + Filter holder

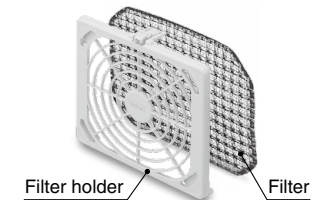

Accessories Sold Separately

Cleaning kit

IZS30 - M2

(With 1 felt pad, 1 rubber grindstone, and 2 replacement felt pads)

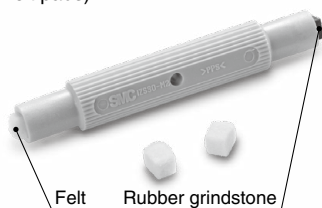

IZS30 - A0201

(10 replacement felt pads)



IZS30 - A0202

(1 replacement rubber grindstone)



Adjustment screwdriver

IZS30 - M1



IZF21/31 Series

Specifications

Model		IZF21-□	IZF21-P	IZF31-□	IZF31-P
		NPN	PNP	NPN	PNP
Maximum air flow		1.8 m ³ /min		4.4 m ³ /min	
Applied voltage		±5 kV			
Ion generation method		Corona discharge type			
Method of applying voltage		DC type			
Offset voltage (Ion balance)^{*1}		±5 V			
Power supply voltage		21.6 to 26.4 VDC (Within 24 VDC ±10%)			
Current consumption		0.9 A or less		1.3 A or less	
Input signal	Ionizer stop signal	Connect with 0 V Voltage range: 5 VDC or less Current consumption: 5 mA or less	Connect with +24 V Voltage range: 19 VDC to power supply voltage Current consumption: 5 mA or less	Connect with 0 V Voltage range: 5 VDC or less Current consumption: 5 mA or less	Connect with +24 V Voltage range: 19 VDC to power supply voltage Current consumption: 5 mA or less
	Cleaning input signal				
Output signal	Maintenance signal	Maximum load current: 100 mA Residual voltage: 1 V or less (Load current: 100 mA)	Maximum load current: 100 mA Residual voltage: 1 V or less (Load current: 100 mA)	Maximum load current: 100 mA Residual voltage: 1 V or less (Load current: 100 mA)	Maximum load current: 100 mA Residual voltage: 1 V or less (Load current: 100 mA)
	Error signal	Maximum applied voltage: 26.4 VDC		Maximum applied voltage: 26.4 VDC	
Ambient temperature		Operating: 0 to 50°C Stored: -10 to 60°C			
Ambient humidity		Operating, Stored: 35 to 80%RH (No condensation)			
Material		Case: ABS/PBT/Stainless steel Emitter: Tungsten			
Impact resistance		100 m/s ²			
Standards/Directive		CE (EMC directive: 2014/30/EU)			

*1 Based on ANSI/ESD-STM3.1-2015 standards

AC Adapter Specifications

Input voltage	100 to 240 VAC, 50/60 Hz
Output voltage	24 VDC
Output current	1.9 A max
Ambient temperature	0 to 40°C, Stored: -20 to 65°C
Ambient humidity	Operating, Stored: 5 to 95%RH (No condensation)
Weight	375 g (including AC cord, connector)
Standards/Directive	CE, cUL

Weights

	IZF21	IZF31
Body	430 g	605 g
Bracket	146 g	220 g
Automatic cleaning unit	96 g	127 g
Louver	33 g	58 g
Filter	15 g	26 g

Functions and Indications

No.	Name	Panel display	Type	Description
1	Power supply switch	POWER	Switch	Switch to turn this product ON and OFF.
2	Power supply indicator	PWR	LED (Green/Red)	Green lights up when the power supply is ON. Green flashes if the power supply is abnormal. Red flashes if the CPU is abnormal.
3	Static neutralization operation/Incorrect high voltage indicator	ION/HV	LED (Green/Red)	Green lights up when static neutralization is operated. Red lights up if incorrect high voltage is detected. Red flashes if the CPU is abnormal.
4	Error indicator	ALM	LED (Red)	Red lights up if fan motor failure or automatic cleaning failure is detected. Red flashes if the CPU is abnormal.
5	Maintenance indicator	NDL	LED (Green/Red)	Green lights up when emitters require cleaning. Green flashes when automatic cleaning is performed. Red flashes if emitter cartridge mounting failure, automatic cleaning failure or CPU failure is detected.
6	Balance adjustment	ADJUST	Trimmer	Adjusts offset voltage (ion balance).
7	Air flow adjustment	BLOW SPEED	Rotary switch	Adjusts air flow with fan.

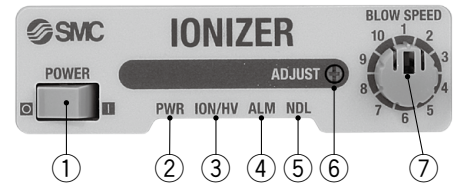

Alarm

Alarm name	Output signal	LED ON	LED (Flashes at 1 Hz)	Operation after alarm generated	Description	Action to reset alarm
Power supply failure	Error signal OFF (B contact)	—	PWR (Green)	Stop	Connected power supply voltage is outside of specification.	Reset automatically.
Incorrect high voltage	Error signal OFF (B contact)	ION/HV (Red)	—	Stop	If an abnormal high voltage discharge occurs.	Input the ionizer stop signal or supply power again.
Fan motor failure	Error signal OFF (B contact)	ALM (Red)	—	Stop	Incorrect ionizer operation due to foreign matter in fan motor	Input the ionizer stop signal or supply power again.
CPU failure	Error signal OFF (B contact)	—	PWR (Red) ION/HV (Red) ALM (Red) NDL (Red)	Stop	CPU error due to noise etc.	Supply power again.
Excess current on output circuit	Error signal OFF (B contact) Maintenance signal OFF (A contact)	—	—	Continue	If excess current is present on the output circuit and protection circuit is activated.	Reset automatically.
Maintenance warning	Maintenance signal ON (A contact)	NDL (Green)	—	Continue	When static electricity neutralization performance is reduced due to contamination or wear of the emitters.	Input the ionizer stop signal or supply power again.
Emitter cartridge mounting failure	Error signal OFF (B contact)	NDL (Red)	—	Stop	Emitter cartridge is not mounted.	Supply power again.
Automatic cleaning failure	Error signal OFF (B contact)	ALM (Red)	NDL (Red)	Stop	Error during automatic cleaning operation	Supply power again.

Wiring

Pin no.	Cable color	Signal name	Signal direction	Description
A1	Brown	+24 VDC	IN	Power supply connection to operate this product.
B1				
A2	Blue	0 V	IN	
B2				
A3	Green	F. G.	—	
B3	Yellowish green	Ionizer stop signal	IN	Signal input to turn ON/OFF the ventilation with fan and ion generation. NPN type: To stop fan and ion generation, connect to 0 V. (It operates when disconnected) PNP type: To stop fan and ion generation, connect to +24 VDC. (It operates when disconnected)
A4	Gray	Cleaning signal	IN	When an automatic cleaning unit is fitted, cleaning of the emitters will start.
B4	Yellow	Maintenance signal	OUT (A contact)	Turns ON when cleaning due to emitter contamination and/or replacement due to wear is required or when automatic cleaning is being performed (when an automatic cleaning unit is fitted). Turns OFF during output circuit over current error.
A5	Purple	Error signal	OUT (B contact)	Turns OFF if power supply failure, incorrect high voltage, fan motor failure, CPU failure, excess current on the output circuit, emitter cartridge mounting failure, or automatic cleaning failure (for product with automatic cleaning function) is detected. (ON when there is no problem)
B5	White	—	—	—

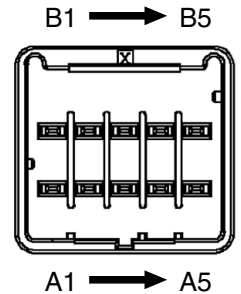

Wiring Circuit

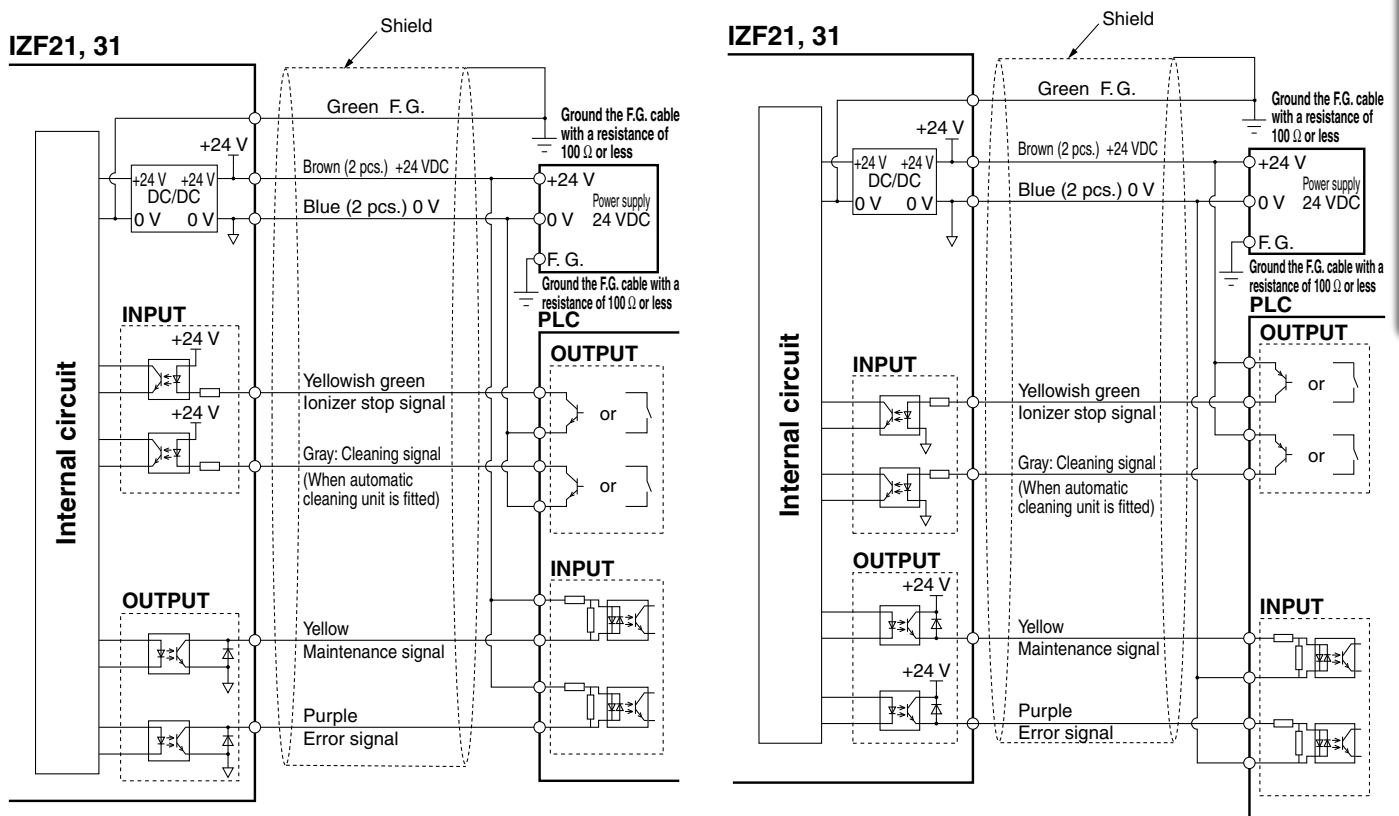

Technical Data

IZF21/31

IZF10/IZF10R

IZF21/31 Series

Operation Chart

Operation Chart 1

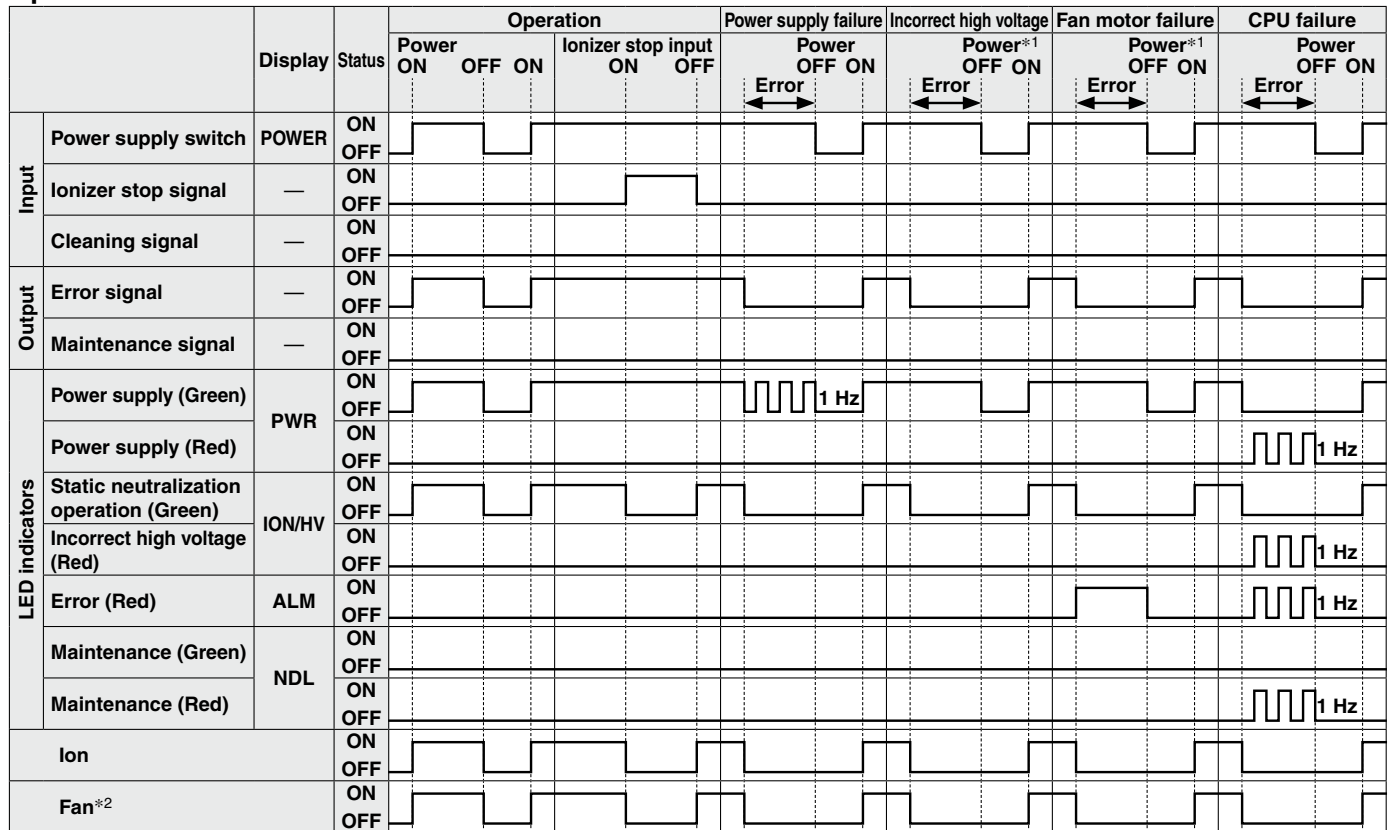

Operation Chart 2

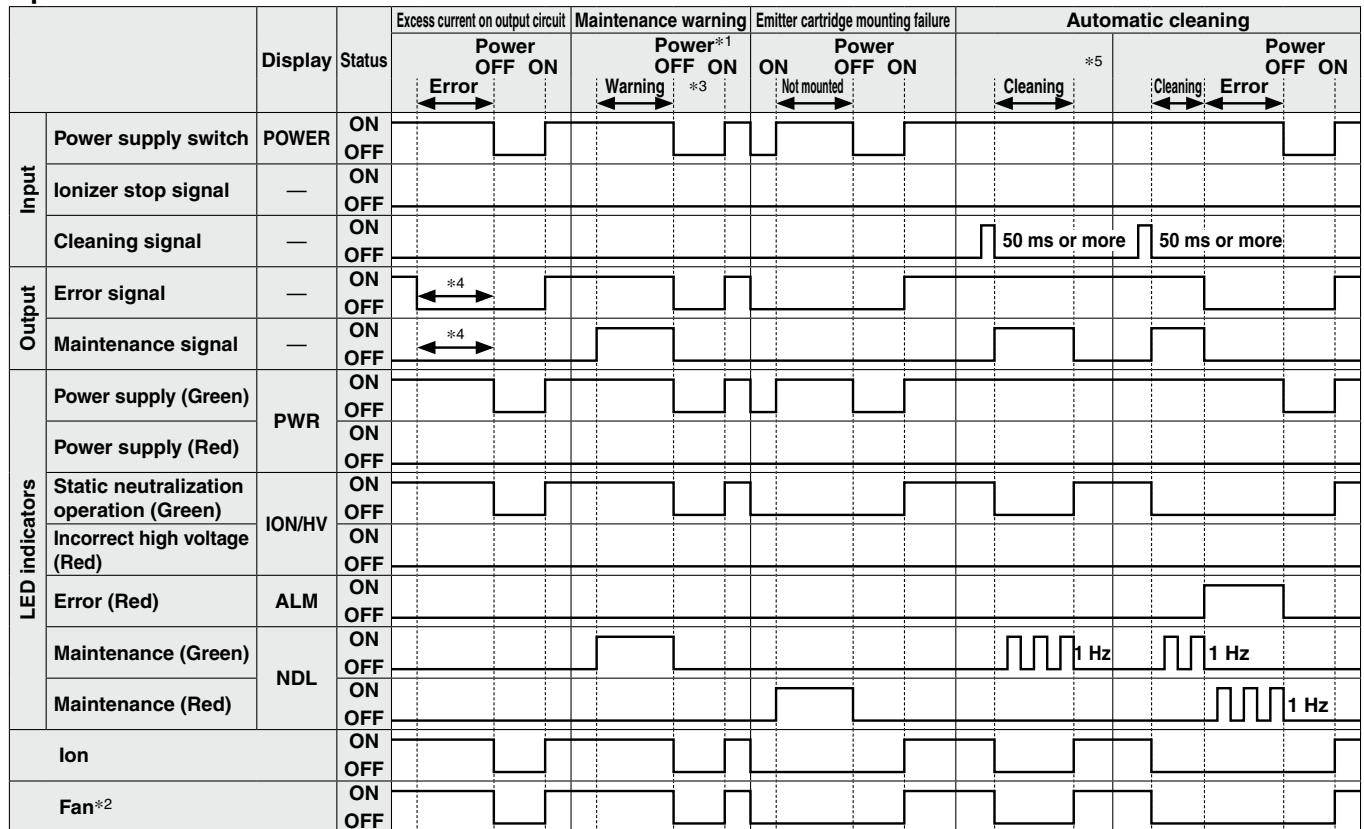

*1 Incorrect high voltage, fan motor failure, and maintenance warning can also be released by the ionizer stop signal after resolving the error.

*2 Fan rotation stops gradually because of its rotational inertia.

*3 Ensure the power supply is turned off before clearing errors or cleaning emitters. If an alarm continues to be generated even after cleaning, the emitters may be worn out or damaged. If wear or damage to the emitters is detected, replace the emitter cartridge with a new one.

*4 When excess current flows to the error signal or maintenance signal, the signal will be turned OFF to protect the output circuit.

*5 The cleaning time is approximately 2 seconds.

Dimensions

IZF21-□-□□□□

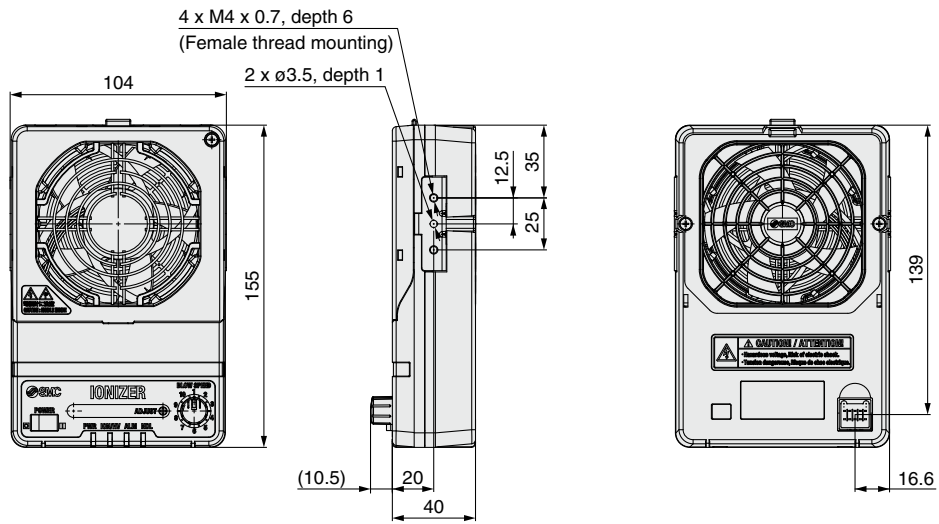

Bracket

IZF21-□-□B□□

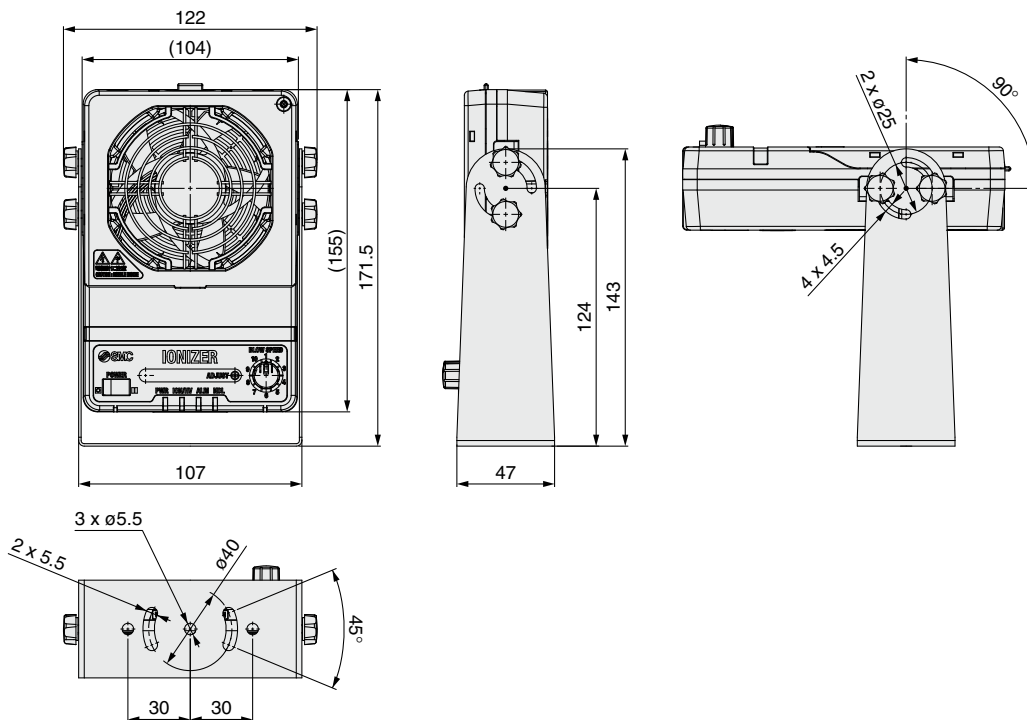

Technical Data

IZF21/31

IZF10/IZF10R

IZF21/31 Series

Dimensions

IZF31-□-□□□□

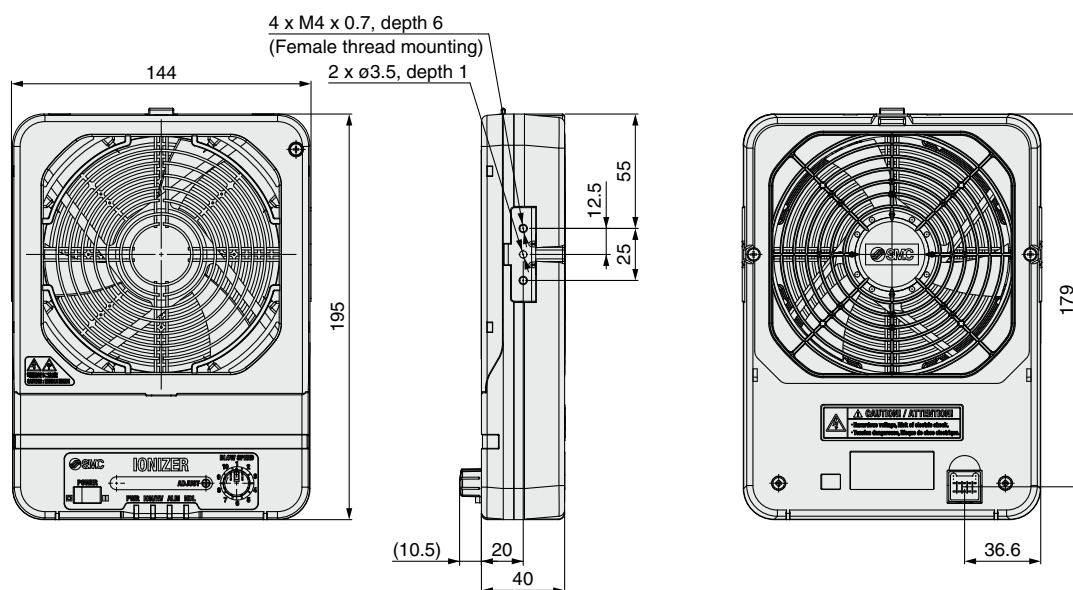

Bracket

IZF31-□-□B□□

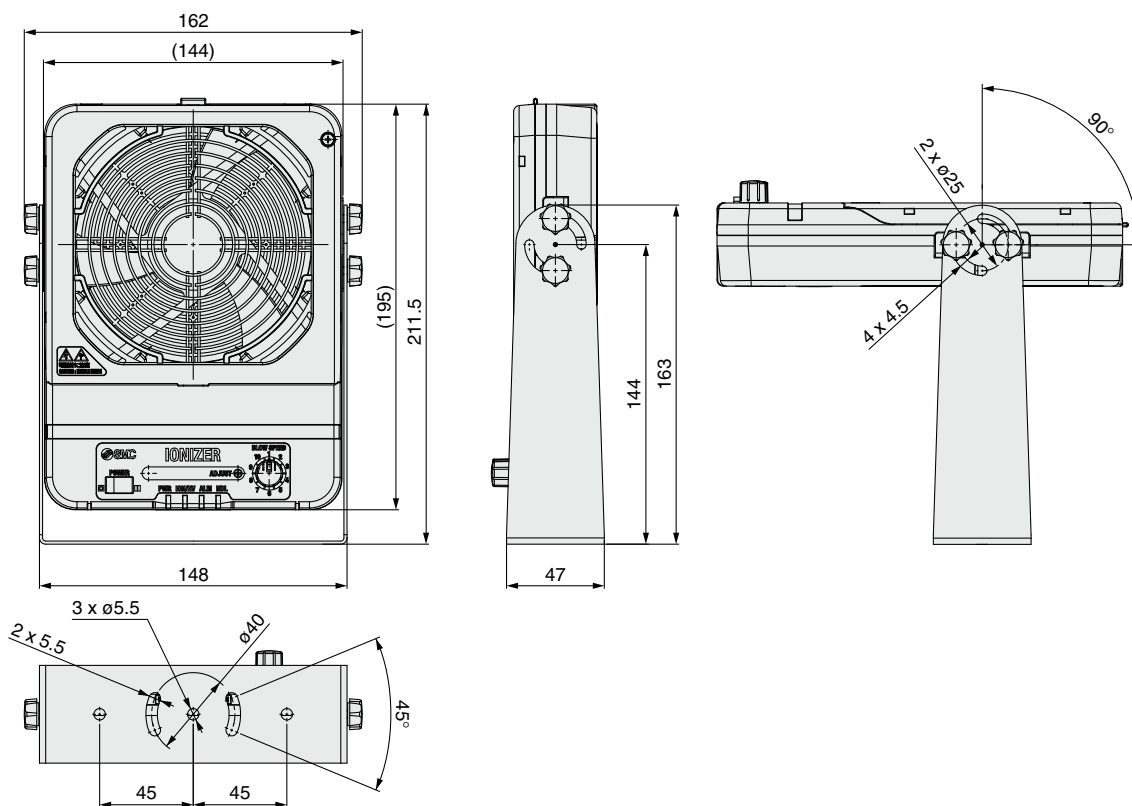

Dimensions

With automatic cleaning unit
IZF21-□-□□S□

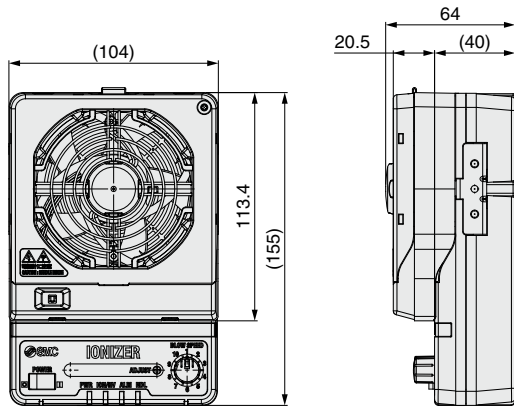

IZF31-□-□□S□

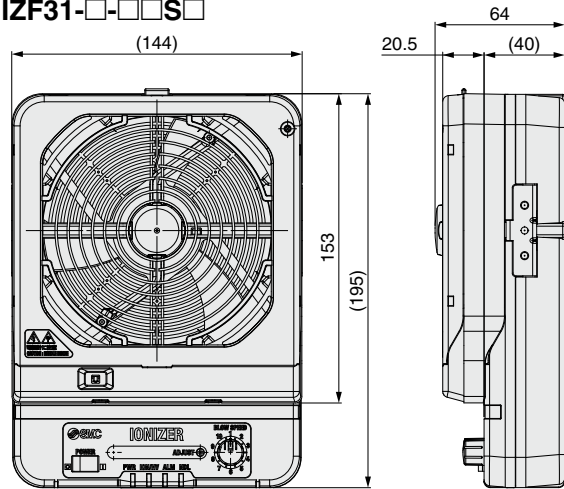

With adjustable louver
IZF21-□-□□W□

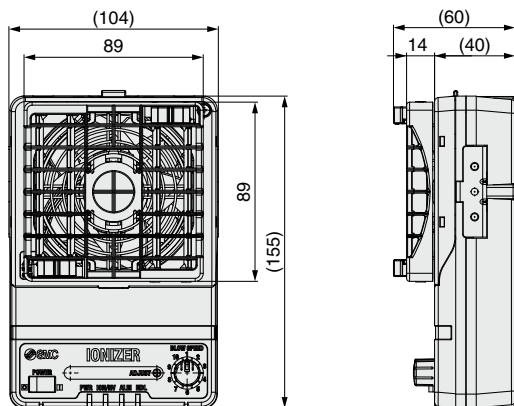

IZF31-□-□□W□

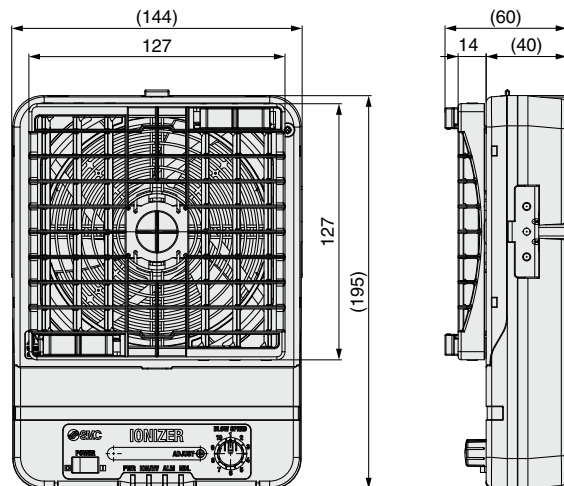

With filter

IZF21-□-□□□U

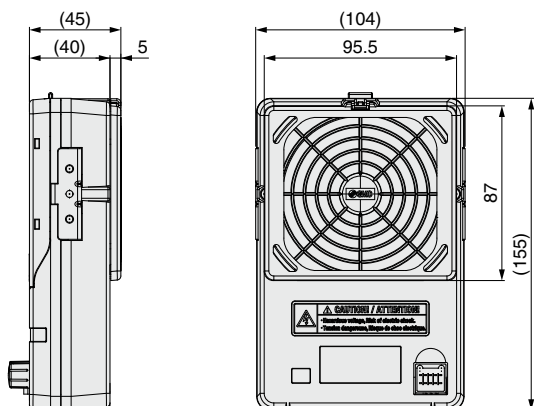

IZF31-□-□□□U

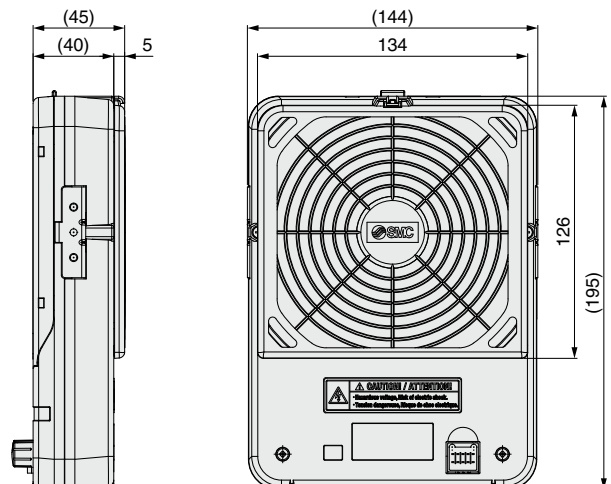

IZF21/31 Series

Dimensions

Power supply cable IZS41-CP

Part no.	L
IZS41-CP	3000 $^{+60}_0$
IZS41-CPZ	9850 $^{+100}_0$

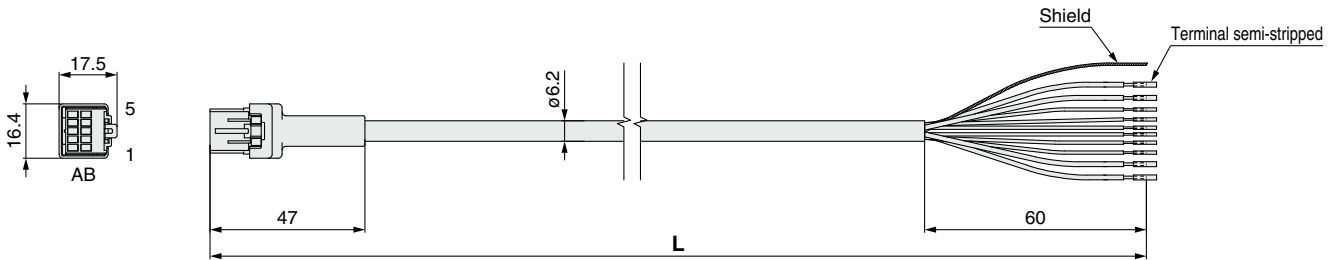

Cable Specifications

No. of cable wires/Size	10 pcs./AWG20 (4 pcs.), AWG28 (6 pcs.)	
Conductor	Nominal cross section	0.54 mm ² (4 pcs.) 0.09 mm ² (6 pcs.)
	Outside diameter	0.96 mm ² (4 pcs.) 0.38 mm ² (6 pcs.)
Insulator	Outside diameter	1.4 mm Blue, Brown 0.7 mm White, Green, Light green, Purple, Gray, Yellow
	Material	Heat resistant PVC
Sheath	Material	Heat resistant PVC
	Outside diameter	6.2 mm

AC adapter IZF21-CG1 (with AC cord)

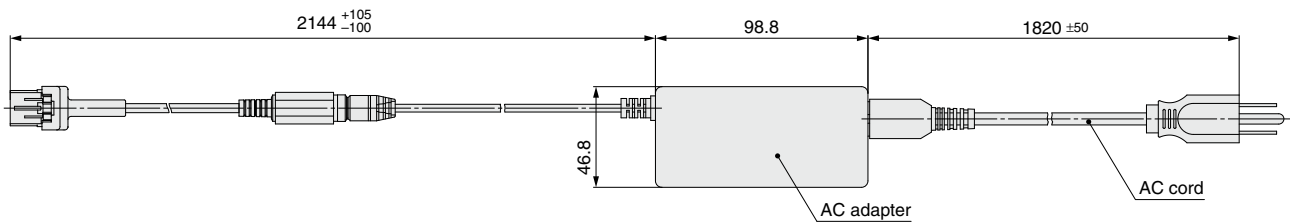

IZF21-CG2 (without AC cord)

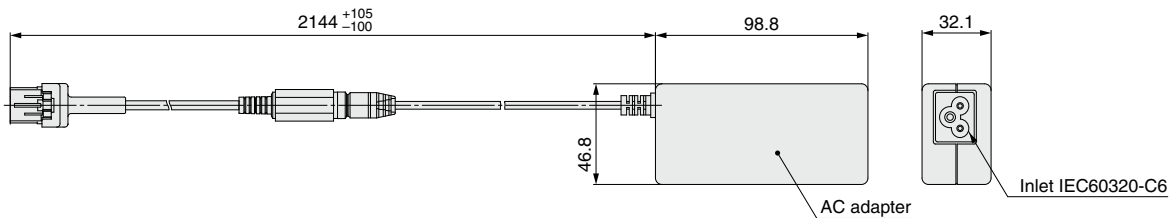

* The input (AC) side and output (DC) side of the AC adapter are not isolated.
If using the AC adapter as DC power supply for a different product, this may cause electric shock or malfunction.
Do not use the AC adapter for the DC power supply of a different product.

IZF10/IZF10R Series Technical Data



Static Neutralization Performance

* Static neutralization characteristics are based on data using a charged plate (dimensions: 150 mm x 150 mm, capacitance: 20 pF) as defined in the U.S. ANSI standards (ANSI/ESD STM3.1-2015). Use this data only as a guideline for model selection because the values vary depending on the material and/or size of the subject.

① Installation Distance and Discharge Time (Discharge Time from 1000 V to 100 V)

IZF10

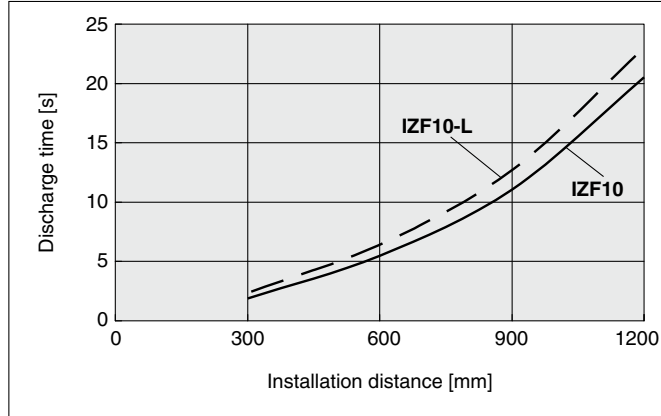

IZF10R

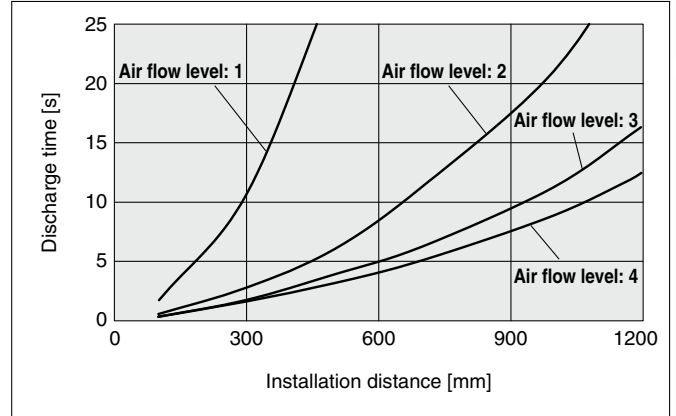

② Static Neutralization Range

IZF10

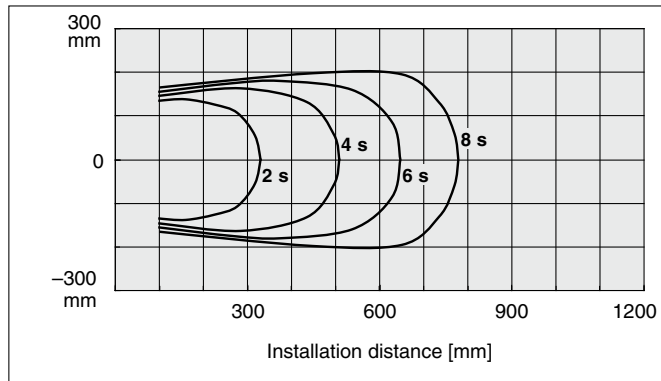

IZF10-L

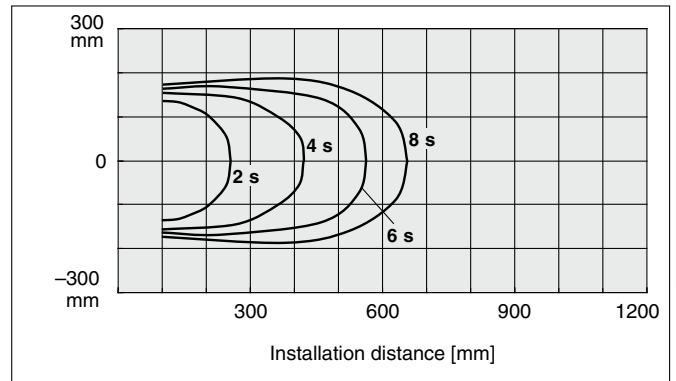

IZF10R (Air flow level: 4)

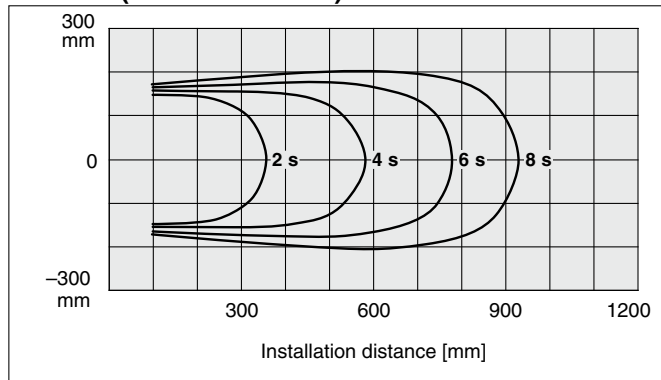

IZF10R (Air flow level: 1)

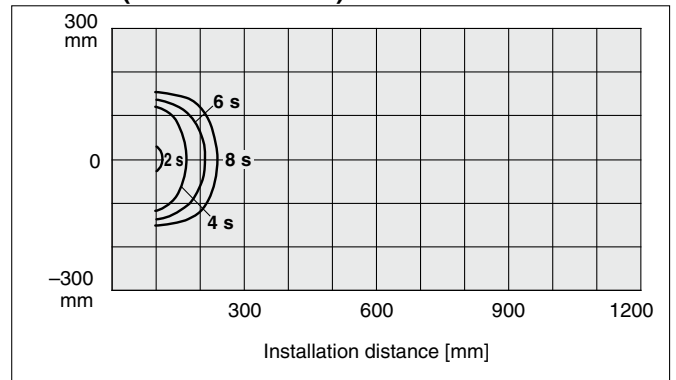

IZF
10

IZF
10R

Fan Type Ionizer



IZF10/IZF10R Series

How to Order



Without Flow Rate Adjustment Function

IZF10 - [] - [] - [] B

Compact fan type

Air flow

Nil	0.66 m ³ /min
L	0.46 m ³ /min

With flow rate adjustment function

With Flow Rate Adjustment Function

IZF10R - [] - [] B

Compact fan type

With flow rate adjustment function
(0.19 to 0.80 m³/min)

Bracket

Nil	None
B	With bracket

Output

Nil	NPN output
P	PNP output

Power supply cable, AC adapter

Nil	With power supply cable (3 m)
Z	With power supply cable (10 m)
H*1	e-con connector
Q	With AC adapter (with AC cord)
R	With AC adapter (without AC cord)
N	None

*1 A power supply connector for customers supplying their own cable
Can only be used if the IZF10 is selected.

Accessories (for Individual Parts)

Power supply cable

IZF10 - **C** P IZF 10 IZF 10R

• **Power supply cable**

P	Power supply cable (3 m)
PZ	Power supply cable (10 m)

• **Flow rate adjustment function**

Nil	Without flow rate adjustment function
R	With flow rate adjustment function



Without flow rate adjustment function



With flow rate adjustment function

AC adapter

IZF10 - **C** G1 IZF 10 IZF 10R

• **AC adapter**

G1	AC adapter (with AC cord)
G2	AC adapter (without AC cord)

* AC cord is only for use in Japan.
(Rated voltage 125 V, Plug JIS C8303, Inlet IEC60320-C8)

• **Flow rate adjustment function**

Nil	Without flow rate adjustment function
R	With flow rate adjustment function

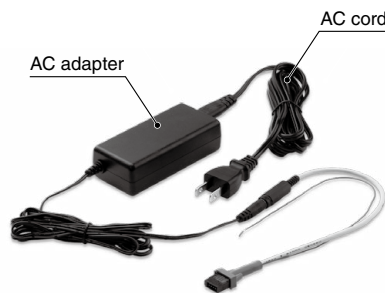

Without flow rate adjustment function

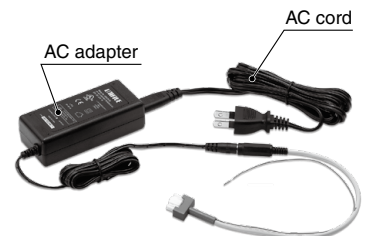

With flow rate adjustment function

e-con connector

IZF 10

ZS-28-C



* Applicable wire size: AWG26 to 24,
Conductor cross sectional area:
0.14 to 0.2 mm², Finished outside
diameter: ø0.8 to ø1.0 mm

Cartridge case

IZF 10 IZF 10R

IZF 10 - A1

• **Flow rate adjustment function**

10	Without flow rate adjustment function
10R	With flow rate adjustment function



For with flow rate adjustment function

Bracket

IZF 10 IZF 10R

IZF10 - B1

* 4 retaining bolts are included.



Accessories Sold Separately

IZF 10 IZF 10R

Cleaning kit

IZS30 - M2

(With 1 felt pad, 1 rubber grindstone, and 2 replacement felt pads)

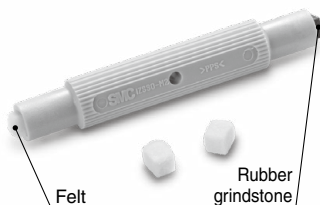

IZS30 - A0201

(10 replacement felt pads)



IZS30 - A0202

(1 replacement rubber grindstone)



Adjustment screwdriver

IZS30 - M1



IZF10/IZF10R Series

Specifications

Model	IZF10-□□	IZF10-L-□□	IZF10R-□□	IZF10-P-□□	IZF10-LP-□□	IZF10R-P-□□
Maximum air flow	0.66 m ³ /min	0.46 m ³ /min	0.80 m ³ /min (Max.)	0.66 m ³ /min	0.46 m ³ /min	0.80 m ³ /min (Max.)
Ion generation method	Corona discharge type					
Method of applying voltage	DC type					
Applied voltage	±5 kV					
Offset voltage (ion balance)*1	Within ±13 V					
Power supply voltage	21.6 to 26.4 VDC (Within 24 VDC ±10%)					
Power consumption	220 mA or less	140 mA or less	270 mA or less	250 mA or less	170 mA or less	270 mA or less
Switch output	NPN open collector output Maximum load current: 80 mA Residual voltage: 1 V or less (Load current: 80 mA) Maximum load voltage: 26.4 VDC		NPN open collector output Maximum load current: 150 mA Residual voltage: 1 V or less (Load current: 150 mA) Maximum load voltage: 26.4 VDC		PNP open collector output Maximum load current: 80 mA Residual voltage: 1 V or less (Load current: 80 mA)	
Ambient temperature	Operating: 0 to 50°C, Stored: -10 to 60°C					
Ambient humidity	Operating, Stored: 35 to 80%RH (No condensation)					
Material	Case: ABS/Stainless steel, Emitter: Tungsten					
Weight	280 g (With bracket: 360 g)		260 g (With bracket: 340 g)		280 g (With bracket: 360 g)	
Standards/Directive	CE (EMC directive: 2004/108/EC)		CE (EMC directive: 2014/30/EU)		CE (EMC directive: 2004/108/EC)	

*1 Based on ANSI/ESD-STM3.1-2015 standards

AC Adapter (IZF10/10R-CG1, IZF10/10R-CG2)

Input voltage	100 to 240 VAC, 50/60 Hz
Output voltage	24 VDC
Output current	1 A max
Ambient temperature	0 to 40°C, Stored: -20 to 65°C
Ambient humidity	Operating, Stored: 10 to 90%RH (No condensation)
Standards/Directive	CE, cUL

Functions and Indications

No.	Name	Panel display	Type	Description
1	Power supply switch	—	Switch	Switch to turn this product ON and OFF.
2	Power supply indicator	—	LED (Green/Orange)	The LED is ON green when power is supplied to this product, and is ON orange during an incorrect high voltage alarm or output signal over current alarm.
3	Error indicator	ALARM	LED (Red)	The LED turns ON when an incorrect voltage alarm is generated for 100 ms or more.
4	Maintenance indicator	NDL	LED (Green)	The LED is ON green when the emitter is contaminated or worn.
5	Air flow adjustment*1	BLOW SPEED	Rotary switch	Adjusts air flow with fan.
6	Balance adjustment	—	Trimmer	Adjusts offset voltage (ion balance).
7	Connector	—	Connector	Connect the power supply cable or AC adapter.

*1 Only for the IZF10R

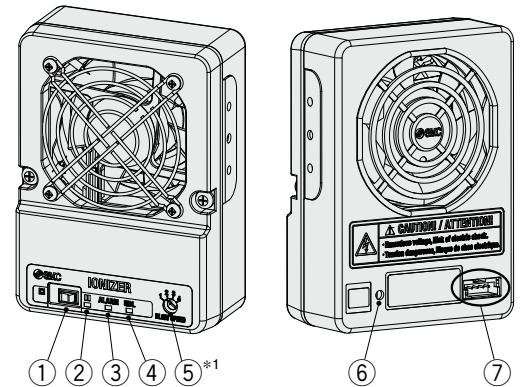

Alarm

Alarm name	Output signal at the time of alarm*1	LED	Operation after alarm generated	Description	Action to reset alarm
Incorrect high voltage	Error signal OFF (B contact)	Power supply (Orange) Error indicator (Red)	Stop	Incorrect function of the high voltage circuit for 100 ms or more.	Supply power again.
Excess current on output circuit	Signal due to excess current OFF	Power supply (Orange)	Continue	Excess current is present on the output circuit.	Reset automatically.
Maintenance warning	Maintenance signal ON (A contact)	Maintenance warning (Green)	Continue	When static electricity neutralization performance is reduced due to contamination or wear of the emitters.	Supply power again.

*1 NPN/PNP open collector output

Wiring: IZF10

Pin no.	Signal name	Description
1	+24 VDC	Power supply connection to operate this product.
2	0 V	
3	F.G.	Ground terminal with 100 Ω or less to use it as a reference electric potential of offset voltage.
4	Error signal	The error signal turns OFF when a high voltage alarm or output signal over current is generated. (ON when there is no problem)

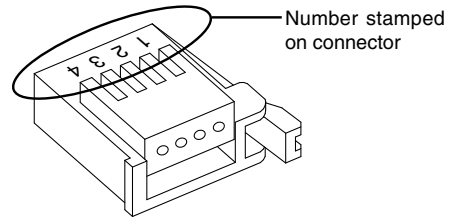

Wiring Circuit: IZF10

NPN output

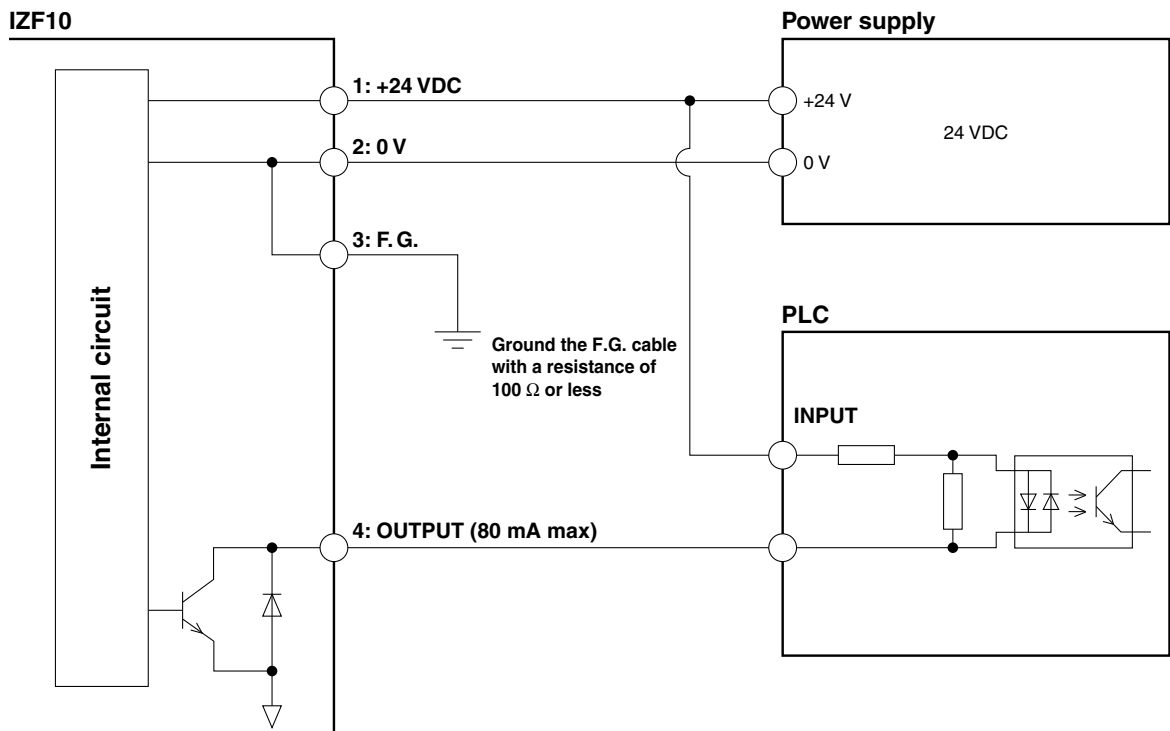

PNP output

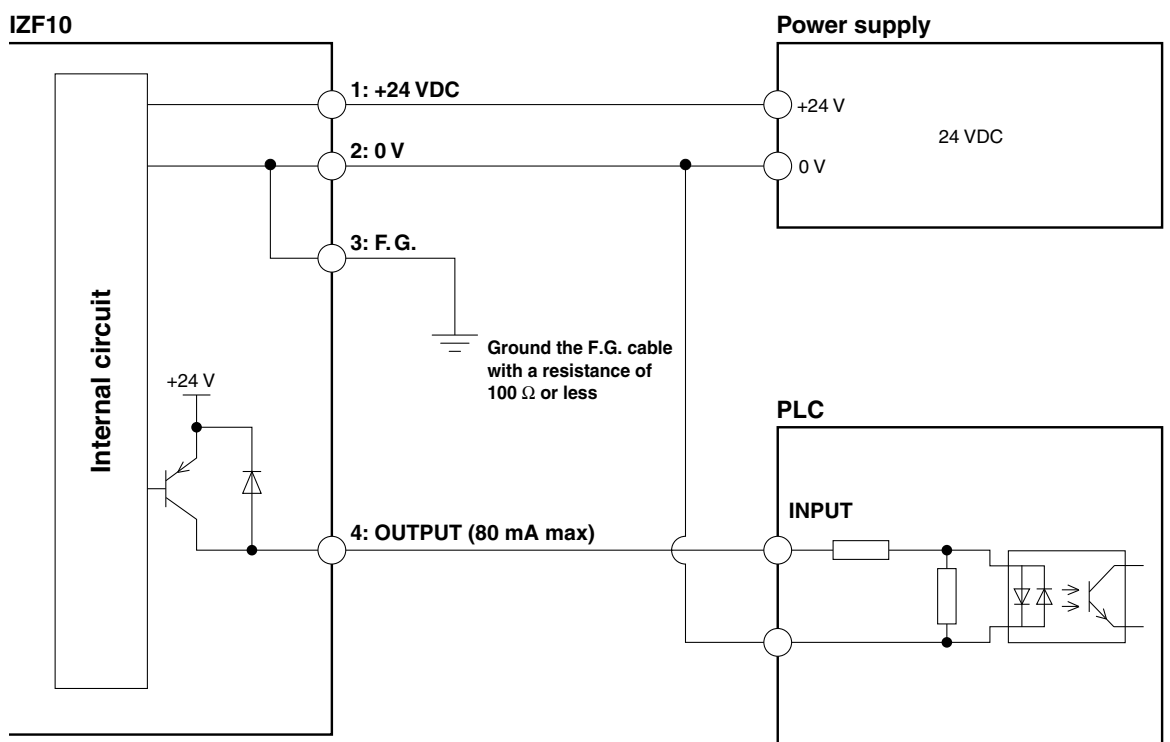

Technical Data

IZF21/31

IZF10/IZF10R

IZF10/IZF10R Series

Wiring: IZF10R

Pin no.	Cable color	Signal name	Conductor size (AWG)	Signal direction	Description
1	Brown	+24 VDC	26	IN	Power supply connection to operate this product.
2	Blue	0 V	26	IN	
3	Green	F.G.	26	—	Ground terminal with 100 Ω or less to use it as a reference electric potential of offset voltage.
4	Yellow	Maintenance signal	26	OUT (A contact)	Turns ON when the emitter is contaminated or worn.
5	Purple	Error signal	26	OUT (B contact)	The error signal turns OFF when a high voltage alarm or output signal over current is generated. (ON when there is no problem)

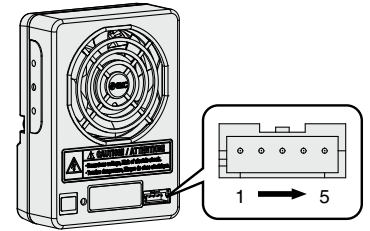

Wiring Circuit: IZF10R

NPN output

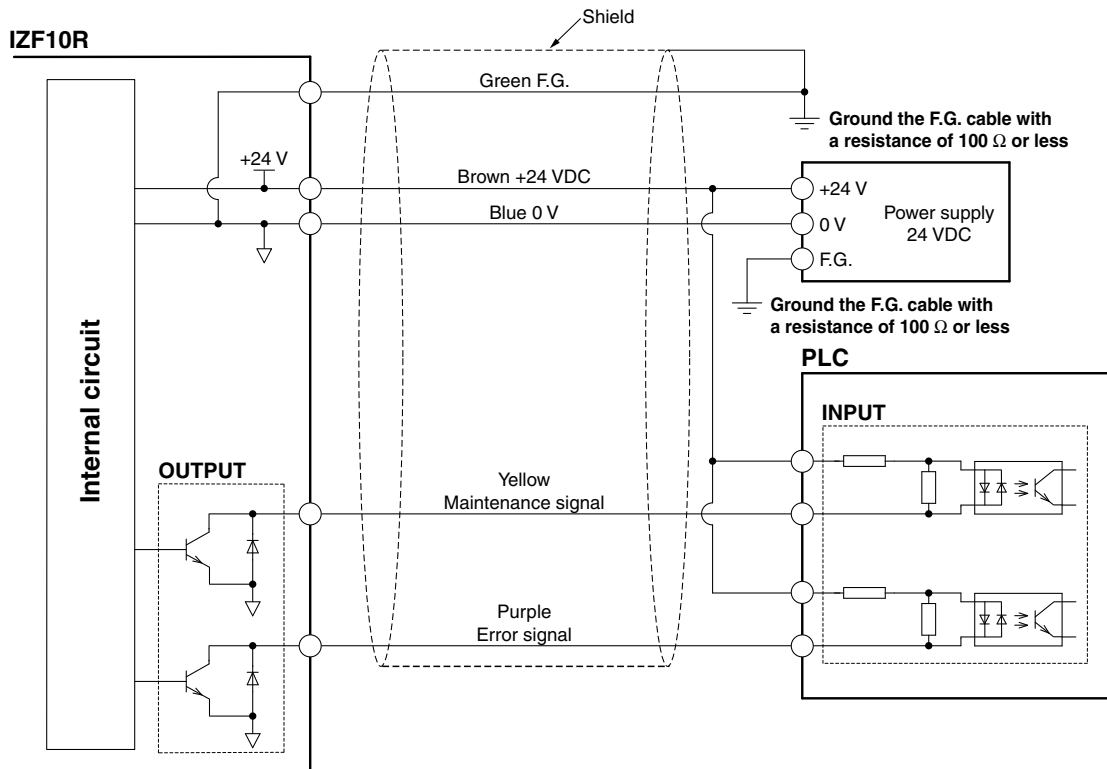

PNP output

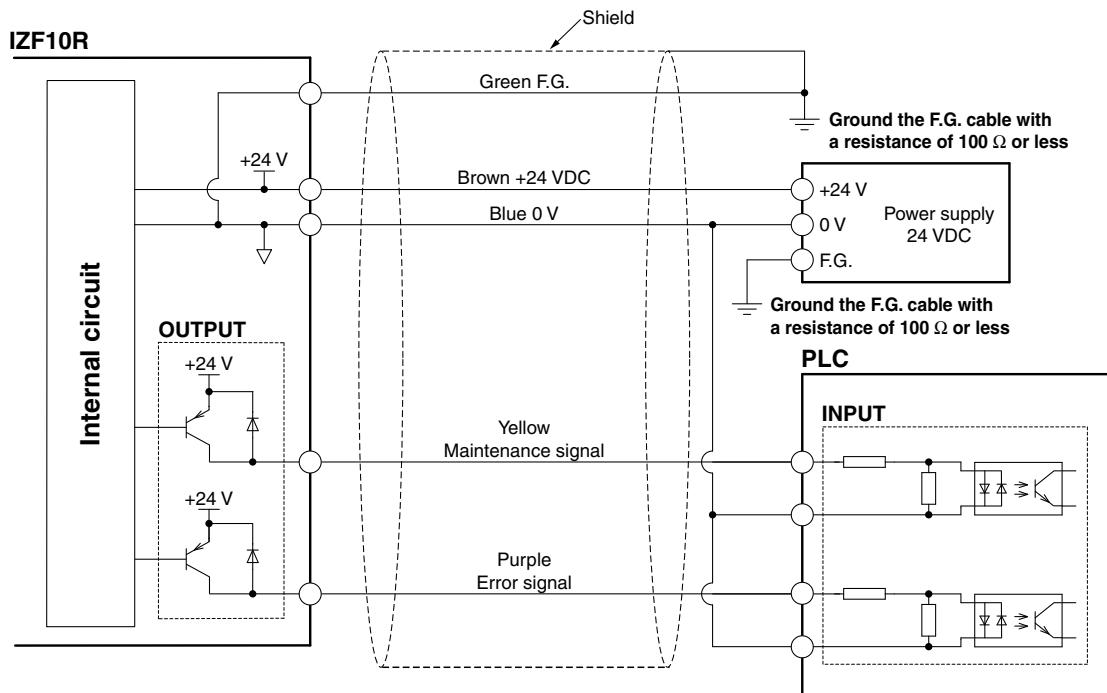

Operation Chart

IZF10 Timing Chart

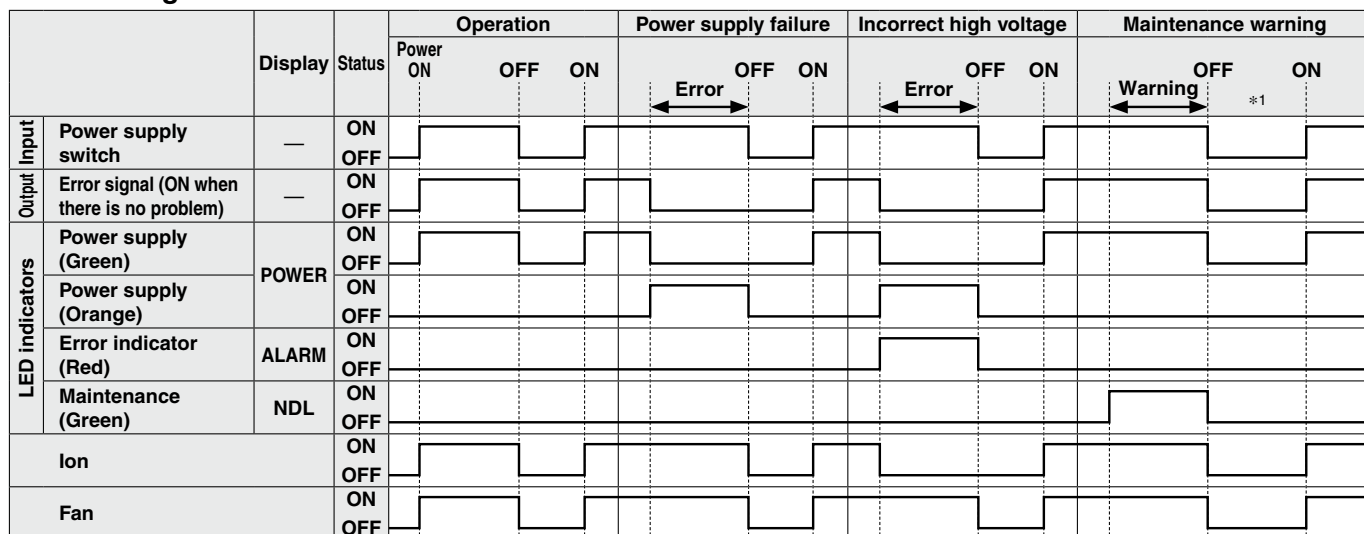

*1 Cleaning or replacing the emitters should never be performed with the power supply ON. If an alarm continues to be generated even after cleaning, the emitters may be worn out or damaged. If wear or damage to the emitters is detected, replace the emitter cartridge with a new one.

IZF10R Timing Chart

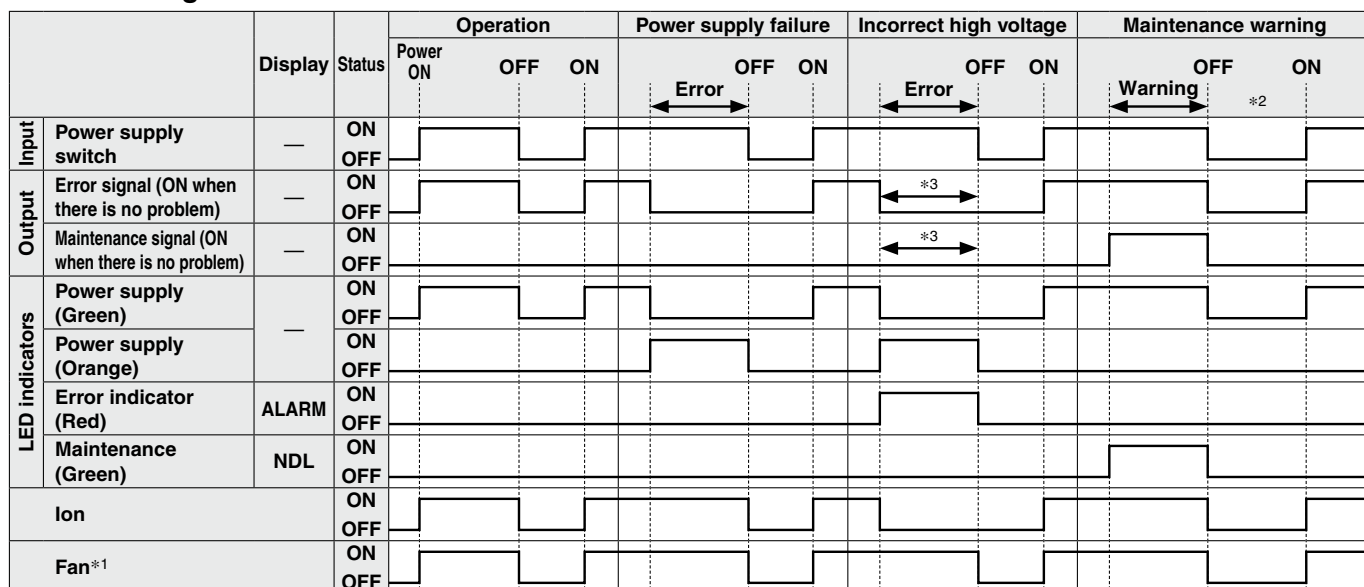

*1 Fan motor rotation does not stop immediately due to inertial force even when the power supply is OFF.

*2 Cleaning or replacing the emitters should never be performed with the power supply ON. If an alarm continues to be generated even after cleaning, the emitters may be worn out or damaged. If wear or damage to the emitters is detected, replace the emitter cartridge with a new one.

*3 When excessive current flows to the output signal, the signal will be turned OFF to protect the output circuit.

Precautions for use in a clean room

When using in a clean room environment, confirm the required cleanliness before use. Fine particles are generated due to wear of emitters and motor sliding during operation.

IZF10/IZF10R Series

Dimensions

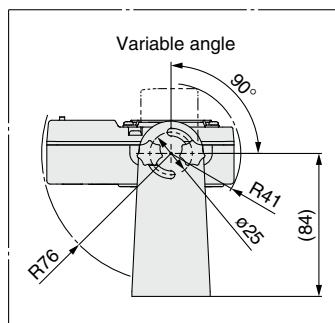
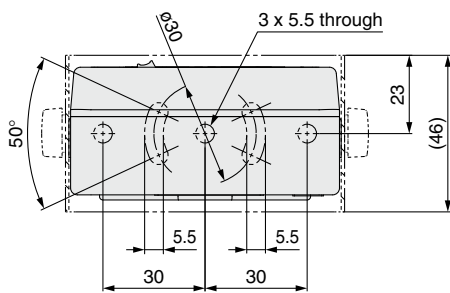
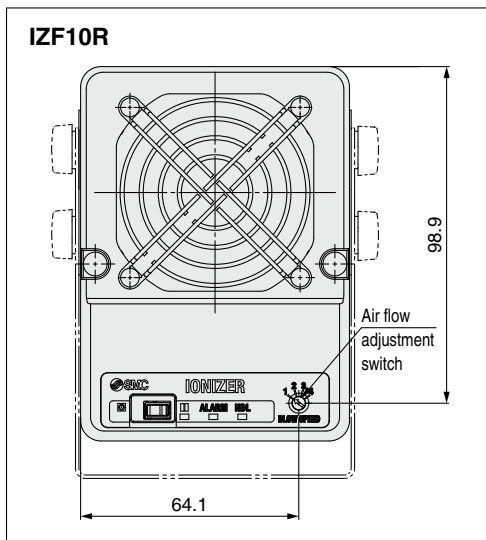
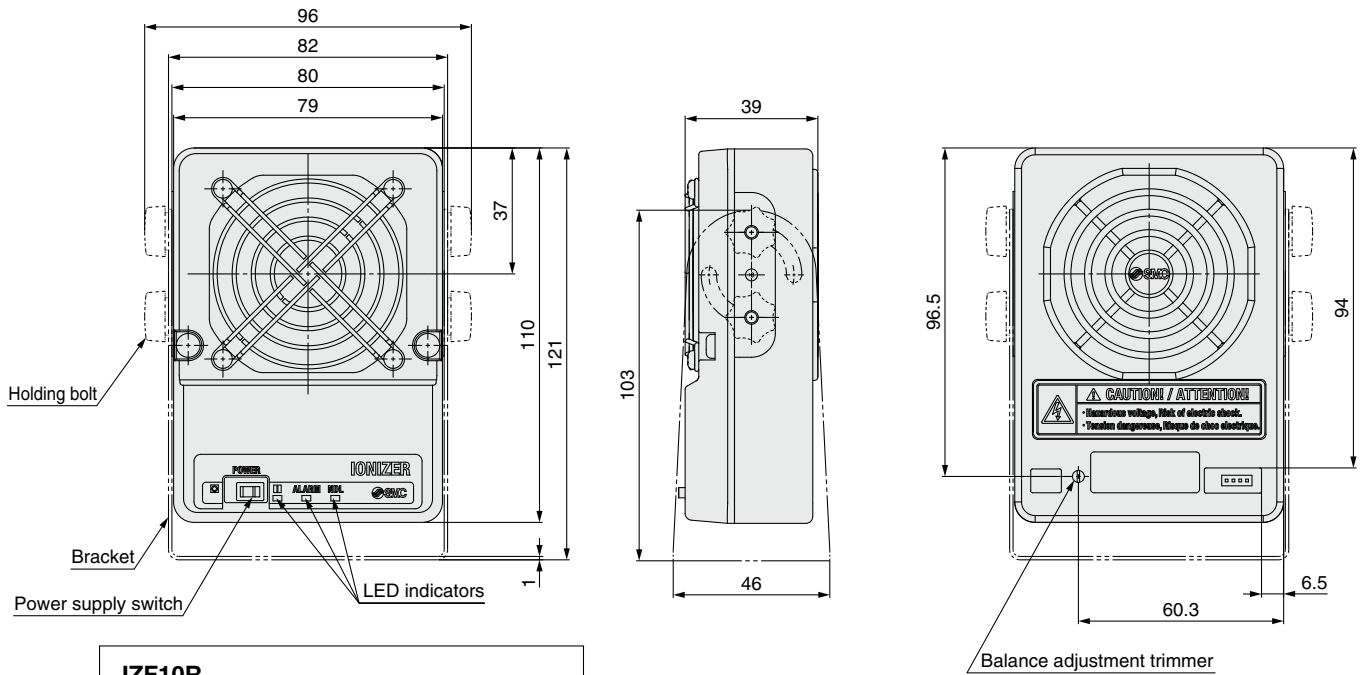

Without bracket

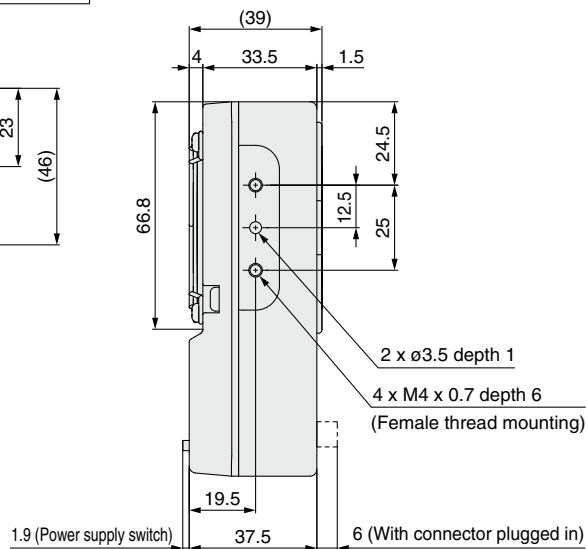

Dimensions

Power supply cable

IZF10-CP□

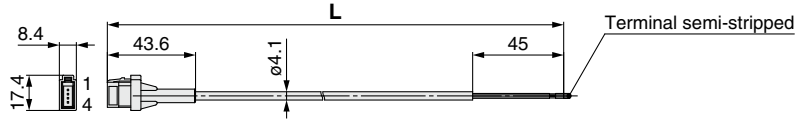

Part no.	L
IZF10-CP	3000 $^{+60}_0$
IZF10-CPZ	9850 $^{+100}_0$

Wiring: IZF10

Pin no.	Cable color	Signal name	Conductor size (AWG)
1	Brown	+24 VDC	24
2	Blue	0 V	24
3	Green	F. G.	24
4	Purple	Error signal	24

IZF10R-CP□

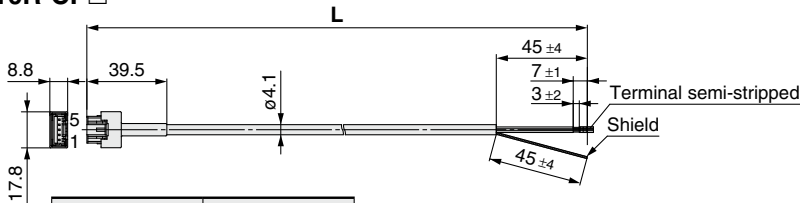

Part no.	L
IZF10R-CP	3000 $^{+60}_0$
IZF10R-CPZ	9850 $^{+100}_0$

Wiring: IZF10R

Pin no.	Cable color	Signal name	Conductor size (AWG)
1	Brown	+24 VDC	26
2	Blue	0 V	26
3	Green	F. G.	26
4	Yellow	Maintenance	26
5	Purple	Error signal	26

AC adapter

IZF10-CG1

With AC cord

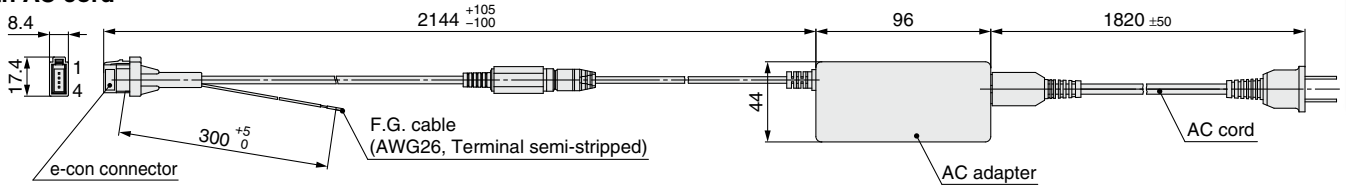

IZF10-CG2

Without AC cord

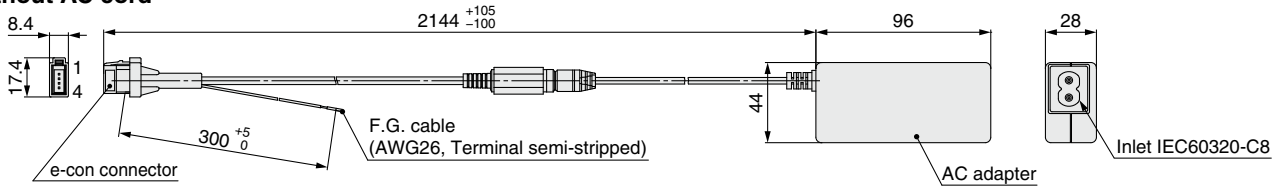

IZF10R-CG1

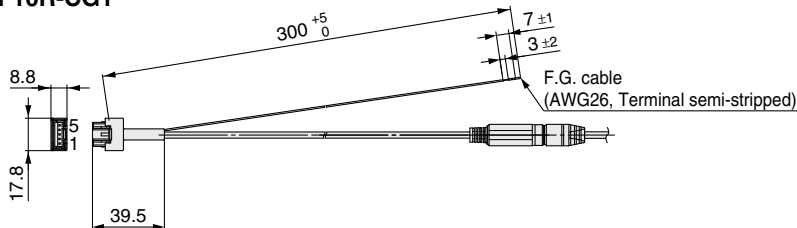

* AC cord is only for use in Japan. (Rated voltage 125 V, Plug JIS C8303, Inlet IEC60320-C8)
External output cannot be used when the AC adapter is being used.



IZF Series

Specific Product Precautions 1

Be sure to read this before handling the products.
Refer to the back cover for safety instructions.

Selection

Warning

1. This product is intended to be used with general factory automation (FA) equipment.

If considering using the product for other applications (especially those stipulated on Safety Instructions), please consult SMC beforehand.

2. Use this product within the specified voltage and temperature range.

Using outside of the specified voltage can cause a malfunction, damage, electrical shock, or fire.

3. This product is not explosion-protected.

Never use this product in locations where the explosion of dust is likely to occur or flammable or explosive gases are used. This can cause a fire.

Caution

1. Clean specification is not available with this product.

When using in a clean room environment, confirm the required cleanliness before use. Fine particles are generated due to wear of emitters and motor sliding during operation.

Mounting

Warning

1. Reserve enough space for maintenance and wiring.

Install the product and cables taking into consideration the removal of the power supply connector and emitter maintenance. The cable bending should not be less than the minimum bending radius so that stress is not applied to the power supply connector. If the cable is bent in an acute angle or load is applied to the cable successively, it may cause a malfunction, broken wire or fire.

2. Mount this product on a plane surface.

Mounting on an uneven surface will apply excess force to the frame or case, which leads to damage or failure. Do not drop the product or subject it to a strong impact. This may cause an injury or accident.

3. Avoid using in a place where noise (electromagnetic wave and surge) is generated.

If the product is used in an environment where noise is generated, it may lead to deterioration or damage of the internal elements. Take measures to prevent noise at its source and avoid power and signal lines from coming into close contact.

4. Use the correct tightening torque.

If the screws are tightened in excess of the specified torque range, it may damage the mounting screws, mounting brackets, etc. If the tightening torque is insufficient, the mounting screws and brackets may become loose.

5. Do not apply tape or stickers to the product body.

If a tape or seal contains any conductive adhesive or reflective paint, a dielectric phenomenon may occur due to the generated ions, resulting in electrostatic charge or electric leakage. Avoid using such tape and seals as it will not only cause difficulties in maintaining the performance of the product, but may also result in the failure of the product.

6. Ensure the power supply is removed before installing and adjusting the product.

Mounting

Caution

1. Provide sufficient space on the air intake side of this product.

This product ventilates with a fan motor. If there are obstacles such as a wall on the air suction side of the product, the ventilation will be obstructed, decreasing the performance. Install the ionizer so that the air suction side of the product is at least 20 mm (for IZF10, IZF10R, IZF21) or 30 mm (for IZF31) away from any obstacles.

2. Make sure to confirm the effect of static neutralization after installation.

The effects vary depending on the ambient conditions, operating conditions, etc. After installation, verify the effects of static neutralization.

3. When installing ionizers which operate in DC mode (one polarity, positive or negative) close together, they should be positioned at least 2 m away from each other. (IZF21, 31)

When an ionizer is used close to the ionizer which operates in DC mode, separate them by at least 2 m. The offset voltage (ion balance) may not be adjusted by the built-in sensor due to the ions discharged from the ionizer which operates in DC mode.

4. Do not apply an excessive force to the finger guard.

If an excessive external force is applied to the finger guard (including the filter holder) on the air suction side of the product, it may be broken. Do not apply an external force of 50 N or more to the finger guard.

Wiring

Warning

1. Before wiring, ensure that the power supply capacity is larger than the specification and that the voltage is within the specification.

2. To maintain product performance, the power supply shall be UL listed Class 2 certified by National Electric Code (NEC) or evaluated as a limited power source provided by UL60950.

3. Ground the F.G. wire with 100 Ω or less according to the instructions in this catalog. An incomplete ground or no grounding not only prevents the performance of the product from being maintained, but may also cause failure or damage of the product, or electric shock to the human body.

4. Wiring (including insertion and removal of the power supply connector) should never be carried out with the power supply ON.

5. Ensure the safety of wiring and surrounding conditions before supplying power.

6. Do not connect or disconnect the connectors (including power source) while the power is supplied. Failure to follow this procedure may cause product malfunction.

7. If the ionizer wiring and high power lines are routed together, this product may malfunction due to noise. Therefore, use a separate wiring route for this product.

8. Confirm that the wiring is correct before operation. Incorrect wiring will lead to product damage or malfunction.



IZF Series

Specific Product Precautions 2

Be sure to read this before handling the products.
Refer to the back cover for safety instructions.

Operating Environment / Storage Environment

Warning

- 1. Keep within the specified ambient temperature range.**

The specified ambient temperature range for ionizer is 0 to 50°C, and for AC adapter is 0 to 40°C. Avoid sudden temperature changes even within specified ambient temperature range, as it may cause condensation.
- 2. Do not use this product in an enclosed space.**

This product utilizes a corona discharge phenomenon. Do not use the product in an enclosed space as ozone and nitrogen oxides exist in such places, even though in marginal quantities.
- 3. Environments to avoid**

Never use or store under the following conditions. These may cause a failure, fire, etc.

 - a. Where the ambient temperature exceeds the operating temperature range.
 - b. Where the ambient humidity exceeds the operating humidity range.
 - c. Areas where abrupt temperature changes may cause condensation.
 - d. Areas where corrosive gas, flammable gas or other volatile flammable substances are stored.
 - e. Areas where the product may be exposed to conductive powder such as iron powder or dust, oil mist, salt, organic solvent, machining chips, particles or cutting oil (including water and any liquids), etc.
 - f. Paths of direct air flow, such as air conditioners.
 - g. Enclosed or poorly ventilated areas.
 - h. Locations that are exposed to direct sunlight or heat radiation.
 - i. Areas where strong electromagnetic noise is generated, such as strong electrical and magnetic fields or supply voltage spikes.
 - j. Areas where the product is exposed to static electricity discharge.
 - k. Locations where strong high frequency is generated.
 - l. Locations that are subject to potential lightning strikes.
 - m. In an area where the product may receive direct impact or vibration.
 - n. Areas where the product may be subjected to forces or weight that could cause physical deformation.
- 4. The product does not incorporate protection against lightning surges. (IZF10, IZF10R)**
- 5. Effects on implantable medical devices**

The electromagnetic waves emitted from this product may interfere with implantable medical devices such as cardiac pacemakers and cardioverter defibrillators, resulting in the malfunction of the medical device or other adverse effects. Please use extreme caution when operating equipment which may have an adverse effect on your implantable medical device. Be sure to thoroughly read the precautions stated in the catalog, operation manual, etc., of your implantable medical device, or contact the manufacturer directly for further details on what types of equipment need to be avoided.

Maintenance

Warning

- 1. Perform maintenance regularly and clean the emitters.**

It is recommended to perform maintenance every week or when the maintenance warning function turns ON. Check regularly if the product is operating with undetected failures or not. The maintenance must be performed by an operator who has sufficient knowledge and experience. If the product is used for an extended period with dust present on the emitters, the product performance will be reduced. If the emitter becomes worn and the product performance is not restored after cleaning, replace the cartridge case.
- 2. Cleaning or replacing the emitters should never be performed while the power is supplied to the product.**

The fan will rotate due to inertial force even when the power supply is OFF. Confirm that the fan does not move before performing cleaning or replacing the emitters. Never perform cleaning or replacing the emitters when the fan motor is rotating. The fan rotation may cause injury. Never touch the electrodes with the power supplied to this product. Electric shock may cause injury.
- 3. Do not disassemble or modify the product.**

Disassembling or modifying the product may cause accidents such as electric shock, failure or fire. The product will not be guaranteed if it is disassembled and/or modified.
- 4. Do not operate the product with wet hands.**

Never operate the product with wet hands. It may cause electric shock or other accidents.

Danger High Voltage

This product contains a high voltage generation circuit. When performing maintenance inspection, be sure to confirm that the power supply to the ionizer is turned off. Never disassemble or modify the ionizer, as this may not only impair the product's functionality but could cause an electric shock or electric leakage.

Caution

- 1. Do not drop, hit or apply excessive shock (100 m/s² or more) to the product when handling it.**

Even if the body appears undamaged, the internal components may be damaged, leading to a malfunction.

Safety Instructions

These safety instructions are intended to prevent hazardous situations and/or equipment damage. These instructions indicate the level of potential hazard with the labels of “**Caution**,” “**Warning**” or “**Danger**.” They are all important notes for safety and must be followed in addition to International Standards (ISO/IEC)*1), and other safety regulations.

 **Caution:** **Caution** indicates a hazard with a low level of risk which, if not avoided, could result in minor or moderate injury.

 **Warning:** **Warning** indicates a hazard with a medium level of risk which, if not avoided, could result in death or serious injury.

 **Danger :** **Danger** indicates a hazard with a high level of risk which, if not avoided, will result in death or serious injury.

*1) ISO 4414: Pneumatic fluid power – General rules relating to systems.
ISO 4413: Hydraulic fluid power – General rules relating to systems.
IEC 60204-1: Safety of machinery – Electrical equipment of machines.
(Part 1: General requirements)
ISO 10218-1: Manipulating industrial robots – Safety.
etc.

Warning

1. The compatibility of the product is the responsibility of the person who designs the equipment or decides its specifications.

Since the product specified here is used under various operating conditions, its compatibility with specific equipment must be decided by the person who designs the equipment or decides its specifications based on necessary analysis and test results. The expected performance and safety assurance of the equipment will be the responsibility of the person who has determined its compatibility with the product. This person should also continuously review all specifications of the product referring to its latest catalog information, with a view to giving due consideration to any possibility of equipment failure when configuring the equipment.

2. Only personnel with appropriate training should operate machinery and equipment.

The product specified here may become unsafe if handled incorrectly. The assembly, operation and maintenance of machines or equipment including our products must be performed by an operator who is appropriately trained and experienced.

3. Do not service or attempt to remove product and machinery/equipment until safety is confirmed.

1. The inspection and maintenance of machinery/equipment should only be performed after measures to prevent falling or runaway of the driven objects have been confirmed.
2. When the product is to be removed, confirm that the safety measures as mentioned above are implemented and the power from any appropriate source is cut, and read and understand the specific product precautions of all relevant products carefully.
3. Before machinery/equipment is restarted, take measures to prevent unexpected operation and malfunction.

4. Contact SMC beforehand and take special consideration of safety measures if the product is to be used in any of the following conditions.

1. Conditions and environments outside of the given specifications, or use outdoors or in a place exposed to direct sunlight.
2. Installation on equipment in conjunction with atomic energy, railways, air navigation, space, shipping, vehicles, military, medical treatment, combustion and recreation, or equipment in contact with food and beverages, emergency stop circuits, clutch and brake circuits in press applications, safety equipment or other applications unsuitable for the standard specifications described in the product catalog.
3. An application which could have negative effects on people, property, or animals requiring special safety analysis.
4. Use in an interlock circuit, which requires the provision of double interlock for possible failure by using a mechanical protective function, and periodical checks to confirm proper operation.

Caution

1. The product is provided for use in manufacturing industries.

The product herein described is basically provided for peaceful use in manufacturing industries.
If considering using the product in other industries, consult SMC beforehand and exchange specifications or a contract if necessary.
If anything is unclear, contact your nearest sales branch.

Limited warranty and Disclaimer/ Compliance Requirements

The product used is subject to the following “Limited warranty and Disclaimer” and “Compliance Requirements”.

Read and accept them before using the product.

Limited warranty and Disclaimer

1. The warranty period of the product is 1 year in service or 1.5 years after the product is delivered, whichever is first.*2)
Also, the product may have specified durability, running distance or replacement parts. Please consult your nearest sales branch.
2. For any failure or damage reported within the warranty period which is clearly our responsibility, a replacement product or necessary parts will be provided.
This limited warranty applies only to our product independently, and not to any other damage incurred due to the failure of the product.
3. Prior to using SMC products, please read and understand the warranty terms and disclaimers noted in the specified catalog for the particular products.

*2) Vacuum pads are excluded from this 1 year warranty.

A vacuum pad is a consumable part, so it is warranted for a year after it is delivered.
Also, even within the warranty period, the wear of a product due to the use of the vacuum pad or failure due to the deterioration of rubber material are not covered by the limited warranty.

Compliance Requirements

1. The use of SMC products with production equipment for the manufacture of weapons of mass destruction (WMD) or any other weapon is strictly prohibited.
2. The exports of SMC products or technology from one country to another are governed by the relevant security laws and regulations of the countries involved in the transaction. Prior to the shipment of a SMC product to another country, assure that all local rules governing that export are known and followed.

Caution

SMC products are not intended for use as instruments for legal metrology.

Measurement instruments that SMC manufactures or sells have not been qualified by type approval tests relevant to the metrology (measurement) laws of each country. Therefore, SMC products cannot be used for business or certification ordained by the metrology (measurement) laws of each country.

Revision history

Edition B	* The IZF10R (with flow rate adjustment function) added. * Number of pages from 28 to 32.	US
Edition C	* A rubber cover has been added for the power supply cable/AC adapter. * Information on the effects on implantable medical devices has been added to the specific product precautions.	YQ

Safety Instructions

Be sure to read the “Handling Precautions for SMC Products” (M-E03-3) and “Operation Manual” before use.