

LONG JAW VERNIER CALIPER

Recommended for sheet metal and plate workings

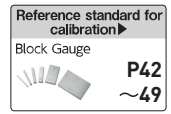

CALIPER

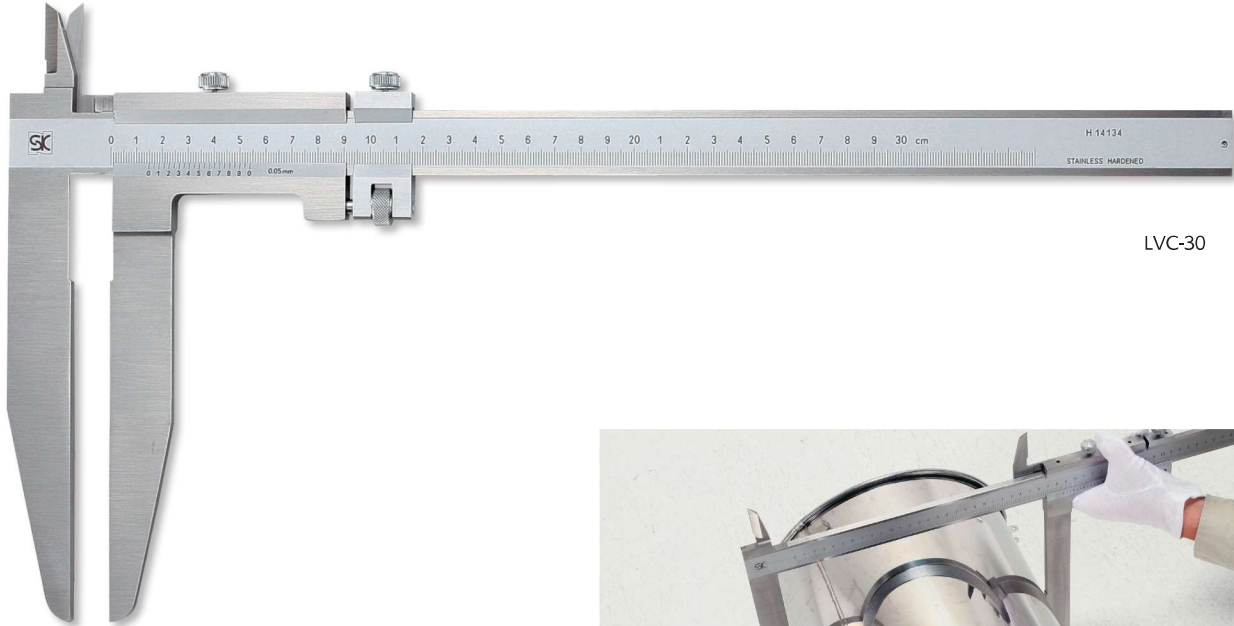

LVC-30



CALIPER

SCRIBING CALIPER

DEPTH GAUGE

HEIGHT GAUGE

DIMENSIONS

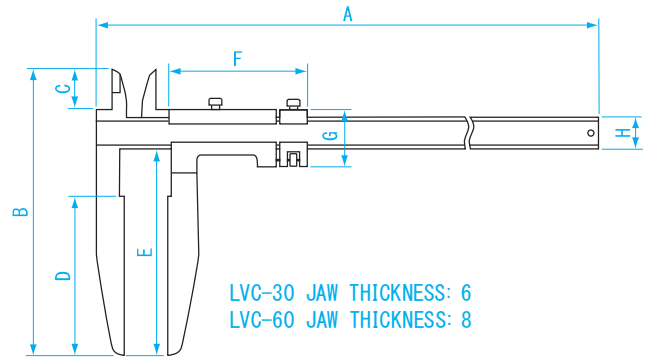

USE

- Outside diameter and inside diameter measurement

MATERIAL

- Stainless steel

FEATURES

- Long jaws for measuring hard-to-reach features
- Suitable for measuring large diameter works

Units: mm

Model No.	A	B	C	D	E	F	G	H
LVC-30	464	238	35	130	170	115	50	25
LVC-60	808	406	45	180	320	140	60	32

※ Accuracy specified for inner most portion of measuring jaw. Instrument error may be slightly higher when using the tip of jaw for performing measurement.

Order No.	Model No.	Measuring Range (mm)	Resolution (mm)	Accuracy * (mm)	Depth Bar (Yes/None)	Weight
151813	LVC-30	300	0.05	± 0.08	None	1.1kg
151814	LVC-60	600		± 0.10		3.1kg