

Relay





CHINT

CHINT



CHINA+TOMORROW= CHINT

“CHIN” indicates “CHINA”, and “T” represents “TOMORROW”, proclaiming its signification-“Tomorrow of China”.



Zhejiang CHINT Electrics Co.,Ltd. (public company, SHA:601877) is the largest-selling low-voltage electrics manufacturers in China. The company mainly engages in the research & development, manufacturing and sales of over 100 series low-voltage products with over 10,000 specification, such as modular Din-rail products, Moulded Case Circuit Breaker, Control products, Relays, Inverters, Soft Starters, Transformers, Automatic Voltage Regulators, Capacitors, Switch Disconnections, etc. and provides integrated electrical system solution for the industries of electric power, machinery, building, communication, HVAC, metallurgy, petrochemical, railway and etc.



With its worldwide presence of distribution network, CHINT is capable of delivering high quality and professional services for its customers at home and abroad.



CHINT is consistently committed to developing itself into a world-class electric supplier of integrated system solutions in this era of economic globalization. By adhering to the development strategy of “internationalization, High-Technology and Industrialization”, the company has persistently devoted itself to the innovation measures in corporate system, technology, and management with a vision of offering global customers with high-performance, intelligent and energy-saving electric products, technologies and services.





Marketing Network

Chint not only has advanced production equipment, strict quality management and innovative research and development team, but also a worldwide marketing network consisting of 5 international marketing areas, 13 domestic marketing offices, 12 logistics centers, more than 280 specialty stores and more than 1000 sales companies, which are always ready to provide the users with high-quality professional services.





Europe



America



CIS Region



West Asia & Africa



Asia-Pacific



CHINT Electric Systems



Thermal power station



Hydraulic power station



Wind Power station



Solar power station

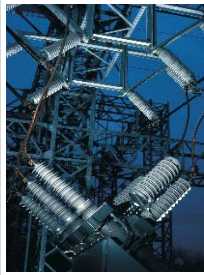

Power Factor Compensation(Outdoor)



HV Capacitor



Automatic Meter Reading System

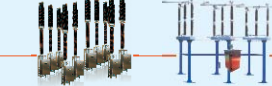

HV SF6 Circuit Breaker



HV Switch-Disconnector



KWH Meter



Microcomputer Protection-Control Device



Prefabricated Substation



Power Transformer



HV Power Transformer



HV Switchgear



HV Switchgear



Power Transformer



GIS



HV Power Capacitor



HV Power Factor Compensation

HV Power Transformer



Outdoor HV AC Switch-Disconnector

HV Power Factor Compensation

HV Power Factor Compensation



HV Current/Voltage Transformer



Surge Arrester

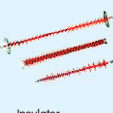

Insulator











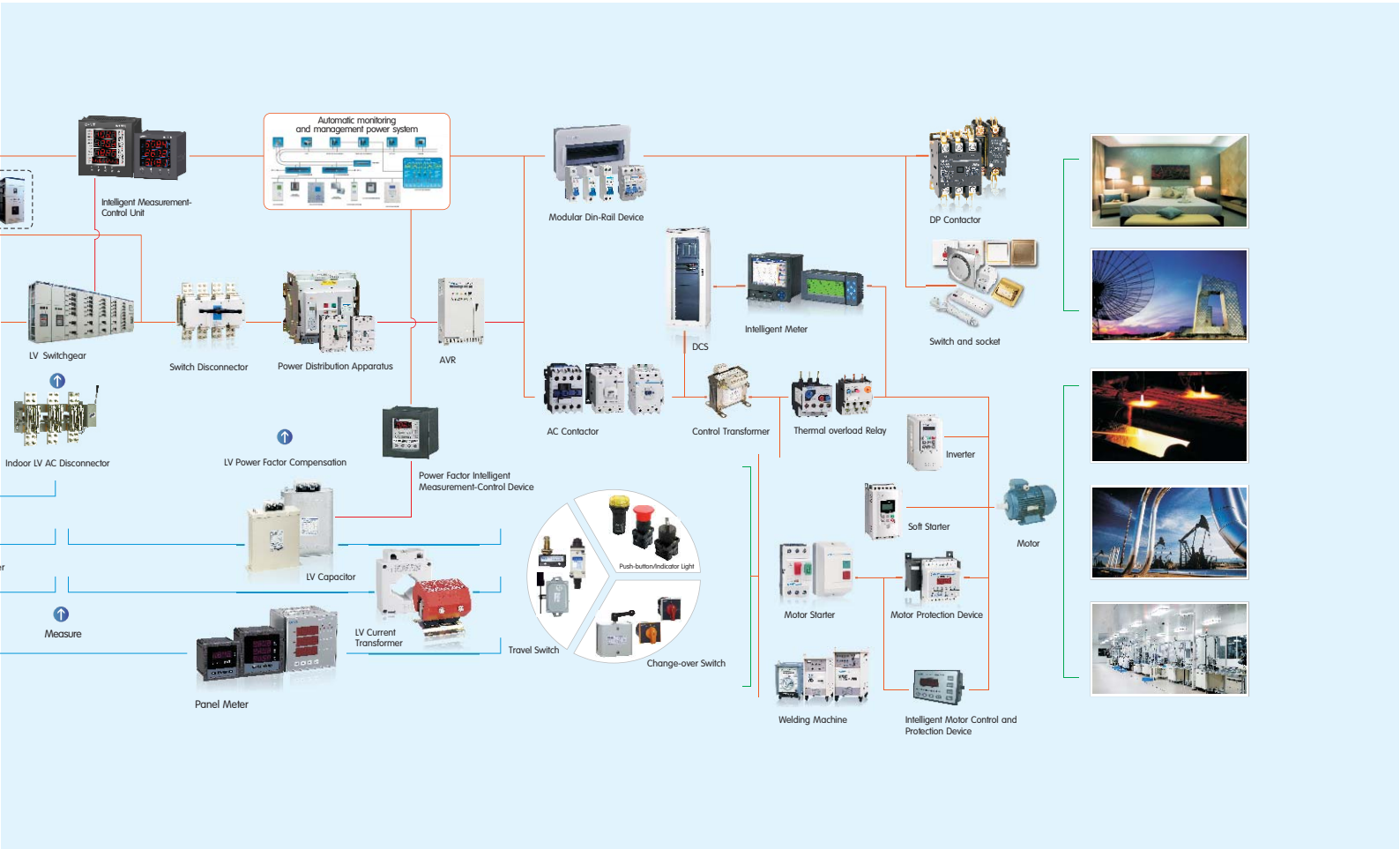







Reactor



KWH Meter



Power of Dedication has transformed CHINT from a simple electric component manufacturer into a leading electric system solution provider, enabling all users from power transmission, distribution and usage sectors to access more reliable, secure, energy-saving, precise, eco-friendly, and intelligent electric products and services. CHINT highly values all personalized demands of electric power, machinery, construction, communications, HVAC, metallurgy, petrochemical, railway, and other industries all the time, and devote itself to facilitating technical innovations and building a green future by providing users with world-class tailor-made electric system solutions.



Relay	
Protection Relay	
 <p>NJB1-YW Liquid Floatless Relay</p> <p>Page 01</p>	 <p>NJB1-X Relay (Three-Phase Unbalance, Phase Sequence, Lack-Phase Protection)</p> <p>Page 02</p>
 <p>NJB1-X1 Relay (phase sequence, phase failure protection)</p> <p>Page 03</p>	 <p>NJB1-Y Single-Phase Voltage Relay</p> <p>Page 04</p>
 <p>NJB1-S Time Delay Relay</p> <p>Page 05</p>	 <p>NJBK2 Motor Protection Relay</p> <p>Page 06</p>
 <p>NJBK5 Motor Controller</p> <p>Page 10</p>	 <p>NJBK5-5 Motor Controller</p> <p>Page 13</p>
 <p>NJBK6 Motor Protection Relay</p> <p>Page 16</p>	 <p>NJBK7 Motor Protection Relay</p> <p>Page 19</p>
 <p>NJBK9 Motor Protection Relay</p> <p>Page 23</p>	 <p>NJXB3 Relay</p> <p>Page 27</p>
 <p>NJYB3 Relay</p> <p>Page 30</p>	 <p>JD-5A(NJBK3) Integrated Motor Protector</p> <p>Page 33</p>
 <p>JD-5 Integrated Motor Protector</p> <p>Page 35</p>	 <p>NJYB1 Phase-Failure and Phase-Sequence Protection Relay</p> <p>Page 38</p>

Relay	
Protection Relay	
 <p>XJ3 Phase-Failure and Phase-Sequence Protective Relay</p> <p>Page 39</p>	
Control Relay	
 <p>NJS6 Time Delay Relay</p> <p>Page 41</p>	 <p>NJS2 Time Delay Relay</p> <p>Page 45</p>
 <p>NJS1 Time Delay Relay</p> <p>Page 49</p>	 <p>NTE8 Time Delay Relay</p> <p>Page 51</p>
 <p>JSS48A Time Delay Relay</p> <p>Page 53</p>	 <p>JSS48B Time Delay Relay</p> <p>Page 55</p>
 <p>JSZ3 Time Delay Relay</p> <p>Page 56</p>	 <p>JSZ4 Time Delay Relay</p> <p>Page 59</p>
 <p>JSZ6 Time Delay Relay</p> <p>Page 60</p>	 <p>NJJ1 Counting Relay</p> <p>Page 61</p>
 <p>NJJ3 Counting Relay</p> <p>Page 65</p>	 <p>NJJ5-J Electronic Counter</p> <p>Page 69</p>
 <p>NJJ5-L Electronic Time Accumulator</p> <p>Page 71</p>	 <p>NJJ6 Counting Relay</p> <p>Page 73</p>
 <p>JDM15G Counting Relay</p> <p>Page 77</p>	 <p>JDM1-48 Counting Relay</p> <p>Page 80</p>

Relay	
Control Relay	
 <p>JDM3 Microminiature Electronic Counter</p> <p>Page 82</p>	 <p>SC3L Microminiature Electronic Time Accumulator</p> <p>Page 84</p>
 <p>NKG3 Time Control Switch</p> <p>Page 86</p>	 <p>NKG2 Time Control Switch</p> <p>Page 88</p>
 <p>NKG1 Time Control Switch</p> <p>Page 90</p>	 <p>KG10D Microcomputer Time Control Switch</p> <p>Page 92</p>
 <p>KG10M Microcomputer Time-Controlling Switch</p> <p>Page 94</p>	 <p>KG316T Microcomputer Time Control Switch</p> <p>Page 95</p>
 <p>NJYW1 Liquid Level Relay</p> <p>Page 97</p>	 <p>JYB-714 Liquid Floatless Relay</p> <p>Page 99</p>
 <p>Time Relay Socket Series</p> <p>Page 101</p>	
General Purpose Relay	
 <p>NJX-13FW Miniature Power Relay</p> <p>Page 103</p>	 <p>JQX-13F Miniature High-power Electromagnetic Relay</p> <p>Page 106</p>
 <p>JZX-22F Miniature Power Relay</p> <p>Page 108</p>	 <p>JQX-10F Miniature Power Relay</p> <p>Page 111</p>
 <p>JTX Miniature Power Relay</p> <p>Page 113</p>	 <p>JMK Miniature Power Relay</p> <p>Page 115</p>

Relay	
General Purpose Relay	
 <p>NJMC1 Pulse Relay</p> <p>Page 117</p>	 <p>Power Relay Socket Series</p> <p>Page 119</p>



NJB1-YW Floatless Relay

1. General

NJB1-YW Floatless Relay is applicable for water level automatic control in industrial facilities & equipments, civil water tower, high cistern, underground conservation pool, etc. The control of automatic water supply or drainage may be achieved by a single operation of the function switch without modifying the user's connecting conditons. This product is not applicable for water level control of flammable and explosive liquid, such as oil, chemical liquid, etc.

2. Type designation

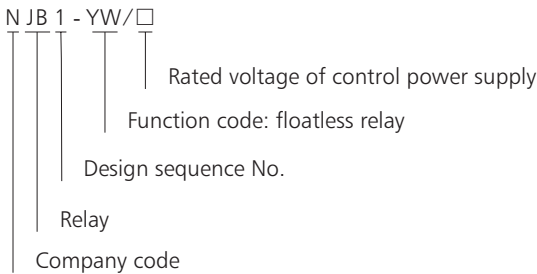

3. Technical data

Type	NJB1-YW
Operating mode	Continuous operating
Contact number	1 Switching
Operating voltage	AC 50Hz/60Hz 36V, 110V, 220V, 380V, (other voltage may be custom made)
Voltage between electrodes	AC9V
Power consumption	Max value about 3VA
Operation resistance	5kΩ~100kΩ(adjustable)
Resetting resistance	250kΩmax
Response time	0.1s~10s(adjustable)
Cable length	Max length 100m
Indication mode	Green LED: power supply indication; red LED:relay operation indication
Ambient temperature	-5℃~+40℃
Installation mode	Equipment or Track Type

4. Operation time-sequence diagram and wiring diagram

NJB1-YW operation time-sequence diagram

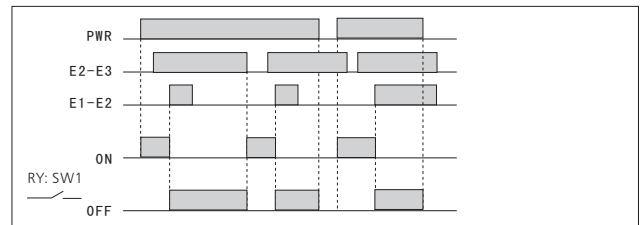

NJB1-YW wiring diagram

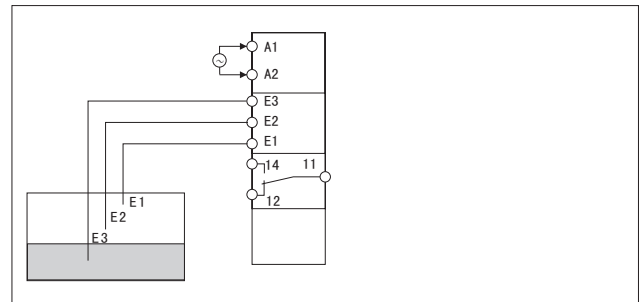

5. Overall and mounting dimensions (mm)

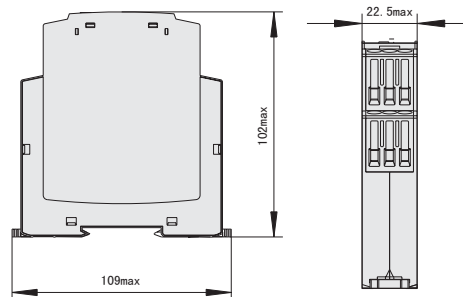



NJB1-X Relay (Three-Phase Unbalance, Phase Sequence, Phase Failure Protection)

1. General

NJB1-X relay (hereinafter called relay) are applied in AC380V~480V control circuits at a frequency of 50Hz/60Hz as protection elements of phase sequence, phase failure and phase unbalance, making or breaking circuits. The relay with the true effective value of three phase AC voltage provides more reliable operating protection. The products meet the requirements of standard IEC 60947-5-1.

2. Type designation

N JB 1 - □ / □

Rated voltage of control power supply

Function code: X: Three-Phase Unbalance, Phase Sequence, Phase Failure Protection.

Design sequence No.

Relay

Company code

3. Technical data

Type	NJB1-X
Operating voltage	Three-phase, three-line mode: 380, 400, 415, 480VAC Three-phase, four-line mode: 220, 230, 240, 277VAC
Three-phase unbalance Operation	Unbalance rate: 2%~22%
Unbalance Operation time	0.1~30s adjustable
Contact number	1 Switching
Contact capacity	3A 230VAC cos φ = 1
Indication mode	Power supply: green LED, delay output: yellow LED, alarm indication: red LED
Ambient temperature	-5°C ~ +40°C
Installation mode	Equipment type or track type

4. Overall and mounting dimensions (mm)

NJB1-X

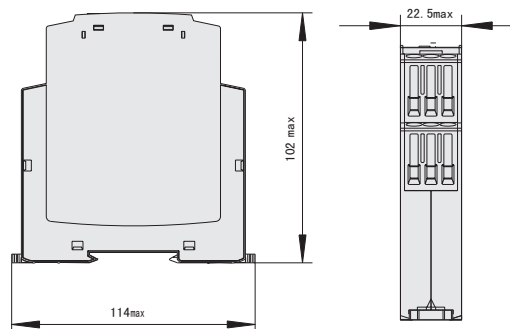

5. Wiring diagram

NJB1-X

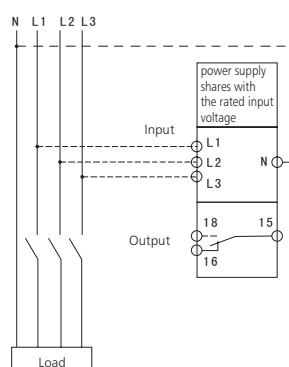



NJB1-X1 Relay (Phase Sequence, Phase Failure Protection)

1. General

NJB1-X1 relay (phase sequence, phase failure protection) is used as an phase sequence and phase failure protection device in control circuits with an AC voltage of 200V~500V and a frequency of 50Hz to make and break the circuit. It cannot monitor the phase failure of motor load. The products meet the requirement of standard IEC 60947-5-1

2. Type designation

N JB 1 - X1



Function code:
X1: phase sequence, phase failure relay

Design sequence No.

Protection and monitoring relay

Company code

3. Operation conditions

- 3.1 Rated operational voltage: AC 200V~500V
- 3.2 Operation time: phase sequence, phase failure $\leq 0.1s$
- 3.3 Contact capacity: U_e/I_e : AC-15 220V/0.75A, 380V/0.47A; I_{th} : 3A
- 3.4 Mounting type: rail type, installation type
- 3.5 Power consumption: $\leq 3VA$
- 3.6 Note: In normal operation, the N/O contact of the relay is closed, the operation indicator is on.

4. Wiring diagram

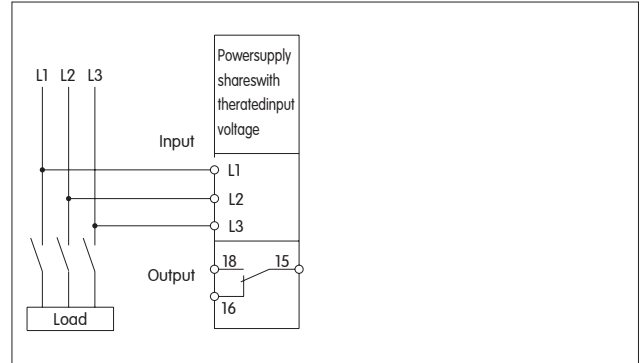

5. Overall and mounting dimensions (mm)

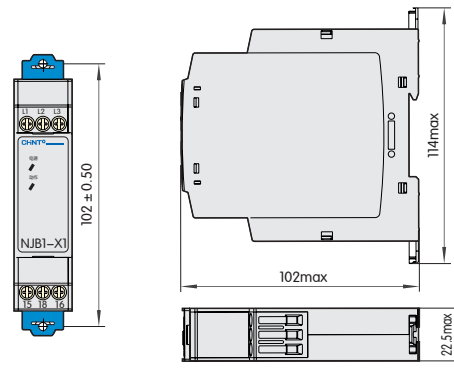



NJB1-Y Single-Phase Voltage Relay

1. General

NJB1-Y single phase voltage relays (hereinafter the relay for short) are applied in AC 220V, 110V, 24V, frequency 50Hz (or 60Hz) and DC 24V control circuits as single phase over-voltage protection or under-voltage protection and indication elements, making or breaking circuits as intended operating values and time.

The product are in compliance with requirements of standard IEC 60947-5-1

2. Type designation

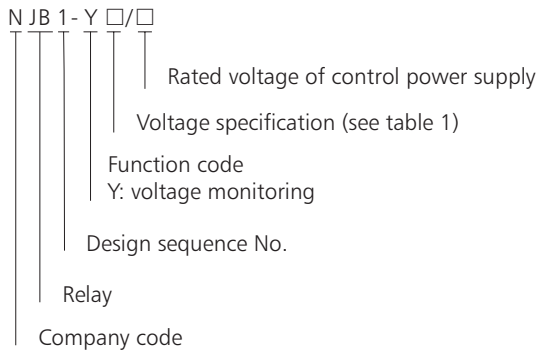

Design Consequence number

Model	Rated operation power supply	Rated input voltage
NJB1-Y1	DC24V	A: COM AC/DC 6mV~60mV B: COM AC/DC 10mV~100mV C: COM AC/DC 30mV~300mV
	AC24V	
	AC110V	
	AC220V	
NJB1-Y2	DC24V	A: COM AC/DC 1V~10V B: COM AC/DC 3V~30V C: COM AC/DC 15V~150V
	AC24V	
	AC110V	
	AC220V	
NJB1-Y3	DC24V	A: COM AC/DC 20V~200V B: COM AC/DC 30V~300V C: COM AC/DC 60V~600V
	AC24V	
	AC110V	
	AC220V	

3. Technical data

Type	NJB1-Y
Protection mode	Over-voltage protection, under-voltage protection
Operating voltage	DC24V; AC220V, AC110V, AC24V, 50/60Hz
Operation Setting Range	10%~100% of max rated input value
Operation time	0.1s~30s adjustable
Repeating precision	±10% of operation value
Time error	±10% of set value
Input frequency	40~500Hz
Contact number	1 Switching
Contact capacity	3A 230VAC cos φ = 1
Mechanical Endurance	≤10,000,000 times
Electrical Endurance	Making 50,000times, breaking 30,000times
Installation mode	Track and Bolts

4. Wiring diagram

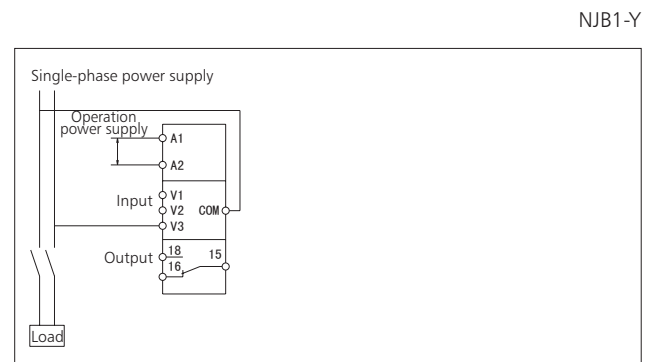

5. Overall and mounting dimensions (mm)

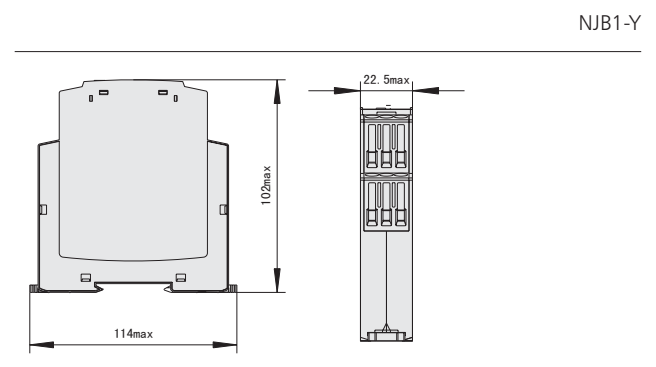



NJB1-S Time Delay Relay

1. General

NJB1-S Series Monitoring Protection Relay is applicable for controlling circuit @ A.C. 50Hz/ 60Hz, up to 380V rated supply voltage and up to D.C.24V supply voltage as monitoring protection element to make or break circuit according to preset value.

NJB1-S time-delay relay is used in controlling circuit as time delay element to make or break circuit according to preset time.

2. Type designation

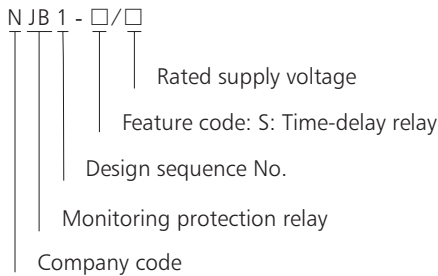

3. Technical data

Type	NJB1-S
Operation mode	Delayed ON operation/Interval operation/Recycle operation
Contact number	Delay 1 Switching
Contact capacity	Ue/Ie:AC-15 220V/0.75A,380V/0.47A,Ith:3A
Operating voltage	AC220V AC380V 50Hz/60Hz (other size may be custom made)
Electrical Endurance	1×10^5
Mechanical Endurance	1×10^6
Delay precision	5%
Ambient temperature	-5°C ~ +40°C
Installation mode	Track mouting
Delay range	Code name: 2 5 10 20 50 100 (time unit: s/min/h, optional) Range: 0.2~2 0.5~5 1~10 2~20 5~50 10~100 12~120 Note: delay range and time unit may be selected through selection switch

4. Wiring diagram

NJB1-S wiring diagram

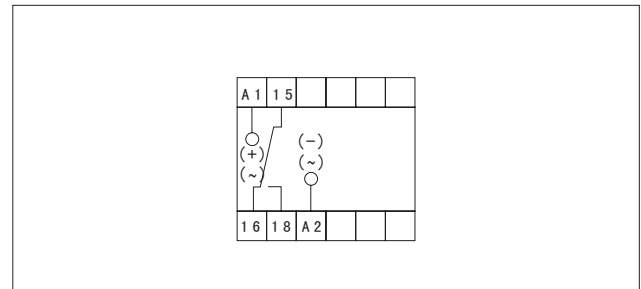

5. Overall and mounting dimensions (mm)

NJB1S

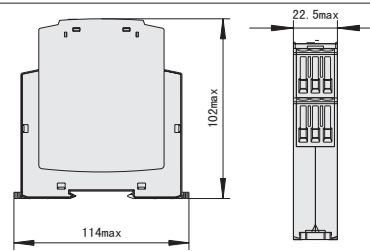

NJB1-S

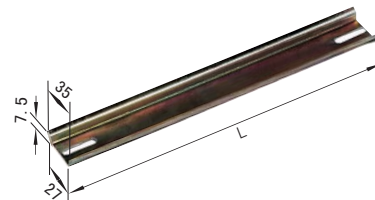

Use TH35-7.5 steel mounting rail for Installation

6. Timing-sequence diagram

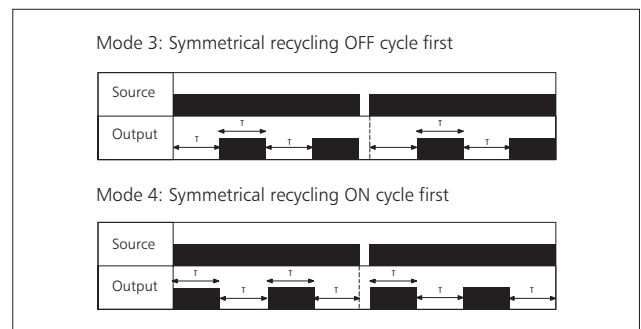
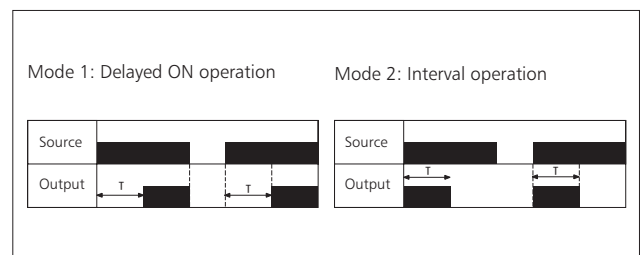



NJBK2 Motor Protection Relay

1. General

NJBK2 series motor protection relay (hereinafter referred to protector as simply) is applicable for overload, locked-rotor, phase-failure, three phase current unbalance, earthing and PTC temperature protection of AC motor @ A.C.50Hz, less than 660V rated operating voltage and 2A ~ 800A rated operating current for its continuous working or discontinuous working.

This product meets the requirements of IEC 60947- 4-1

2. Type designation

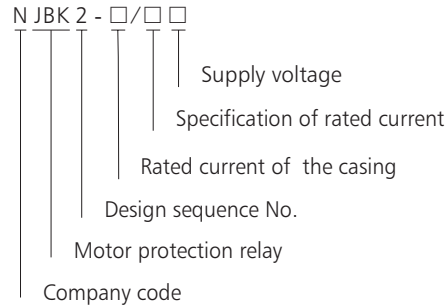

3. Operation conditions

- 3.1 Altitude ≤2000m.
- 3.2 Ambient air temperature -5℃ ~ +40℃, with daily average ≤+35℃.
- 3.3 Atmospheric condition: when the highest temperature is +40℃, relative humidity of air shall be no more than 50%, higher relative humidity shall be allowable at lower temperature. The max monthly average relative humidity of the most humid month shall be not more than 90% and the lowest monthly average temperature of the same month should be no more than +25 ℃, condensed dew on surface of the product due to the change of the temperature should be taken into account.
- 3.4 Pollution Level: Level 3.
- 3.5 Installation Category: III.
- 3.6 Inclination between installation plane and vertical plane shall ≤±5°.
- 3.7 At places without prominence rock, impact and vibration.
- 3.8 At places without explosive risk, without gases that may be corrosive to metal or gases that may cause damage to the insulation, and with little conducting dust
- 3.9 At places where rain & snow proof facilities are equipped with and not being full of steam.

4. Technical data

4.1 Main circuit: rated insulation voltage AC690V, rated frequency 50/60Hz.

Type	Rated current (A)	Setting current range (A)	Suitable motor power (kW)
NJBK2-200/10	10	2~10	1~5
NJBK2-200/50	50	10~50	5~25
NJBK2-200/200	200	40~200	20~100
NJBK2-400/400	400	160~400	80~200
NJBK2-800/800	800	320~800	160~400

4.2 Auxiliary circuit: rated insulation voltage AC380V, rated frequency 50Hz/60Hz, Utility classes, rated operating voltage, rated operating current and conventional heating current.

Utility classes		AC-15	
Rated operating voltage (V)	240		380
Rated operating current (A)	1.5		0.95
Conventional heating current (A)		10	

5. Design features

- 5.1 Equipped with functions of overload, locked-rotor, phase-failure, three-phase unbalance, earthing and PTC temperature protection etc.
- 5.2 Six indicators indicate status of power supply, operation, phase-failure (three phase unbalance), overload, earthing and temperature, respectively. Equipped with function of fault memory.
- 5.3 four kinds of trip class
- 5.4 Digital dial-up settings with high precision.
- 5.5 Three kinds of reset modes: manual reset, remote manual reset and automatic reset

5.6 Installation mode: installation in parts and integral installation. Transformer Installation: bolts installation and Track installation. Relay Installation: Rapid Track installation through meter.

5.7 Equipped with function of six times of current to test [Test by 6 times of the current].

6. Protection features

6.1 Operation characteristics under three-phase balanced-load status

S.N.	Times of setting current	Trip class	Operation time	Test condition	Ambient temperature °C
1	1.05	10A	<2h non-tripping	Start from cold status	
		10			
		20			
		30			
2	1.2	10A	<2h tripping	Start right after Item No.1	20±2
		10			
		20			
3	1.5	10A	<2min	Start right after Item No.1	
		10	<4min		
		20	<8min		
		30	<12min		
4	7.2	10A	2s < tp ≤ 10s	Start from cold status	
		10	4s < tp ≤ 10s		
		20	6s < tp ≤ 20s		
		30	9s < tp ≤ 30s		

6.2 Operation characteristic under phase-failure status

S.N.	Times of setting current		Operation time	Test condition	Ambient temperature °C
	Any two phases	The third phase			
1	1.0	0.9	<2h non-tripping	Start from cold status	20±2
2	0.3~1.0	<Imax×40%	≤5s		
3	0.3~1.0	0	≤5s		

6.3 Tripping feature

NJBK2 current-time characteristic curve

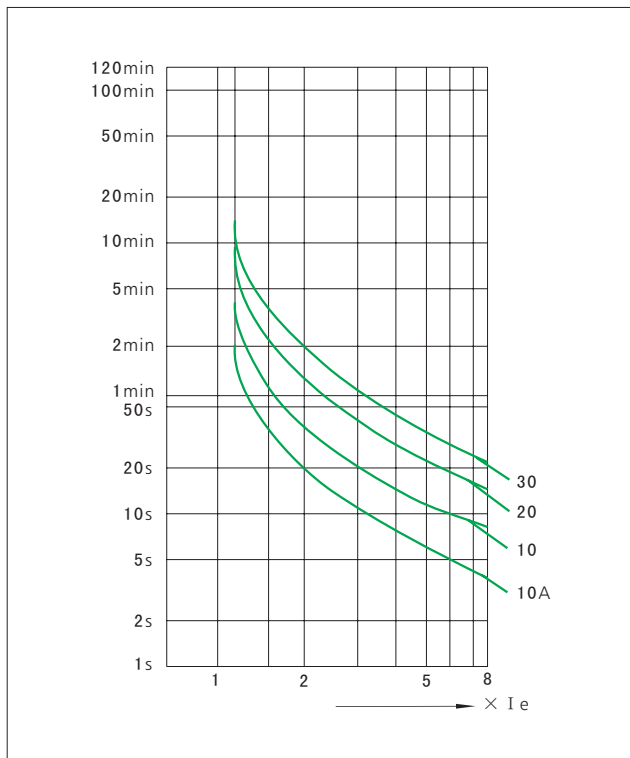

6.4 Performance feature of earthing protection

Zero sequence current (A)	Operation time (s)
≥0.5	≤1

6.5 Protection feature of pre-buried PTC thermistor in motor: PTC thermistor protection is carried out by detecting resistance value of thermistor output from PTC detector pre-buried in stator winding or bearing of motor and taking it as protection condition to judge whether motor is overheating, when PTC reaching reacting resistance value, reacting delay < 1s.

PTC protection

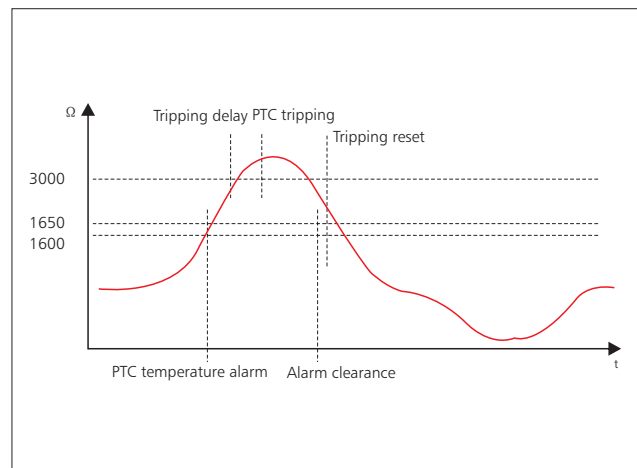

6.6 Reset feature: Manual reset, automatic reset and remote manual reset are available for option. Resetting time varies according to different trip class, among the range of 4min to 12min.

7. Wiring diagram

7.1 Wiring diagram for control power supply @ AC220V/AC230V voltage

Wiring diagram for control power supply @ AC220V/AC230V voltage

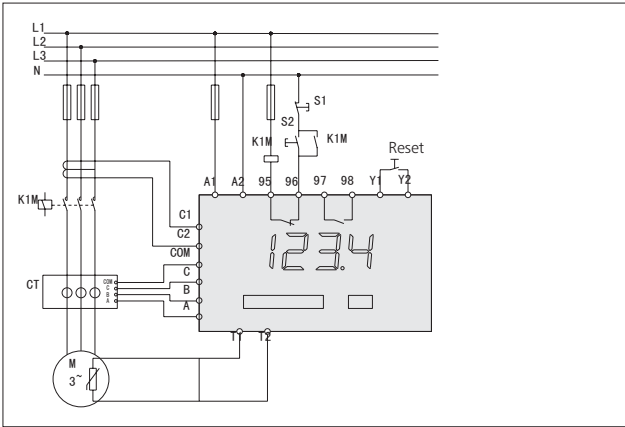

7.2 Wiring diagram for control power supply @ AC380V/AC400V voltage

Wiring diagram for control power supply @ AC380V/AC400V voltage

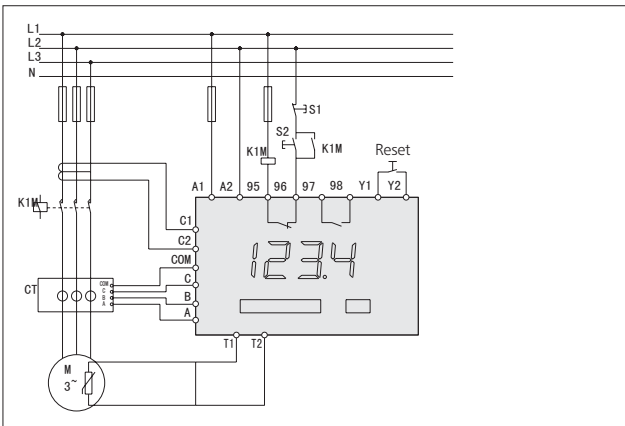

8. Accessory instruction

S.N.	Designation	Quantity	Remarks
1	NJBK2-200 conductive bar	3	It is suggested to be used when main circuit current is within the range of 80A-200A.
2	NJBK2 wire holder	2	Instrument installation
3	NJBK2 clamp	1	Instrument installation

9. Overall and mounting dimensions (mm)

9.1 Overall and Mounting dimensions of NJBK2-200 transformer

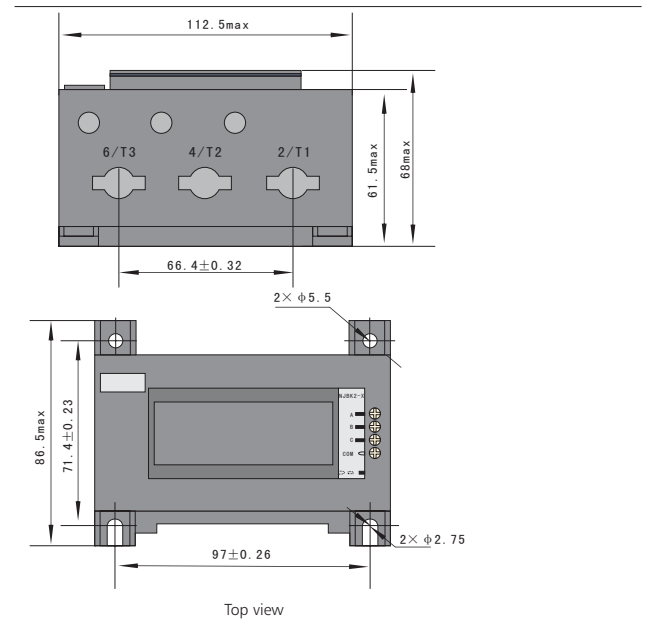

9.2 Overall and Mounting dimensions of NJBK2-200 macropore transformer

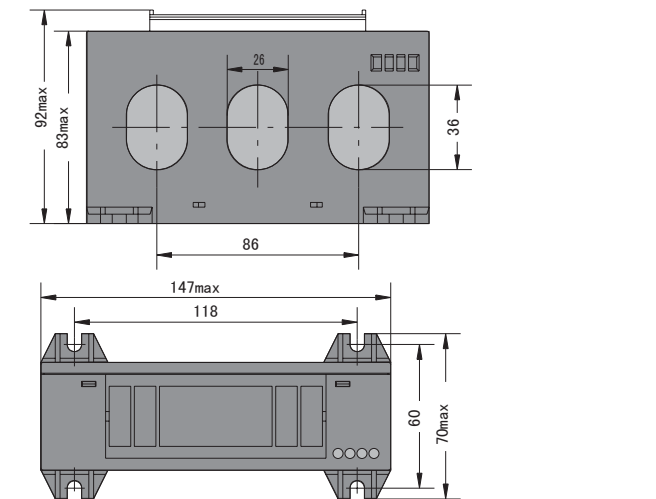

9.3 Overall and Mounting dimensions of NJBK2-400 transformer

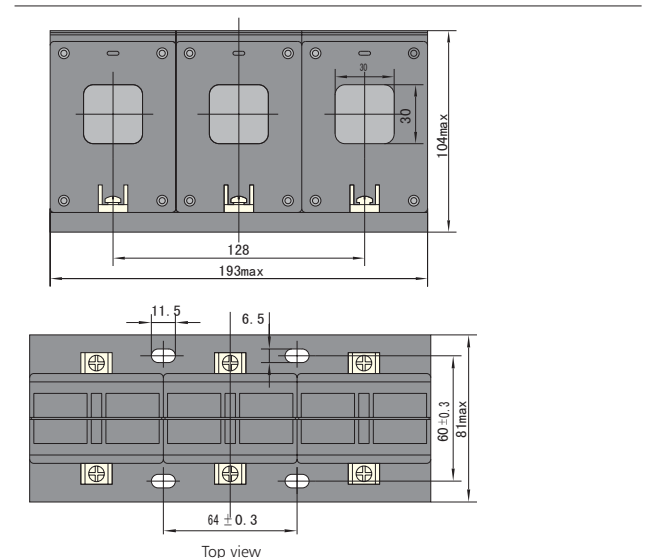

9.4 Overall and Mounting dimensions of NJBK2-800 transformer

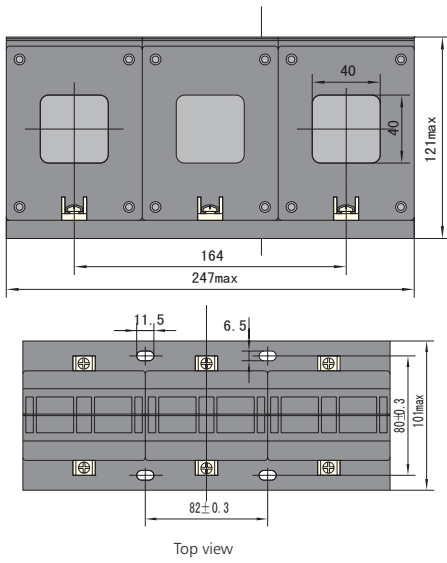

9.7 Overall and Mounting dimensions of relay of protector

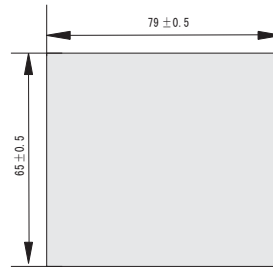

9.5 Overall and Mounting dimensions of module sample

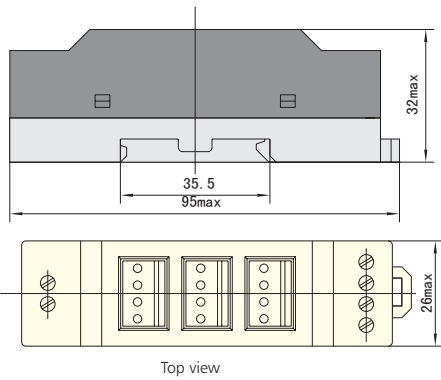

9.6 Overall and Mounting dimensions of relay of protector

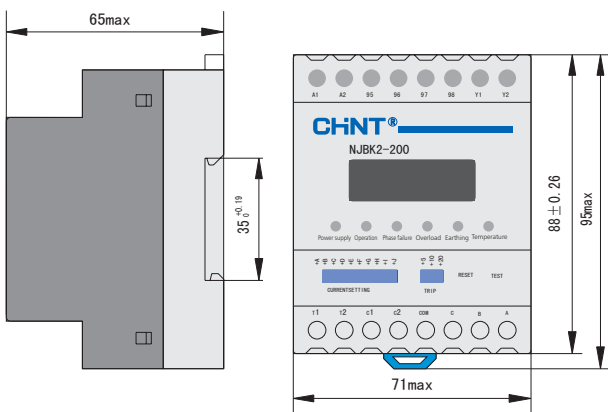

10. Ordering information

10.1 Designation and specification of protector, select control current and voltage (AC220V, AC230V, AC380V, AC400V), setting current range (2A~10A, 10A~50A, 40A~200A, 160A~400A, 320A~800A), accessories (NJBK2-20 conductive bar, NJBK2 wire holder, NJBK2 clamp) according to operating requirements.
10.2 Order Quantity.



NJBK5 Motor Controller

1. General

NJBK5 series motor controller (hereinafter referred to as controller) is mainly used in circuits with a frequency of AC 50Hz (or 60Hz), a rated operational voltage of up to 380V and a rated control power of up to 11kW (current up to 22A) to control the direct start and stop of water pumps or motors, provide motors with overload and phase failure protection, and realize automatic liquid level control for civil water towers and reservoirs.

This product is not applicable to the liquid level control of low-conductivity liquids, such as oil, purified water, inflammable and explosive chemical liquids and high-density sewage.

Standards: IEC 60947-4-1.

2. Type designation

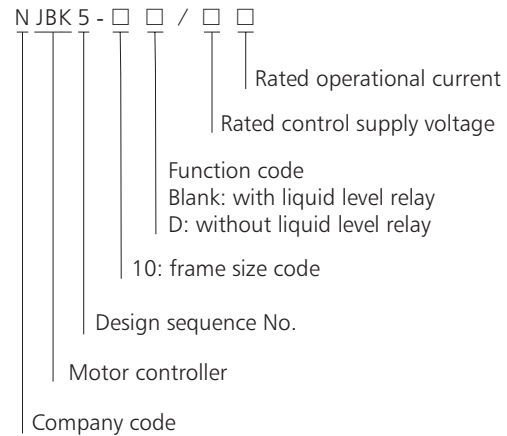

3. Operation conditions

- 3.1 Altitude: the altitude of the mounting location should not exceed 2000m;
- 3.2 Ambient temperature: $-5^{\circ}\text{C} \sim +40^{\circ}\text{C}$, and the average temperature in 24h should not exceed $+35^{\circ}\text{C}$;
- 3.3 Atmospheric conditions: The relative air humidity at the mounting location should not exceed 50% at the maximum temperature of $+40^{\circ}\text{C}$. The relative humidity may be higher at lower temperatures. Special measures should be taken if condensation occurs on the product occasionally due to temperature variation;
- 3.4 Pollution degree: 3;
- 3.5 Mounting category: III;
- 3.6 In places where there is no significant vibration or impact;
- 3.7 In non-explosive media that do not contain a sufficient amount of gas or dust to cause metal corrosion or insulation failure;
- 3.8 In places where rain and snow protection is provided;
- 3.9 The inclination from the vertical plane should not exceed 5° .

Time Relay Socket Series

CZS08C

CZF11A-E (with finger safety protection)



70×50×20(mm)

52×44×31(mm)

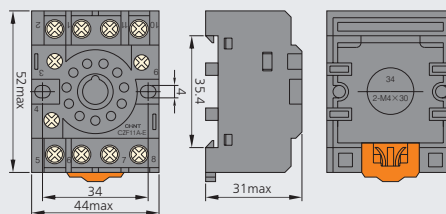
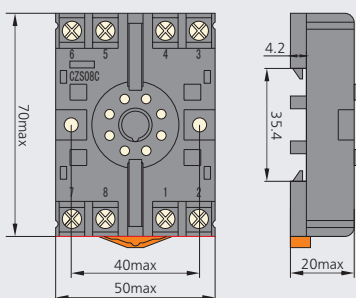

Applicable relay type: JSS48A, JDM1-48, KG10M, JYB-714 and NJS1

Applicable relay type: JS14S device type, and JDM1-14

CZS08G

CZS08X-E (with finger safety protection)



48.8×40×20.1(mm)

72×43.6×21(mm)

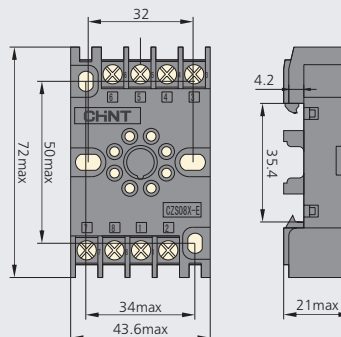
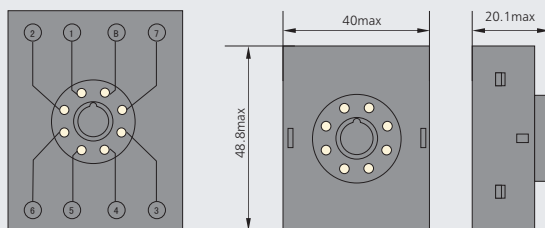

Applicable relay type: JSS48A, NJS1, JDM1-48, KG10M, and JSZ3H-Y

Applicable relay type: JSZ3A, JSZ3C, JSZ3-2/3, JSZ3K, JSZ3R, JSZ3F, and JSZ3Y

CZY08B-01 (wide type, copper strip connection)

CZY14B (copper strip connection)



63×30.5×26(mm)

63×30.5×26(mm)

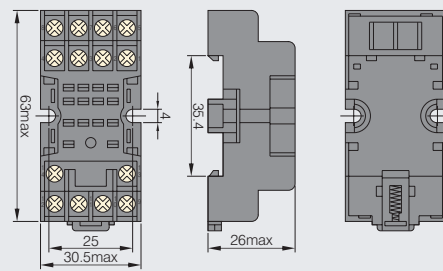
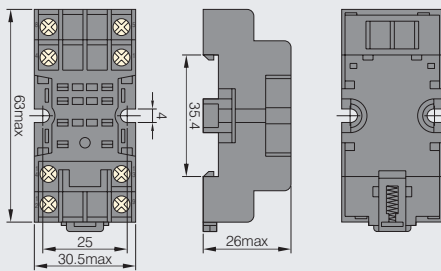

Applicable relay type: JSZ6-2

Applicable relay type: JSZ6-4

CZS08S

CZS11S

FM8858



φ 32.4×36.2(mm)

φ 32.4×36.2(mm)

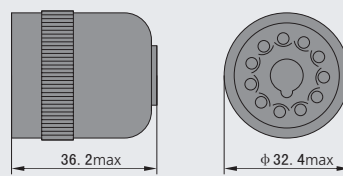
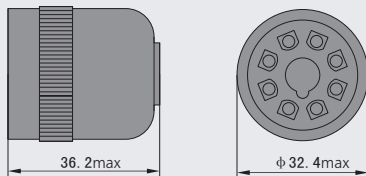

Applicable relay type: JSS48A, JDM1-6, JSZ3H-Y, NJS1

Applicable relay type: JSS48A-11, JDM1-48, NJS1-11

Applicable relay type: JSZ3

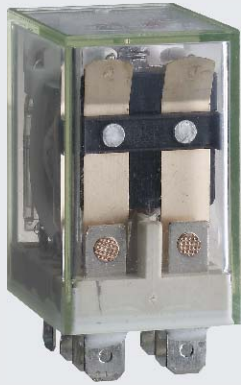

NJX-13FW Miniature Power Relay

1. General

- 1.1 3A, 5A, 10A switching capacity
- 1.2 Wide range of coil ratings
- 1.3 Fully sealed
- 1.4 Certificate: CE, UL

2. Type designation

NJX-13FW (D) / 006 - 2Z 1 1

Installation: 1=top flange type;
2=lateral flange type;
blank=standard type

Termination: 1=PCB 6=Plug-in

Contact arrangement:
2Z=2C(10A); 2ZS=2C(5A);
3ZS=3C; 4ZS=4C
Coil type: ~ = AC; - = DC

Coil voltage : DC: 5V~220V;
AC: 6V~380V

Type:

D=with LED indicator;
B=With LED indicator and surge withstand;
M=With arc suppression cover (only 4C);
Blank=Standard

Series

3. Technical data

Contact Arrangement		2Z	2ZS	3ZS	4ZS
Initial contact resistance	mΩ			100	
Contact material		Silver alloy			
Rated load (resistive)	A (220VAC/28VDC)	10	5	5	3
Max. switching voltage	VAC	250			
	VDC	125			
Max. switching current	A	10	5	5	3
Max. switching power	VA	2200	1100	1100	660
	W	280	140	140	84
Electrical endurance	Cycles(×10 ³)			300	
Machanical endurance	Cycles(×10 ⁶)			10	

4. Coil specification

AC

Rated voltage	Holding voltage	Must drop-out voltage	Operating range	Power consumption
6	80%Un	20%Un	(80%~110%) Un	1.2VA
12				
24				
36				
48				
110				
127				
220				
230				
380				

DC

Rated voltage	Holding voltage	Must drop-out voltage	Operating range	Power consumption
5	75%Un	10%Un	(75%~110%) Un	0.9W
6				
12				
24				
36				
48				
110				
127				
220				



5. Characteristics

Insulation resistance(at 500VDC)		MΩ	100
Dielectric strength	Between coil & contacts		1500VAC
	Between open contacts		1000VAC
Operation time		ms	≤25
Release time		ms	≤25
Shock resistance		m/s ²	100
Vibration			10~55Hz,1mm double amplitude
Ambient temperature range		°C	-30~+60
Termination			Plug-in, PCB
Dimension		mm	27.5×21.5×35.5

6. Overall and mounting dimensions (mm)

Internal connection	2Z	2ZS	3ZS	4ZS
Standard type				
with indicator				
with indicator and diode				
PCB mounting holes				

Dimensions	2Z	2ZS	3ZS	4ZS
Plug-in type				
PCB type				

Installation	2Z	2ZS	3ZS	4ZS
Top flange type				
Lateral flange type				



JQX-13F Miniature High-power Electromagnetic relay

1. General

Contact switching capability of 10A; a complete range of AC/DC specifications; enclosed in transparent dust cover, a variety of mounting types; various sockets available;

Specifications with state indicators available; certification: CQC 03001003918, UL E205607, CE; models of the same type: LY2(N), HH62P(-L).



2. Normal operating conditions and mounting conditions

Temperature range	-30℃~+60℃
Relative humidity	+40℃ return 90%
Atmospheric pressure	86kPa~106kPa
Working position	Any

3. Technical data

3.1 Contact data

Contact form	2Z(C)
Initial contact resistance	100mΩ
Contact material	Silver alloy
Contact load (resistive)	10A/220VAC、10A/28VDC
Max. switching voltage	250VAC/125VDC
Max. switching current	10A
Max. switching power	2200VA 280W
Electrical life (times)	1×10 ⁵
Mechanical life (times)	1×10 ⁷

3.2 Characteristics data

Insulation resistance	100MΩ(500VDC)	
Dielectric strength	Between coil & yoke, between different groups of contacts	1500VAC
	Between open contacts	1000VAC
Operation time	≤25ms	
Release time	≤25ms	
Shock (resistance)	Acceleration: 100m/s ² , pulse duration: 11ms	
Vibration	1mm double amplitude, 10~55Hz	
Outlet terminal type	Plug-in type, PCB type	
Overall dimensions (mm)	27.5×21.5×35.5	

3.3 Coil data

Rate power consumption	0.9W、1.2VA
Pick-up voltage	DC: ≤75% rated voltage; AC: ≤80% rated voltage
Release voltage	DC: ≥10% rated voltage; AC: ≥20% rated voltage
Max. voltage	110% Rated voltage

3.4 Specification data

Rated voltage	Operation voltage VDC(≤)	Release voltage VDC(≥)	Coil resistance Ω ±10%
5	3.75	0.5	28
6	4.5	0.6	44
12	9.0	1.2	160
24	18.0	2.4	640
36	27.0	3.6	1440
48	36.0	4.8	2560
110	82.5	11.0	14500
127	95.3	12.7	17000
220	165.0	22.0	39000

Rated voltage	Operation voltage VDC(≤)	Release voltage VDC(≥)	Coil resistance Ω ±10%
6	4.8	1.2	10.5
12	9.6	2.4	44
24	19.2	4.8	180
36	28.8	7.2	380
48	38.4	9.6	650
110	88.0	22	3670
127	101.6	25.4	4100
220	176.0	44	14500
380	304.0	76	39000

4. Matching socket (optional)

Relay model	JQX-13F(D)/ZZ			
Model of matching socket	CZT08A-01	CZT08A-02	CZT08B-01	CZT08B-01E
Overall dimensions of socket (mm)	72×30×31	72×23×31	68×30×28	68×30×28
Type of socket lead	Screw terminal (installation type, rail type)			

5. Overall and mounting dimensions (mm)

Connection diagram (bottom view) (2Z)

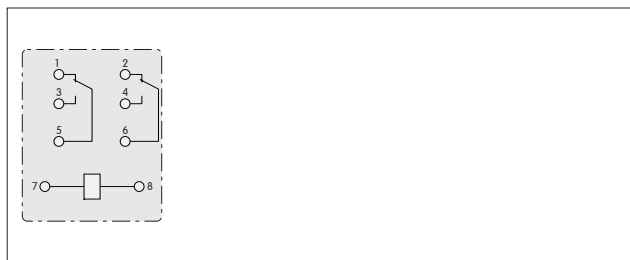

Connection diagram (bottom view) 2Z(D)



Connection diagram (bottom view) 2Z(B)



PCB opening drawing (2Z)

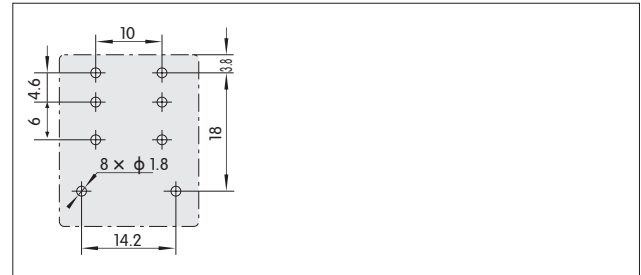

Outline drawing (plug-in type)

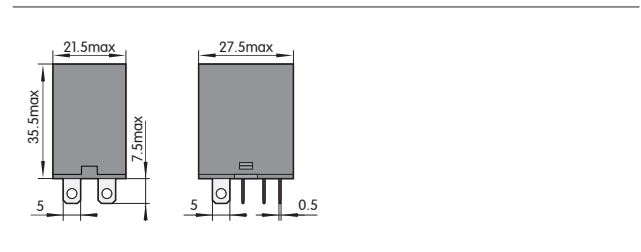

Outline drawing (PCB type)

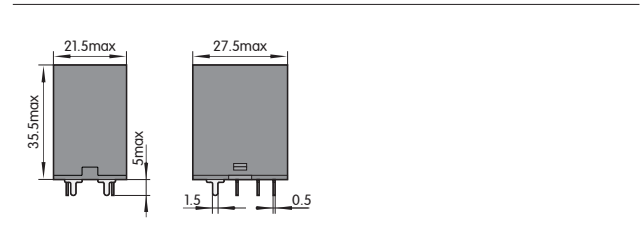

Outline drawing (lateral flange type)

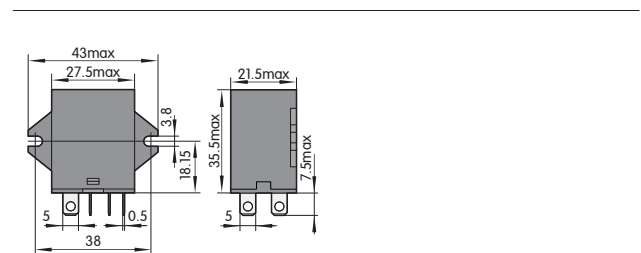

Outline drawing (top flange type)

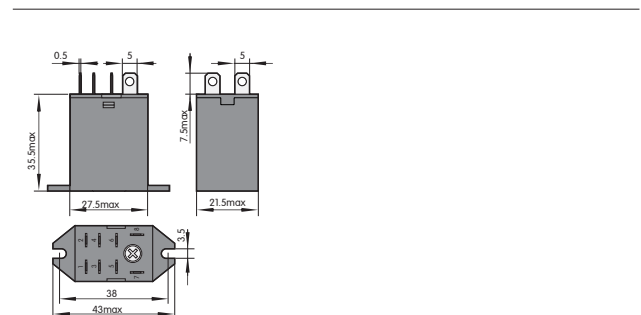



JZX-22F Miniature Power Relay

1. General

- 1.1 3A, 5A switching current
- 1.2 Various sockets available
- 1.3 With indicator to be selected
- 1.4 Full range of AC and DC coil
- 1.5 Certificate: CE.

2. Type designation

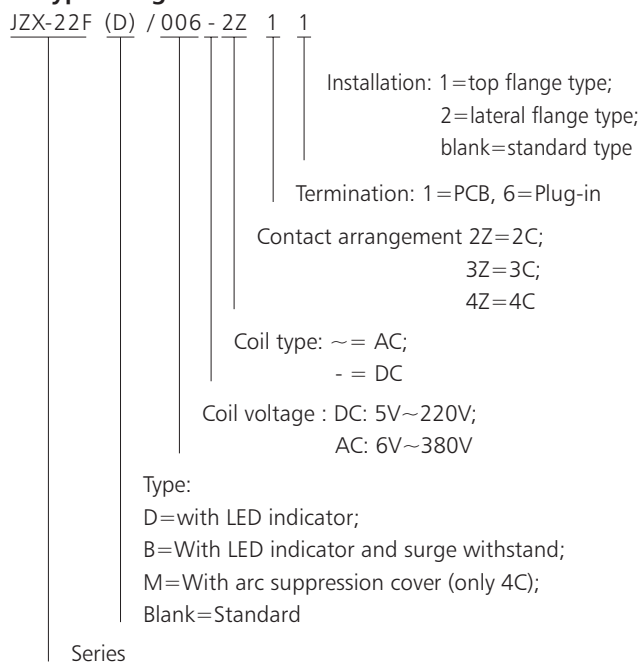

3. Technical data

Contact Arrangement		2C	3C	4C
Initial contact resistance	m Ω	100		
Contact material		Silver alloy		
Rated load(resistive)		5A/220VAC	3A/220VAC	
		5A/28VDC	3A/28VDC	
MAX. switching voltage	VAC	250		
	VDC	125		
MAX. switching current	A	5	3	
	VA	1100VA	660VA	
Max. switching capacity	W	140	84	
Electrical endurance	Cycles(× 10 ³)	100		
Machanical endurance	Cycles(× 10 ⁶)	10		

4. Coil specification

AC

Rated voltage	Holding voltage	Must drop-out voltage	Operating range	Power consumption
6	80%Un	20%Un	(80%~110%)Un	1.2VA
12				
24				
36				
48				
110				
127				
220				
230				
380				



DC

Rated voltage	Holding voltage	Must drop-out voltage	Operating range	Power consumption
5	75%Un	10%Un	(75%~110%) Un	0.9W
6				
12				
24				
36				
48				
110				
127				
220				

5. Characteristics

Insulation resistance(at 500VDC)		MΩ	100
Dielectric strength	Between coil & contacts		1500VAC
	Between open contacts		1000VAC
Operation time		ms	≤25
Release time		ms	≤25
Shock resistance		m/s ²	100
Vibration			10~55Hz, 1mm double amplitude
Humidity			90% RH at +40℃
Ambient temperature range		℃	-30~+55
Termination			Plug-in, PCB
Dimension		mm	27.5×21.5×35.5

6. Overall mounting dimensions (mm)

Internal connection(bottom view)

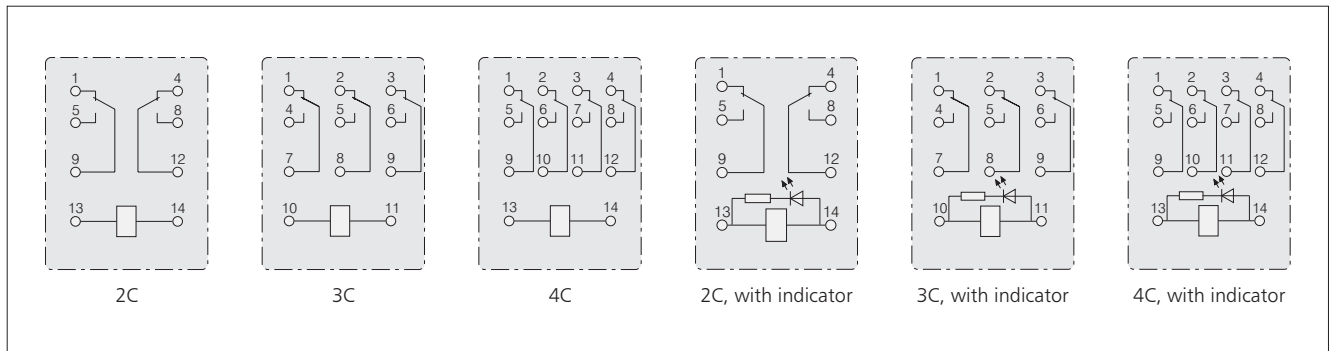

Internal connection(bottom view)

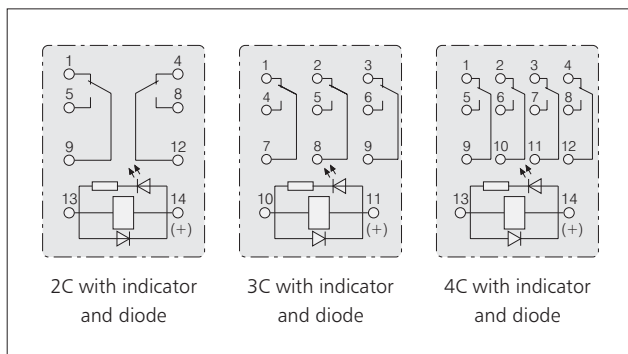

PCB mounting poles

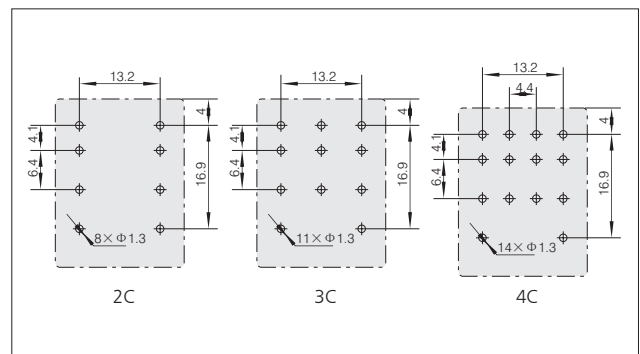

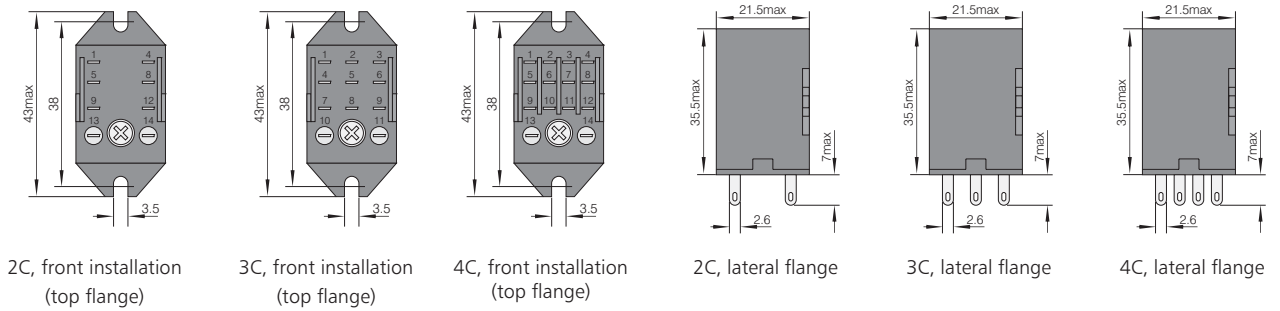
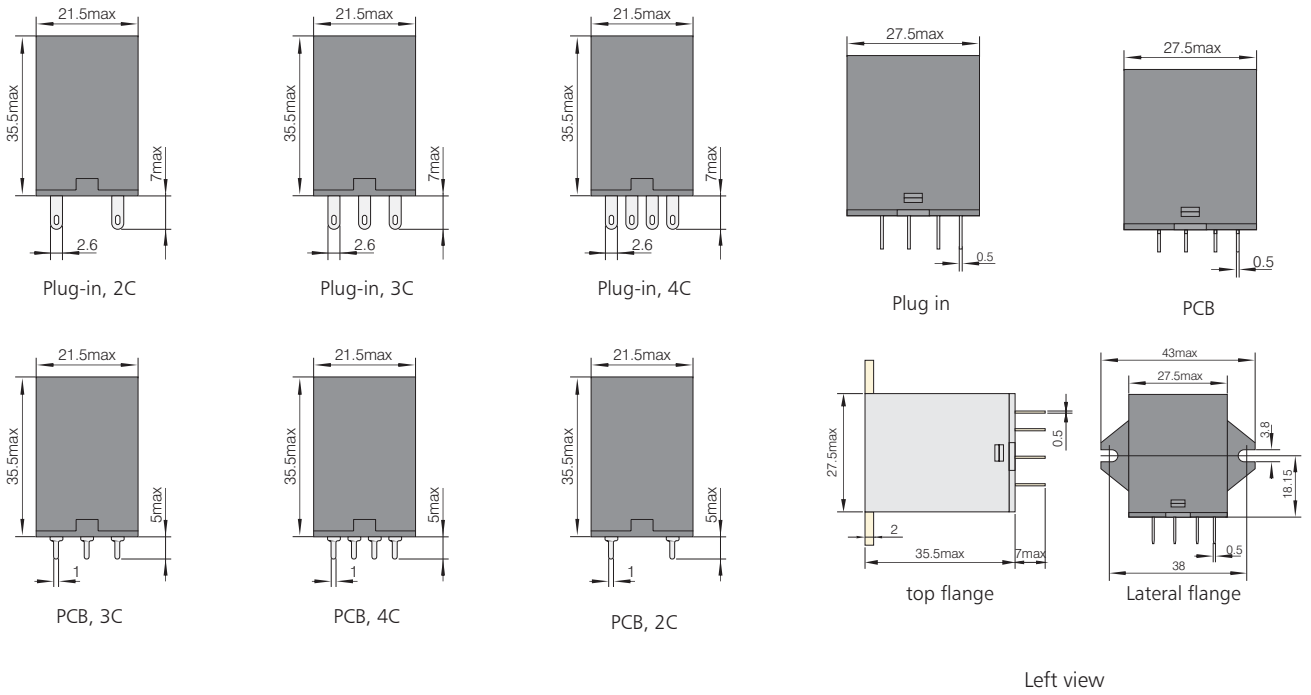

4 Technical data

4.1 Main data and technical characteristics

Type	Conventional heating current (A)	Max. rated power (kW)		Model of matching AC contactor	Model of matching motor protector	Setting current range (A)	Number of turns of protector (turn)
		AC-3					
		380V	220V				
NJBK5-10 0.72A~2.4A	2.4	1.1	0.55	CJX2-1210	JD-8/0.5A~5A	0.72~2.4	5
NJBK5-10D 0.72A~2.4A							
NJBK5-10 3.5A~11A	12	5.5	3	CJX2-1210	JD-8/2A~20A	3.5~11	1
NJBK5-10D 3.5A~11A							
NJBK5-10 10A~16A	16	7.5	4	CJX2-1810	JD-8/2A~20A	10~16	1
NJBK5-10D 10A~16A							
NJBK5-10 20A~25A	25	11	5.5	CJX2-2510	JD-8/20A~80A	20~25	1
NJBK5-10D 20A~25A							

4.2 Rated control supply voltage Us: AC220V, AC380V.

4.3 Degree of protection of enclosure: IP55.

4.4 Protection characteristics of the controller

4.4.1 Phase failure protection characteristics of the controller: In case of failure of any phase of the three-phase main circuit passing through the center hole of the motor comprehensive protector in the controller, the motor comprehensive protector operates for a period of $\leq 5s$.

4.4.2 Overload protection characteristics of the controller under balanced three-phase load.

No.	Setting current multiple	Operation time			Starting conditions
1	1.05	No operation within 2h			Cold state start
2	1.2	Operation within 2h			Start after No.1
3	1.5	Tripping class	30	$\leq 12min$	Start after applying a 1.0 times setting current for 2h
4	7.2	Tripping class	30	$9s < T_p \leq 30s$	Cold state start

4.5 Down-lead distance of liquid level control electrode: 200m max.

4.6 Mounting type: installation type.

5. Features

The controller consists of a CJX2 series AC contactor, a JD-8 series motor comprehensive protector and an NJB1-YW1 liquid level relay in a protective enclosure and is divided into two types, with liquid level relay and without liquid level relay. Products with liquid level relay are used to control the start and stop and automatic pumping and drainage of water pumps and provide overload and phase failure protection. Products without liquid level relay are used to control the start and stop of motors and provide overload and phase failure protection.

Setting of the motor comprehensive protector in the controller is required before it is connected and put into use.

6. Wiring diagram

a. Connection diagram of NJBK5-10 in case both the control circuit voltage and the main circuit voltage are AC380V

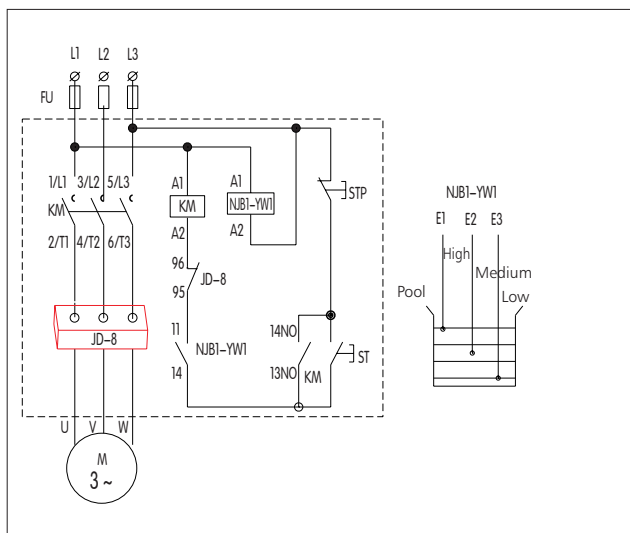

b. Connection diagram of NJBK5-10 in case the main circuit voltage is AC380V and the control circuit voltage is AC220V

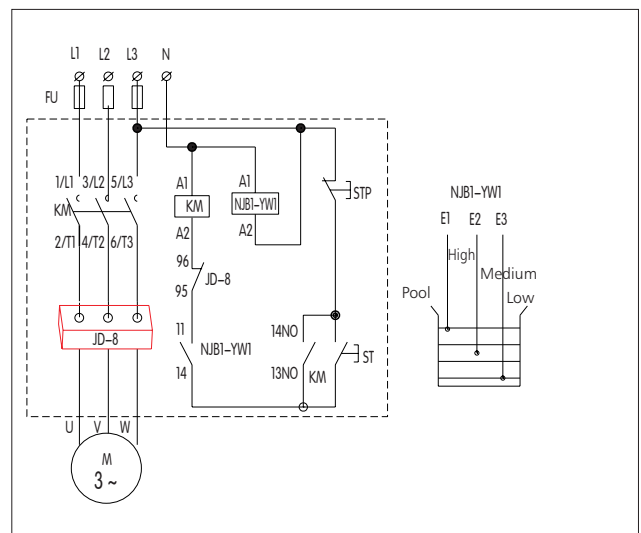

a. Connection diagram of NJBK5-10D in case both the control circuit voltage and the main circuit voltage are AC380V

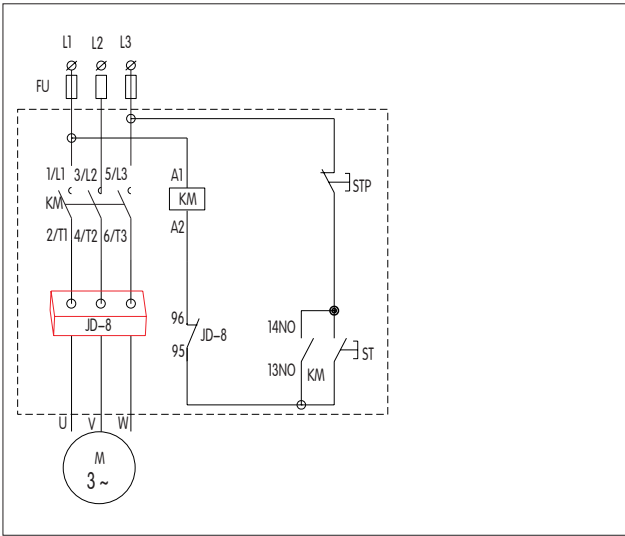

b. Connection diagram of NJBK5-10D in case the main circuit voltage is AC380V and the control circuit voltage is AC220V

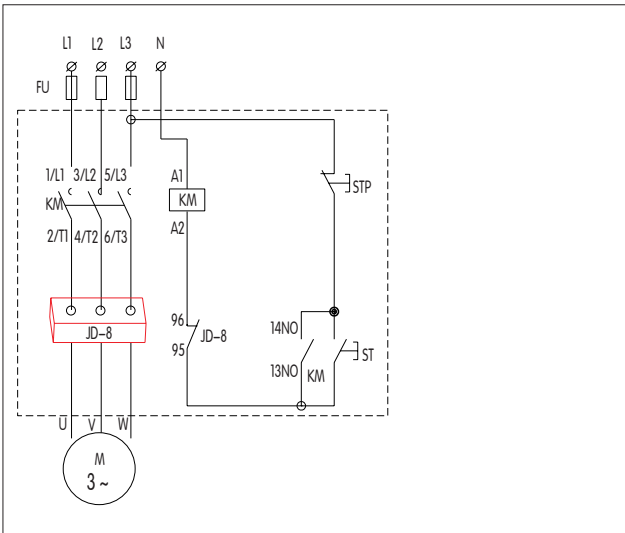

7. Overall and mounting dimensions (mm)

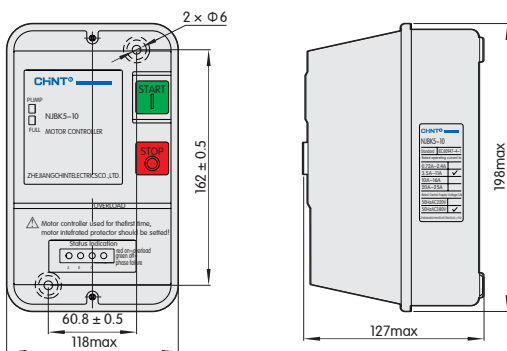



JQX-10F Miniature power relay

1. General

- 1.1 10A switching current
- 1.2 Various sockets available
- 1.3 Wide range of coil ratings
- 1.4 Certificate: UL, CE

2. Type designation

JQX-10F / 006 - 2Z

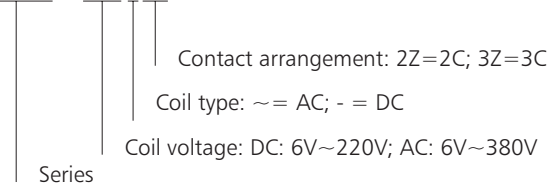

3. Technical data

Contact Arrangement		2C, 3C
Initial contact resistance	mΩ	100
Contact material		Silver alloy
Rated load (resistive)		10A/250VAC, 10A/28VDC
Max. switching voltage	VAC	250
	VDC	125
Max. switching current	A	10
Max. switching power	VA	2500
	W	280
Electrical endurance	Cycles(× 10 ³)	100
Machanical endurance	Cycles(× 10 ⁶)	10

4. Coil specification

AC

Rated voltage	Holding voltage	Must drop-out voltage	Operating range	Power consumption
6	80%Un	20%Un	(80%~110%)Un	3VA
12				
24				
36				
48				
110				
127				
220				
230				
380				

DC

Rated voltage	Holding voltage	Must drop-out voltage	Operating range	Power consumption
5	75%Un	10%Un	(75%~110%)Un	2W
6				
12				
24				
36				
48				
110				
127				
220				



5. Characteristics

Insulation resistance(at 500VDC)		M Ω	100
Dielectric strength	Between coil & contacts		1500VAC
	Between open contacts		1000VAC
Operation time		ms	≤25
Release time		ms	≤25
Shock resistance		m/s ²	100
Vibration			10~55Hz,1mm double amplitude
Humidity			98% RH at +20℃
Ambient temperature range		℃	-40~+55
Termination			Plug-in, PCB
Dimension		mm	35×35×52

6. Overall and mounting dimensions (mm)

Internal connection (bottom view)

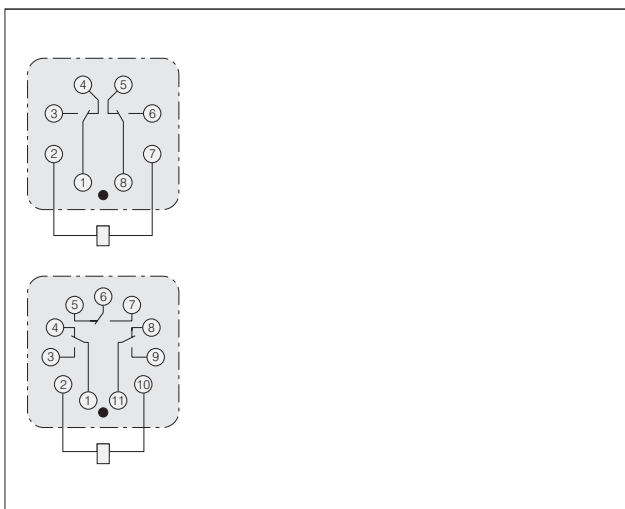

Dimensions

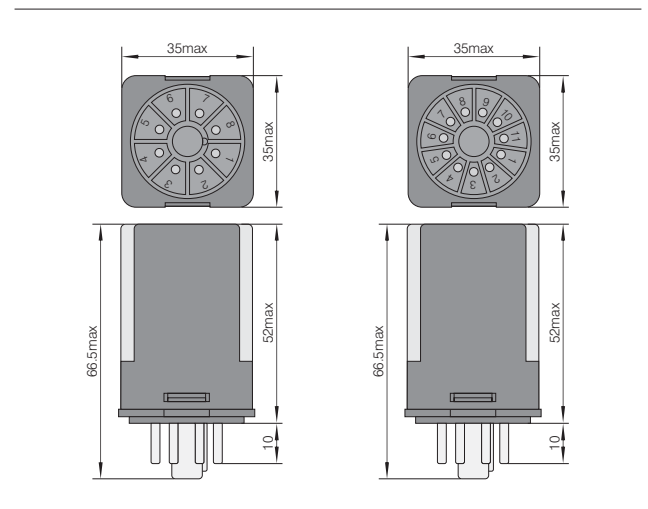



JTX Miniature power relay

1. General

- 1.1 10A switching current
- 1.2 Various sockets available
- 1.3 Wide range of coil ratings
- 1.4 Certificate: UL, CE

2. Type designation

JTX - 2C / 006 / VDC

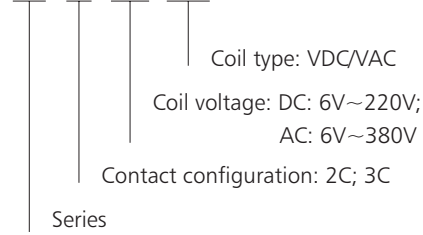

3. Technical data

Contact Arrangement		2C, 3C
Initial contact resistance	mΩ	100
Contact material		Silver alloy
Rated load (resistive)		10A/250VAC, 10A/28VDC
Max. switching voltage	VAC	250
	VDC	125
Max. switching current	A	10
Max. switching power	VA	2500
	W	280
Electrical endurance	Cycles($\times 10^3$)	100
Machanical endurance	Cycles($\times 10^6$)	10

4. Coil specification

AC

Rated voltage	Holding voltage	Must drop-out voltage	Operating range	Power consumption
6	80%Un	20%Un	(80%~110%)Un	3VA
12				
24				
36				
48				
110				
127				
220				
230				
380				

DC

Rated voltage	Holding voltage	Must drop-out voltage	Operating range	Power consumption
5	75%Un	10%Un	(75%~110%)Un	2W
6				
12				
24				
36				
48				
110				
127				
220				

5. Characteristics

Insulation resistance(at 500VDC)		MΩ	100
Dielectric strength	Between coil & contacts		1500VAC
	Between open contacts		1000VAC
Operation time		ms	≤20
Release time		ms	≤20
Shock resistance		m/s ²	100
Vibration			10~55Hz,1mm double amplitude
Humidity			98% RH at +20℃
Ambient temperature range		℃	-40~+55
Termination			Plug-in
Dimension		mm	35×35×52

6. Overall and mounting dimensions (mm)

Internal connection (bottom view)

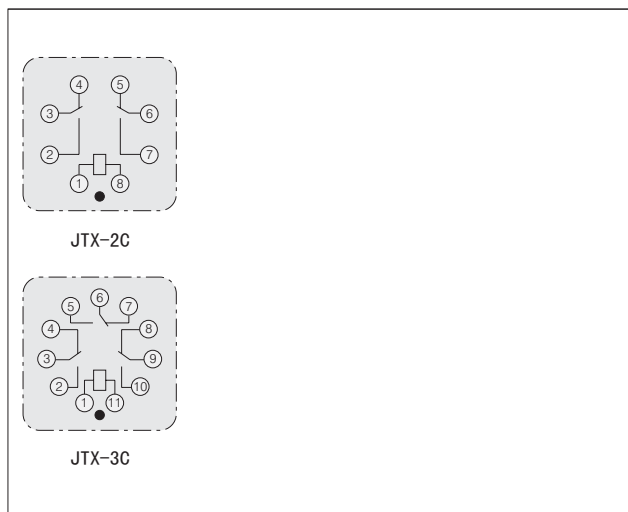

Dimensions

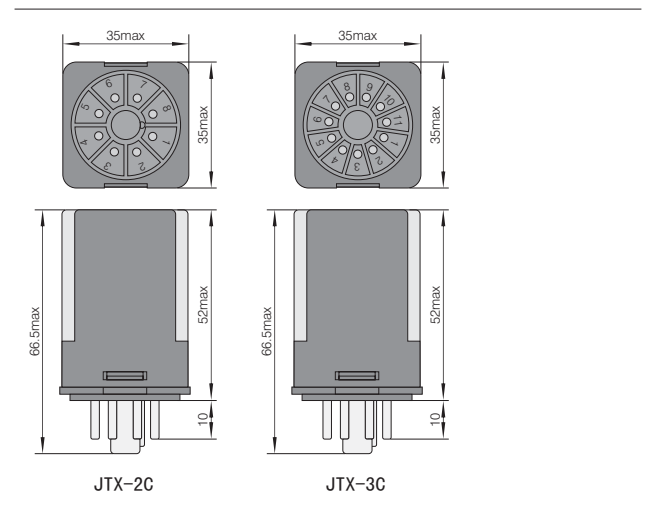



JMK Miniature power relay

1. General

- 1.1 10A switching current
- 1.2 With indicator to be selected
- 1.3 Full range of AC and DC coil
- 1.4 Certificate: UL, CE

2. Type designation

JMK 2P- I / 006 / VDC

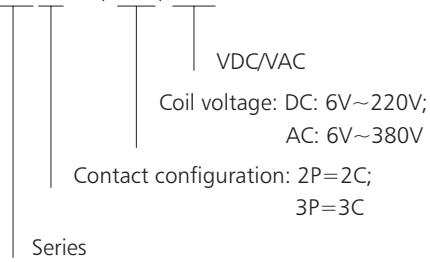

3. Technical data

Contact Arrangement		2C, 3C
Initial contact resistance	mΩ	100
Contact material		Silver alloy
Rated load (resistive)		10A/250VAC, 10A/28VDC
Max. switching voltage	VAC	250
	VDC	125
Max. switching current	A	10
Max. switching power	VA	2500
	W	280
Electrical endurance	Cycles($\times 10^3$)	100
Machanical endurance	Cycles($\times 10^6$)	10

4. Coil specification

AC

Rated voltage	Holding voltage	Must drop-out voltage	Operating range	Power consumption
6	80%Un	20%Un	(80%~110%)Un	3.5VA
12				
24				
36				
48				
110				
127				
220				
230				
380				

DC

Rated voltage	Holding voltage	Must drop-out voltage	Operating range	Power consumption
5	75%Un	10%Un	(75%~110%)Un	2W
6				
12				
24				
36				
48				
110				
127				
220				

5. Characteristics

Insulation resistance(at 500VDC)		M Ω	100
Dielectric strength	Between coil & contacts		1500VAC
	Between open contacts		1000VAC
Operation time		ms	≤20
Release time		ms	≤20
Shock resistance		m/s ²	100
Vibration			10~55Hz,1mm double amplitude
Humidity			98% RH at +20℃
Ambient temperature range		℃	-40~+55
Termination			Plug-in
Dimension		mm	35×35×53

6. Overall and mounting dimensions (mm)

Internal connection (bottom view)

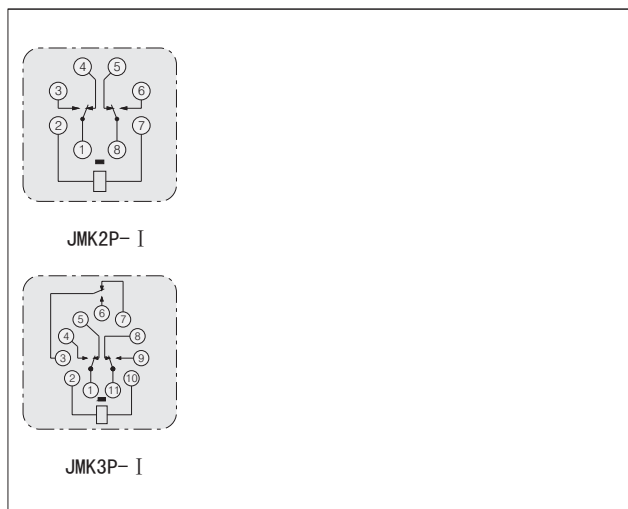

Dimensions

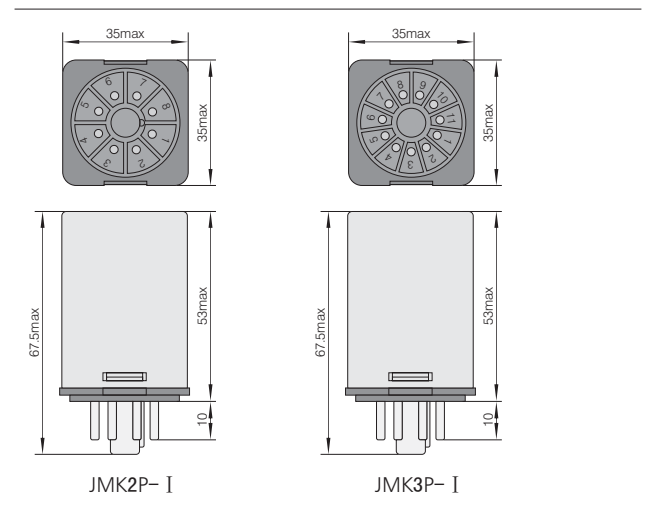



NJMC1 pulse relay

1. General

Contact switching current of up to 16A and 32A; a complete range of AC/DC specifications; in conformity with GB/T 21711.1; NJMC1 pulse relay is a mechanical bistable relay that changes the contact state by inputting pulse signals. Therefore, in comparison with common relays which remain on when the armature is closed, pulse relay features a low power consumption.

2. Type designation

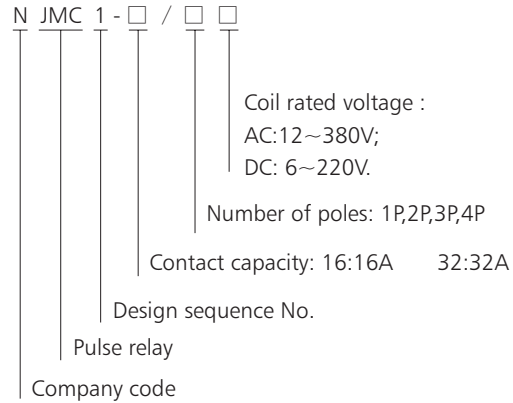

3. Normal operating conditions and mounting conditions

Temperature range	-25℃~+55℃
Pollution degree	1
Mounting position	Any
Environmental protection category	Dustproof type
Overvoltage category	II

4. Technical data

4.1 Contact data

Contact form	1P, 2P, 3P, 4P	
Initial contact resistance	100mΩ	
Contact material	Silver alloy	
Contact load (resistive)	NJMC1-16:16A 250VAC/28VDC	NJMC1-32:32A 250VAC/28VDC
Max. switching voltage	250VAC/125VDC	NJMC1-32:32A
Max. switching current	NJMC1-16:16A	NJMC1-32:8000VA 896W
Max. switching power	NJMC1-16:4000VA 448W	
Electrical life (times)	1×10 ⁵	
Mechanical life (times)	1×10 ⁶	

4.2 Specification data

Coil rated voltage VDC	Coil resistance (20℃)Ω ±10%
6	6
12	24
24	95
48	380
110	2000
127	2660
220	8000

Coil rated voltage VAC	Coil resistance (20℃)Ω ±10%
12	6
24	24
48	95
130	700
220	2000
230	2185
240	2380
380	6000

4.3 Characteristics data

Insulation resistance	100MΩ(500VDC)	
Dielectric strength	Between contact & coil	4000VDC
	Between open contacts	1500VDC
Operation time	≤20ms	
Shock (resistance)	Acceleration: 100m/s ² , pulse duration: 11ms	
Vibration	1mm double amplitude, 10~55Hz	
Mounting type	Rail type	
Overall dimensions (mm)	86×70	

4.4 Coil data

Pulse voltage duration	≥50ms (200ms is recommended)
Voltage range	85%~110%

5. Wiring diagram

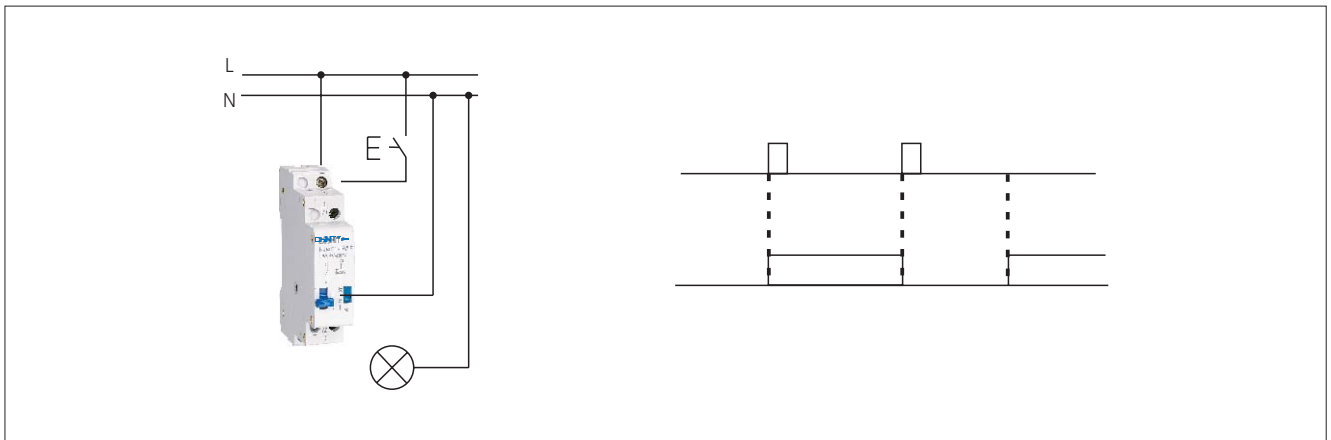

6. Overall and mounting dimensions (mm)

NJMC1-16

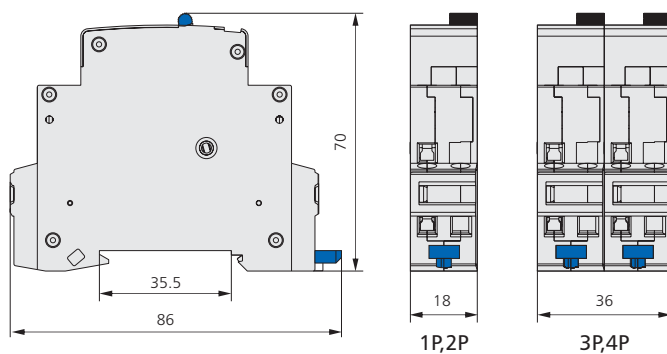

NJMC1-32

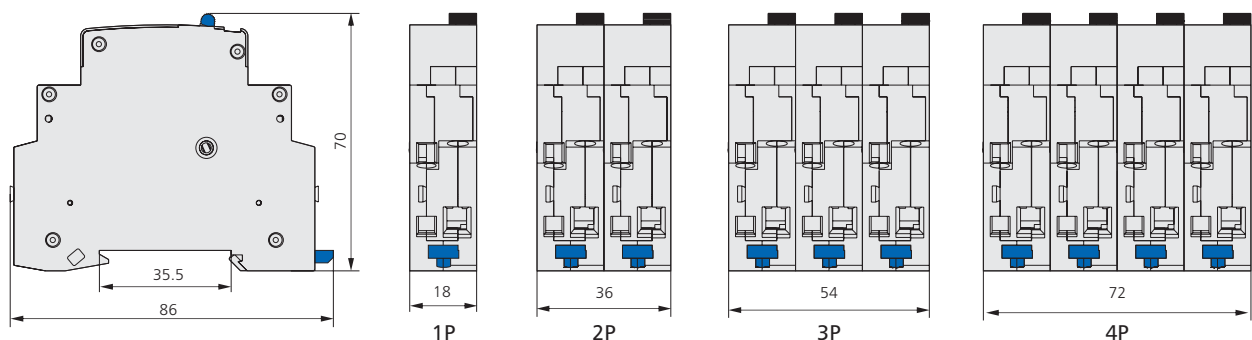

Power Relay Socket Series

CZF08A

CZF08A-E(With finger safety protection)



52×41×21.5(mm)

52×41×21.5(mm)

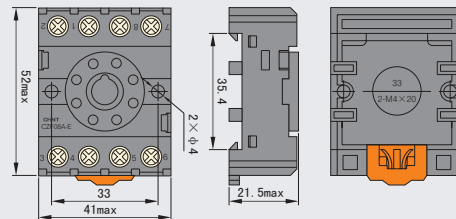
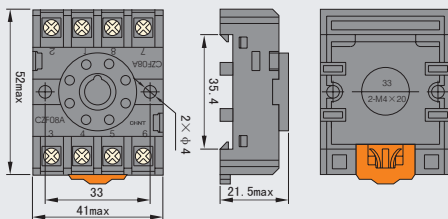

Applicable relay type: JQX-10F/2Z, JTX-2C, JMK2P-I

Applicable relay type: JQX-10F/2Z, JTX-2C, JMK2P-I

CZF11A

CZF11A-E(With finger safety protection)



52×44×31(mm)

52×44×31(mm)

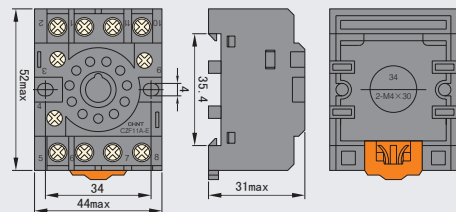
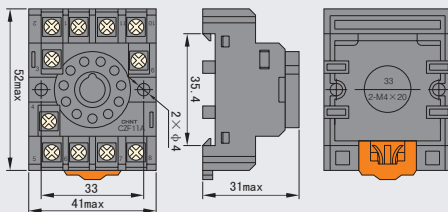

Applicable relay type: JQX-10F/3Z, JTX-3C, JMK3P-I

Applicable relay type: JQX-10F/3Z, JTX-3C, JMK3P-I

CZT08A-E(With finger safety protection)

CZT08B-01(Wide type, copper strip connection)



79×29×33(mm)

68×30×28(mm)

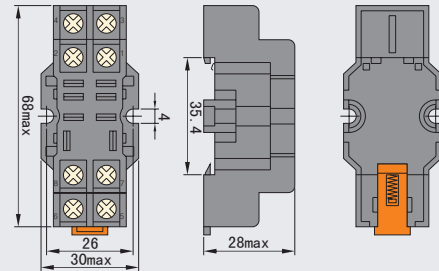
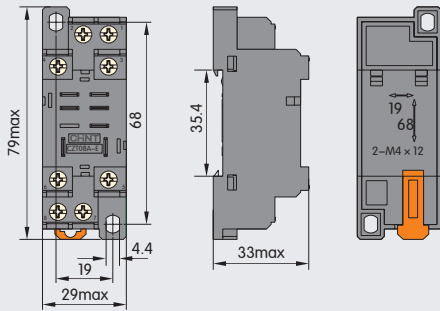

Applicable relay type: JQX-13F(B)/2Z,
NJX-13FW(B)/2Z, HH62P(-L), LY2(N)

Applicable relay type: JQX-13F(B)/2Z,
NJX-13FW(B)/2Z, HH62P(-L), LY2(N)

CZY08A-E(With finger safety protection)

CZY11A-E(With finger safety protection)



72×23×31(mm)

72×30×31(mm)

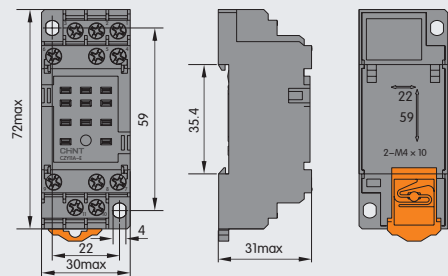
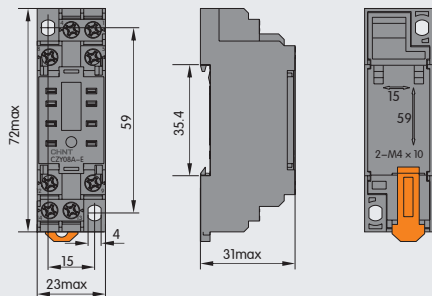

Applicable relay type: JZX-22F(B)/2Z,
NJX-13FW(B)/2ZS, HH52P(-L), MY2(N)

Applicable relay type: JZX-22F(B)/3Z,
NJX-13FW(B)/3ZS, HH53P(L), MY3(N)

CZY14A-E(With finger safety protection)

CZY08B-01(Wide type, copper strip connection)



72×30×31(mm)

63×30.5×26(mm)

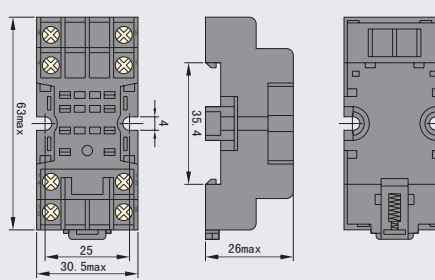
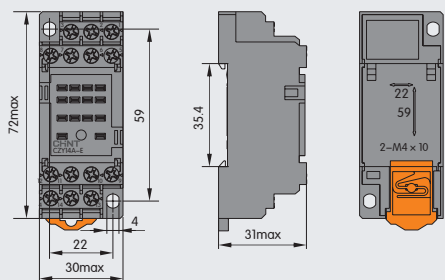

Applicable relay type: JZX-22F(B)/4Z, NJX-13FW(B)/4ZS, HH54P(L), MY4(N)

Applicable relay type: JZX-22F(B)/2Z, NJX-13FW(B)/2ZS, JZX-18F(L)/2Z, HH52P(L), MY2(N)

CZY11B (Copper strip connection)

CZY14B (Copper strip connection)



63×30.5×26(mm)

63×30.5×26(mm)

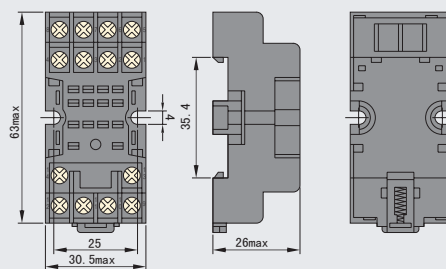
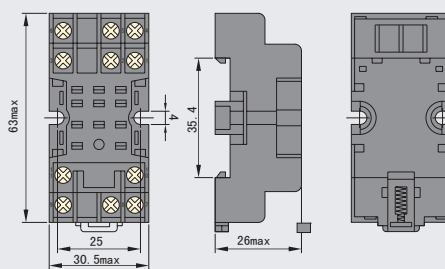

Applicable relay type: JZX-22F(B)/3Z, NJX-13FW(B)/3ZS, HH53P(L), MY3(N)

Applicable relay type: JZX-22F(B)/4Z, NJX-13FW(B)/4ZS, HH54P(L), JZX-18F(L)/4Z, MY4(N)

CZY14B-E (With finger safety protection, copper strip connection)



63×30.5×26(mm)

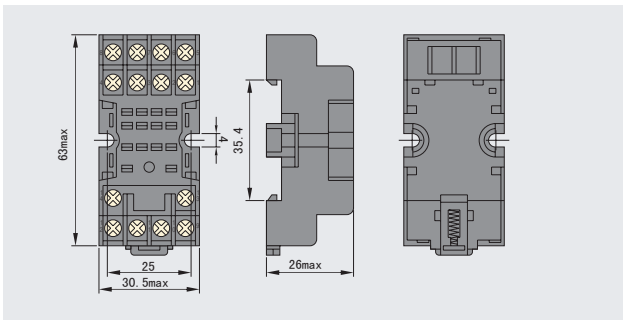

Applicable relay type: JZX-22F(B)/4Z, NJX-13FW(B)/4ZS, HH54P(L), JZX-18F(L)/4Z, MY4(N)

NG102

NG103



Applicable relay type: CZT series、CZY series

Applicable relay type: CZY□B series、CZT□B series



NJBK5-5 Motor Controller

1. General

NJBK5-5 motor controller (hereinafter referred to as controller) is mainly used in circuits with a frequency of AC 50Hz/60Hz, a rated operational voltage of up to 220V and a rated control power of up to 2.2kW (current up to 20A) to control the direct start and stop of single-phase water pumps, provide overload and underload protection (pump runaway protection), and realize automatic liquid level control for civil water towers and reservoirs.

This product is not applicable to the liquid level control of oil, purified water, inflammable and explosive chemical liquids, corrosive liquids and high-density sewage.

Standards: IEC 60947-4-1

2. Type designation

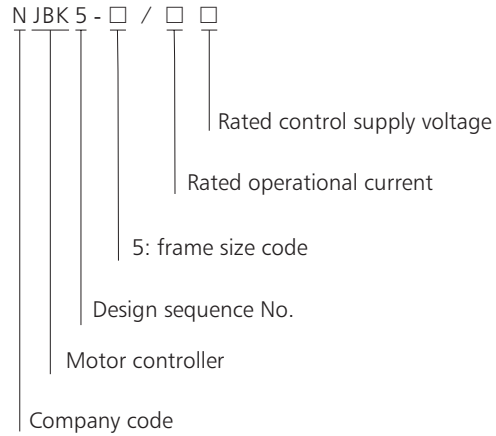

3. Operation conditions

- 3.1 Altitude: the altitude of the mounting location should not exceed 2000m;
- 3.2 Ambient temperature: $-5^{\circ}\text{C} \sim +40^{\circ}\text{C}$, and the average temperature in 24h should not exceed $+35^{\circ}\text{C}$;
- 3.3 Atmospheric conditions: The relative air humidity at the mounting location should not exceed 50% at the maximum temperature of $+40^{\circ}\text{C}$. The relative humidity may be higher at lower temperatures. Special measures should be taken if condensation occurs on the product occasionally due to temperature variation.
- 3.4 Pollution degree: 3;
- 3.5 Mounting category: II ;
- 3.6 In places where there is no significant vibration or impact;
- 3.7 In non-explosive media that do not contain a sufficient amount of gas or dust to cause metal corrosion or insulation failure;
- 3.8 In places where rain and snow protection is provided;
- 3.9 The inclination from the vertical plane should not exceed 5° .

4. Technical data

4.1 Main data and technical characteristics

Model	Type	Conventional heating current (A)	Setting current range (A)	Rate power		Rated operational voltage (V)	Rated operational current (A)
				kW	HP		
NJBK5-5	2A~10A	20	2A~10A	0.25~1.1	1/3~1.5	AC220	AC-120
	4A~20A		4A~20A	0.55~2.2	3/4~3		

4.2 Rated control supply voltage U_s : AC220V.

4.3 Rated control supply voltage fluctuation range: (85%~110%) U_s .

4.4 Degree of protection of enclosure: IP20.

4.5 Operating characteristics

4.5.1 When overload protection is active, the red "Fault" indicator of the controller lights up permanently, and overload protection operates according to tripping class 10, see Table 2.

Table 2 Operating characteristics of overload protection

No.	Setting current multiple	Operation time	Starting conditions
1	1.05	No operation within 2h	Cold state start
2	1.2	Operation within 2h	Start after No.1
3	1.5	$\leq 4\text{min}$	Start after applying a 1.0 times setting current for 2h
4	7.2	$4s < T_p \leq 10s$	Cold state start

4.5.2 Operating characteristics of underload protection (pump runaway protection): When the actual operational current of the pump motor is less than 20%~100% of the rated current of the motor, the red "Fault" indicator of the controller flashes and, after a delay of $60s \pm 10s$, the controller stops operation.

4.5.3 Protection return characteristics: After the operation of the overload or underload protection (pump runaway protection) of the controller, the controller restarts automatically after a delay of $30\text{min} \pm 3\text{min}$.

4.5.4 Reset characteristics: power-off reset, the reset time $\leq 1\text{min}$.

4.6 Down-lead distance of liquid level control electrode: 500m max.

4.7 Requirements for the liquid under control: general domestic water or high-conductivity sewage.

4.8 Mounting type: installation type.

5. Structure and principle

The controller consists of four parts, enclosure, base, sealing ring and main control panel. The enclosure has a "Force Start" button, which is used to start the pump motor forcibly to fill the pool when the highest water level has not been reached and becomes invalid when the highest water level has been reached. It also has a "Power" switch, which is used to switch on or off the power supply of the controller (position "1" is on, and position "0" is off).

There are three liquid level detection electrode wires in the controller, E1, E2 and E3, which should be connected and installed in high, medium and low positions in the pool under control by the user. When the water level in the pool is lower than position E3, the controller starts the pump motor to pump water and the yellow "Water Level" indicator on the controller panel flashes, until the water level in the pool reaches position E1. At this time, the yellow "Water Level" indicator on the controller panel lights up permanently and the pump stops pumping.

6. Installation and commissioning

6.1 Before installation, read the operating instructions carefully. Then, connect the wires in accordance with the connection diagram. During connection, the live wire and neutral wire of the controller power supply should be distinguished from each other, the three liquid level detection electrodes in the controller, E1, E2 and E3, should be installed in high, medium and low positions in the pool under control by the user, the terminals should be highly conductive.

6.2 Before the controller is put into use, overload setting must be carried out. Otherwise, overload protection will be inactive. Overload setting is accomplished by simply setting the current value on the overload dial of the controller to the rated current of the motor. The underload setting value can generally be 50% of the rated current. The user may also carry out underload setting after detecting the no-load current of the motor and calculating the percentage to the rated current.

6.3 After checking the connection and carrying out overload and underload setting, press the power switch on the controller panel to switch on the power supply and carry out relevant overload and underload tests. The controller may be used only if it operates normally. If a fault occurs, check the connection or the overload and underload setting.

7. Wiring diagram

Figure 1 Connection diagram

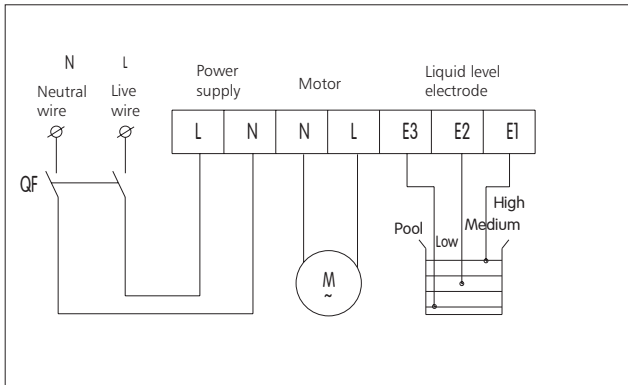
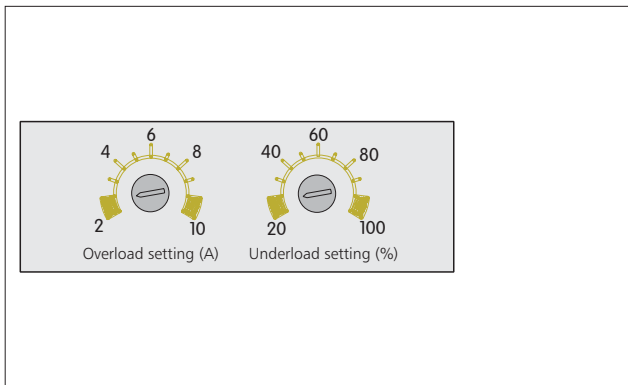
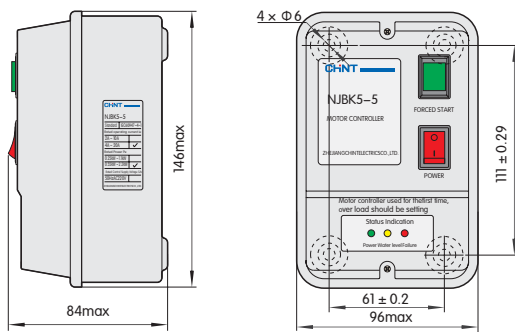

Figure 2 Schematic diagram of setting knob



8. Overall and mounting dimensions (mm)





NJBK6 Motor Protection Relay

1. General

NJBK6 series motor protection relay is used to provide overload, phase failure, three-phase current unbalance and locked rotor protection for AC motors with a frequency of AC 50Hz, a rated insulation voltage of below 690V and a rated operational current of 1A~36A that operate continuously or intermittently.

Standards: IEC 60947-4-1

2. Type designation

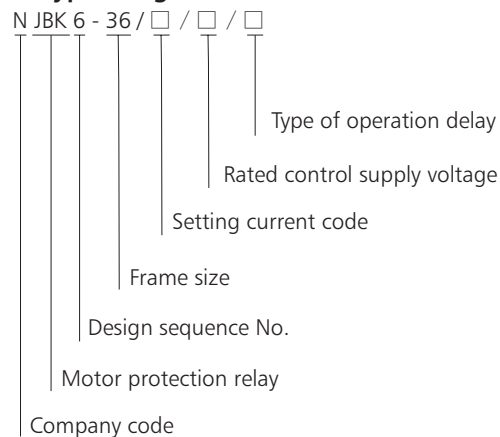

3. Operation conditions

- 3.1 Altitude: should not exceed 2000m;
- 3.2 Ambient temperature: $-5^{\circ}\text{C}\sim+40^{\circ}\text{C}$, and the average temperature in 24h should not exceed $+35^{\circ}\text{C}$;
- 3.3 Atmospheric conditions: The relative air humidity should not exceed 50% at the maximum temperature of $+40^{\circ}\text{C}$. The relative humidity may be higher at lower temperatures, for example, the air humidity can be up to 90% at $+20^{\circ}\text{C}$. Special measures should be taken if condensation occurs on the product occasionally due to temperature variation;
- 3.4 Pollution degree: 3;
- 3.5 The inclination between the mounting plane and the vertical plane should not exceed $\pm 5^{\circ}$;
- 3.6 In non-explosive media that do not contain a sufficient amount of gas or conductive dust to cause metal corrosion or insulation failure;
- 3.7 In places with rain and snow protection equipment and not full of vapor;
- 3.8 In places where there is no significant shake, impact or vibration;
- 3.9 Mounting category: III

4. Technical data

4.1 Main data and technical characteristics

No.	Setting current range	Model of matching contactor	Matching motor power
NJBK6-36/3/□/□	1A~3A	CJX2-25/NC1-25	0.5kW~1.5kW
NJBK6-36/9/□/□	3A~9A	CJX2-25/NC1-25	1.5kW~4.5kW
NJBK6-36/24/□/□	8A~24A	CJX2-25/NC1-25	4kW~12kW
NJBK6-36/36/□/□	12A~36A	CJX2-32/NC1-32	6kW~18kW

4.2 Technical data of main circuit

Rated operational current: 1A~36A, rated insulation voltage: 690V, rated frequency: 50Hz;

4.3 Technical data of control circuit

Number of contacts: 1 group of change-over contacts;

Contact capacity: Ue/Ie: AC-15 380V/0.95A, 240V/1.5A; Ith: 5A;

Rated frequency: 50Hz;

4.4 Technical data of auxiliary circuit

Control supply voltage: AC 220×(1±10%)V, AC 380×(1±10%)V;

Rated frequency: 50Hz;

4.5 Operating characteristics

4.5.1 The operating characteristics of overload protection are given in Table 2.

No.	Setting current multiple	Operation time	Starting conditions	Starting conditions
1	1.05	No operation within 2h	Cold state	+20℃
2	1.2	Operation within 2h	Hot Start	+20℃
3	1.5	Operation within 2min	Hot Start	+20℃
4	7.2	2s<Tp≤10s	Cold state	+20℃

4.5.2 Operating characteristics of phase failure protection

In case of failure of any phase of the three-phase current of the main circuit, the protector operates for a period of ≤5s.

4.5.3 Operating characteristics of three-phase current unbalance protection

When the three-phase current of the main circuit meets the following two formulas, the protector operates for a period of ≤5s.

$$\frac{I_{max}-I_{min}}{I_{avr}} \times 100\% > 30\%$$

$$I_{max} \geq 0.5 \times I_{set}$$

where: I_{max}: Max. current value of the three-phase current;

I_{min}: Min. current value of the three-phase current;

I_{avr}: average value of the three-phase current;

I_{set}: setting current value.

4.5.4 Operating characteristics of locked rotor protection

The locked rotor current is set to 6I_e in the protector. When the current of the main circuit is greater than the locked rotor current, the protector operates for a period of ≤10s after a delay.

4.6 Reset characteristics

After the operation of the protector, if the control supply voltage is normal, the protector can be reset manually; if the control supply voltage is off, the protector resets immediately.

5. Connection diagram

The connection diagrams in case the control supply voltage is AC220V and AC380V are shown in Figure 2 and Figure 3.

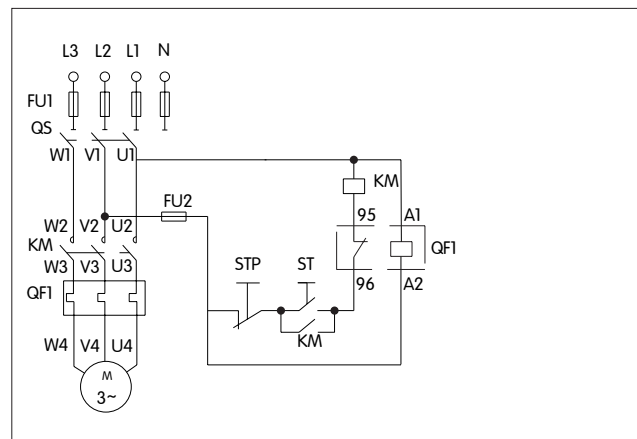
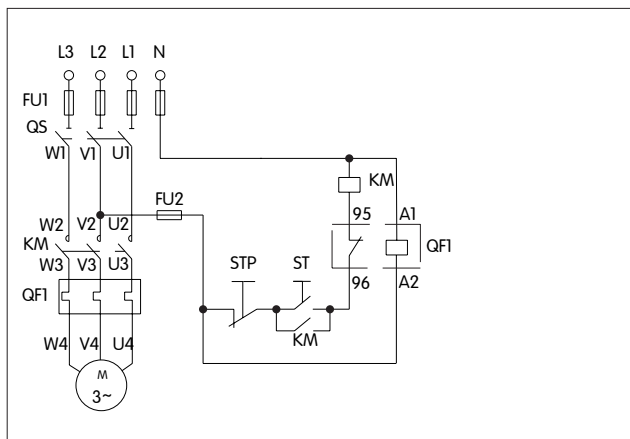

6. Installation and commissioning

6.1 Before installation, read the operating instructions carefully. Then, connect the wires in accordance with the connection diagram.

6.1.1 Terminals A1 and A2 are the control power supply input terminals of the protector; 95 and 96 are the output control terminals (N/C), 95 and 98 are N/O contacts.

6.1.2 Plug the protector into the outlet terminal of the contactor and connect the control circuit in accordance with Figure 2 and Figure 3.

6.2 Adjustment of setting current value

Adjust the setting value of the protector using the setting knob with indicating arrow and the setting current value on the label plate according to the rated current marked on the motor nameplate and the load conditions of the motor. Adjust the setting current value of the protector to the scale equal to the rated current value marked on the motor nameplate.

6.3 Commissioning: After checking the connection and setting, switch on the power supply and operate the start button. The motor should run normally and the (green) running indicator on the protector panel should light up. If the red indicator flashes, finely adjust the setting value until the red indicator stops flashing.

7. Structure and principle

7.1 Operating principle: The protector detects the current of the main circuit of the motor by means of the current transformer and judge if overload or phase failure has occurred in the motor. In case of overload, it simulates the heat accumulation state of the motor by means of the singlechip and, when the heat accumulation reaches the set limit, disconnects the N/C contact of the built-in electromagnetic relay.

7.2 Structural features

7.2.1 Has phase failure, overload, three-phase current unbalance and locked rotor protection functions.

7.2.2 Has two indicators indicating running and fault states.

7.2.3 Has a setting current quantified continuously adjustable device.

7.2.4 The main circuit uses plug-in connection for use in combination with the specified model of contactor.

8. Overall and mounting dimensions (mm)

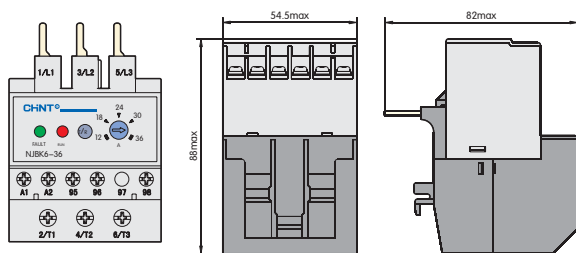

9. Environmental conditions for the storage of the protector

9.1 Temperature: $-25^{\circ}\text{C} \sim +40^{\circ}\text{C}$

9.2 Relative humidity (at 25°C): should not exceed 85%

9.3 Protect from rain and snow

9.4 The guaranteed storage period of the product is 18 months.

Products exceeding the storage period must be reinspected before being put into use.



NJBK7 Motor protection delay

1. General

NJBK7 series motor protection relay (hereinafter referred to as protector) is used to provide overload, locked rotor, phase failure, three-phase current unbalance, ground and PTC temperature protection for AC motors with a frequency of AC 50Hz, a rated insulation voltage of up to 690V and a rated operational current of 80A-800A that operate continuously or intermittently. The protector uses flexible Rogowski coil to acquire current and features wide setting current range, high accuracy and convenient installation. The protector has RS485 interface and 4mA-20mA analog transmission interface, permits network communication and can realize remote monitor and control and fault inquiry of motors by means of upper computer. The protector is generally used in combination with AC contactor.

Standards: GB 14084.4, IEC 60947-4-1.

2. Type designation

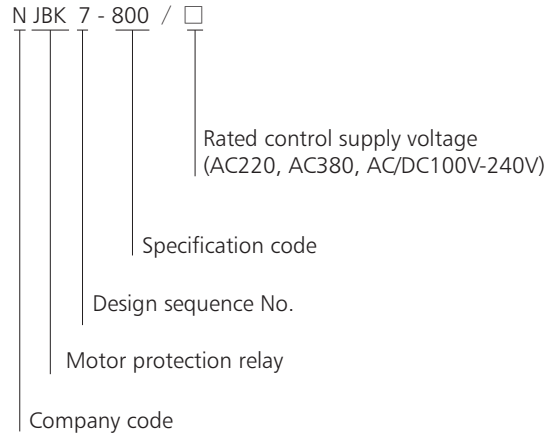

3. Technical data

- 3.1 Altitude: should not exceed 2000m;
- 3.2 Ambient temperature: -5°C~+40°C, and the average temperature in 24h should not exceed +35°C;
- 3.3 Atmospheric conditions: The relative air humidity should not exceed 50% at the maximum temperature of +40°C. The relative humidity may be higher at lower temperatures, for example, the air humidity can be up to 90% at +20°C. Special measures should be taken if condensation occurs on the product occasionally due to temperature variation;
- 3.4 Pollution degree: 3;
- 3.5 The inclination between the mounting plane and the vertical plane should not exceed ±5°;
- 3.6 In non-explosive media that do not contain a sufficient amount of gas or conductive dust to cause metal corrosion or insulation failure;
- 3.7 In places with rain and snow protection equipment and not full of vapor;
- 3.8 In places where there is no significant shake, impact or vibration;
- 3.9 Mounting category: III;
- 3.10 Degree of protection of enclosure: Ip20.

4. Main data and technical characteristics

4.1 Main circuit: rated insulation voltage: AC690V, rated frequency: 50Hz

Model	Setting current (A)	Setting current range (A)	Matching motor power (kW)
NJBK7-800/□	800	80~800	40~400

4.2 Auxiliary circuit: rated insulation voltage: AC380V, rated frequency: 50Hz, data of auxiliary contact

Usage category	AC-15	
Rated operational voltage Ue(V)	240	380
Rated operational current Ie(A)	1.5	0.95
Conventional heating current Ith(A)	5	

4.3 Structural features

- 4.3.1 Split mounting;
- 4.3.2 LCD display, key setting;
- 4.3.3 Has start delay function;
- 4.3.4 Has fault memory function, permits inquiry of fault record;
- 4.3.5 Has RS485 interface, supports MODBUS protocol, permits network communication;
- 4.3.6 Has 4mA-20mA analog output interface;
- 4.3.7 Has two groups of output contacts, 1Z protection contact and 1H auxiliary contact, and permits autotransformer reduced voltage starting and star-delta starting;
- 4.3.8 Power consumption: ≤3VA.

5. Protection characteristics

5.1 Operating characteristics of overload protection

Overload curve	Overload multiple								Note
	1.1	1.2	1.5	2	5	6	7.2		
Kr=1	75	63	40	22	3.6	2.5	1.8		
Kr=2	150	125	80	45	7.2	5	3.5	In conformity with Class 10A	
Kr=3	298	250	160	90	14	10	6.9	In conformity with Class 10	
Kr=4	595	500	320	180	29	20	14	In conformity with Class 20	
Kr=5	892	750	480	270	43	30	21	In conformity with Class 30	

5.2 Operating characteristics of phase failure protection

When the current of any phase of the three-phase current of the main circuit is equal to zero, the protector operates for a period of ≤5s.

5.3 Operating characteristics of three-phase current unbalance protection

When the three-phase current of the main circuit meets the following formula, the protector operates for a period of ≤5s.

$$\frac{I_{max}-I_{min}}{I_{max}} \times 100\% \geq \text{set current unbalance rate}$$

I_{max}: Max. phase current value

I_{min}: Min. phase current value

5.4 Operating characteristics of ground protection

When zero sequence current ≥ set ground protection current value, the protector operates for a period of ≤1s.

5.5 Operating characteristics of locked rotor protection

When Max. phase current ≥ setting current value × set locked rotor multiple, the protector operates for a period of ≤ 1s.

5.6 Operating characteristics of temperature protection

The over-temperature protection function of the protector is accomplished by detecting the resistance of the PTC thermistor preembedded in the motor stator winding. When the resistance of the PTC thermistor ≥ 2.5kΩ, the protector operates for a period of ≤ 1s.

5.7 Communication: The protector provides RS485 interface and supports MODBUS protocol.

Tripping characteristic curve

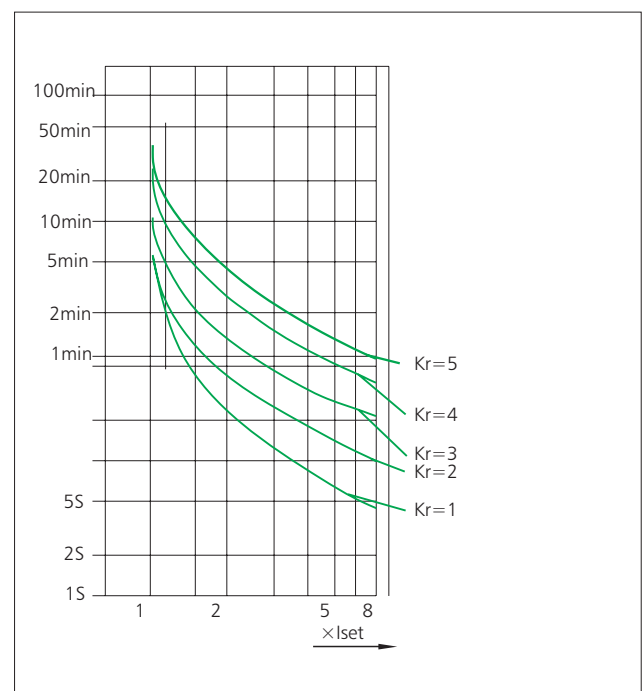

6. Connection diagram

Figure 1 Direct starting connection diagram in case the control supply voltage is 220V and the rated operational voltage is 220V

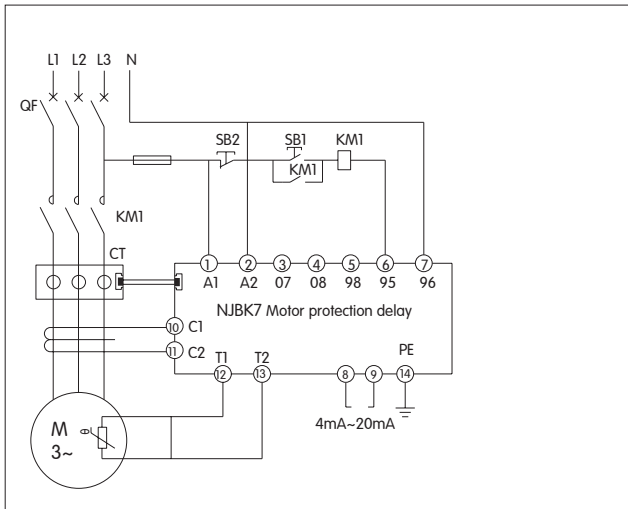

Figure 2 Secondary current direct starting connection diagram in case the control supply voltage is 220V and the rated operational voltage is 220V

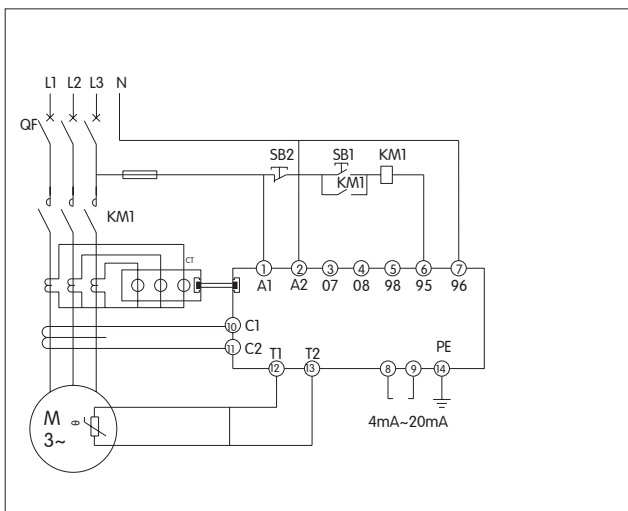

Figure 3 Autotransformer reduced voltage starting connection diagram in case the control supply voltage is 220V and the rated operational voltage is 220V

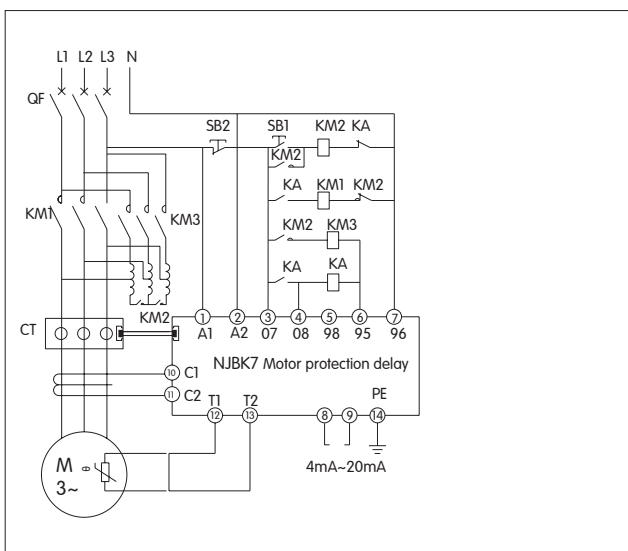
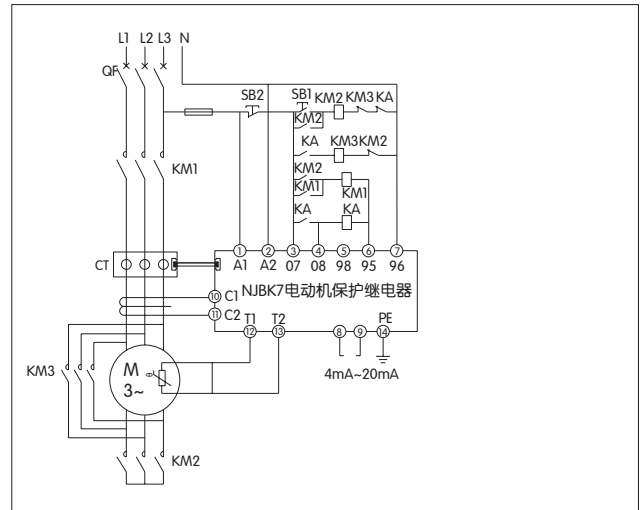

Figure 4 Star-delta starting connection diagram in case the control supply voltage is 220V and the rated operational voltage is 220V



7. Overall and mounting dimensions (mm)

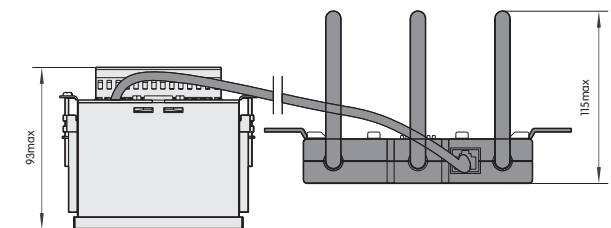
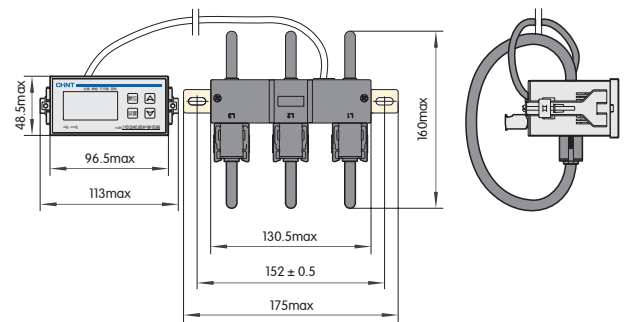

Figure 6 Transformer mounting type 1

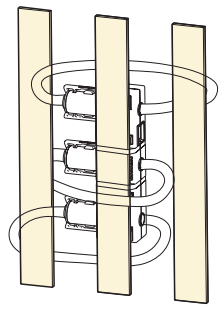

Figure 7 Transformer mounting type 2

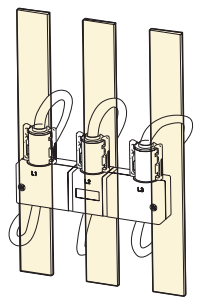
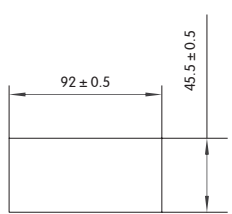

Figure 8 Opening size of the main machine





NJBK9 Motor protection relay

1. General

NJBK9 series motor protection relay (hereinafter referred to as "Pro-recter") is used for overload protection, locked rotor protection, phase failure protection, three-phase unbalance protection, grounding protection and PTC temperature protection for AC electromotors of a frequency of 50Hz with a rated insulation voltage of up to 690V and a rated operating current of 1A-200A during long-term and discontinuous operation.

This protector is provided with RS485 interface and 4-20mA current loop transmitter interface for network communication and performs remote monitor & control on the motor and fault query through opper computer.

This protector is usually used to combine with AC contactor.
Standards: IEC 60947-4-1

2. Type designation

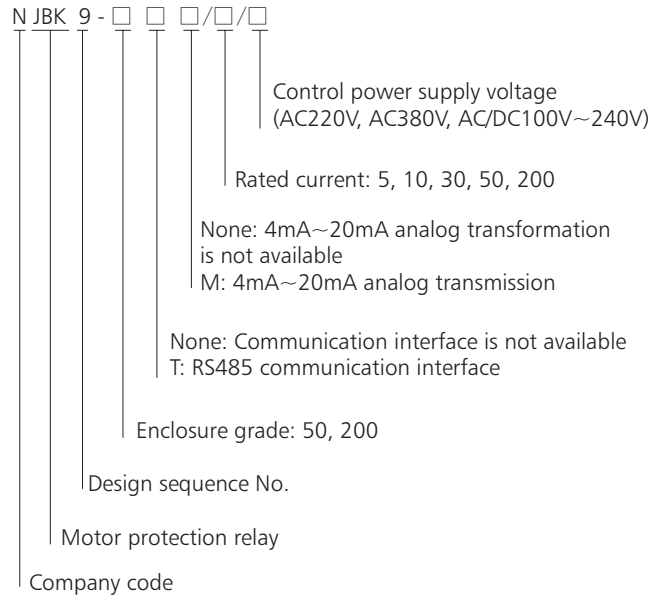

3. Operation conditions

- 3.1 Altitude: should not exceed 2000m;
- 3.2 Ambient temperature: -5℃~+40℃, and the average temperature in 24h should not exceed +35℃;
- 3.3 Atmospheric conditions: The relative air humidity should not exceed 50% at the maximum temperature of +40℃. The relative humidity may be higher at lower temperatures, for example, the air humidity can be up to 90% at +20℃. Special measures should be taken if condensation occurs on the product occasionally due to temperature variation;
- 3.4 Pollution degree: 3;
- 3.5 The inclination between the mounting plane and the vertical plane should not exceed ±5°;
- 3.6 In non-explosive media that do not contain a sufficient amount of gas or conductive dust to cause metal corrosion or insulation failure;
- 3.7 In places with rain and snow protection equipment and not full of vapor;
- 3.8 In places where there is no significant shake, impact or vibration;
- 3.9 Mounting category: III;
- 3.10 Degree of protection of enclosure: IP20.

4. Technical data

4.1 Main circuit: rated insulation voltage: AC690V, rated frequency: 50Hz

Model	Setting current (A)	Setting current range (A)	Matching motor power (kW)
NJBK9-50□□/5/□	5	1~5	0.5~2.5
NJBK9-50□□/10/□	10	2~10	1~5
NJBK9-50□□/30/□	30	6~30	3~15
NJBK9-50□□/50/□	50	10~50	5~25
NJBK9-50□□/200/□	200	40~200	20~100

4.2 Auxiliary circuit: rated insulation voltage: AC380V, rated frequency: 50Hz, data of auxiliary contact

Usage category	AC-15	
Rated operational voltage Ue(V)	240	380
Rated operational current Ie(A)	1.5	0.95
Conventional heating current Ith(A)	5	

4.3 Product selection table

Model	Overload	Phase failure	Ground	PTC	Communication	4mA~20mA	Unbalance	Locked rotor
NJBK9-50/□/□	◆	◆	◆	◆			◆	◆
NJBK9-50T/□/□	◆	◆	◆	◆	◆		◆	◆
NJBK9-50M/□/□	◆	◆	◆	◆		◆	◆	◆
NJBK9-50TM/□/□	◆	◆	◆	◆	◆	◆	◆	◆
NJBK9-200/□/□	◆	◆	◆	◆			◆	◆
NJBK9-200T/□/□	◆	◆	◆	◆	◆		◆	◆
NJBK9-200M/□/□	◆	◆	◆	◆		◆	◆	◆
NJBK9-200TM/□/□	◆	◆	◆	◆	◆	◆	◆	◆

4.4 Structural features

4.4.1 Split mounting;

4.4.2 LCD display, key setting;

4.4.3 Has start delay function;

4.4.4 Has fault memory function, permits inquiry of fault record;

4.4.5 Has RS485 interface, supports MODBUS protocol, permits network communication;

4.4.6 With 4mA-20mA analog output interface;

4.4.7 Has two groups of output contacts, 1Z protection contact and 1H auxiliary contact, and permits autotransformer reduced voltage starting and star-delta starting;

4.4.8 Power consumption: ≤3VA.

5. Protection characteristics

5.1 Operating characteristics of overload protection

Overload curve	Overload multiple								Note
	1.1	1.2	1.5	2	5	6	7.2		
Kr=1	75	63	40	22	3.6	2.5	1.8		
Kr=2	150	125	80	45	7.2	5	3.5	In conformity with Class 10A	
Kr=3	298	250	160	90	14	10	6.9	In conformity with Class 10	
Kr=4	595	500	320	180	29	20	14	In conformity with Class 20	
Kr=5	892	750	480	270	43	30	21	In conformity with Class 30	

5.2 Operating characteristics of phase failure protection

When the current of any phase of the three-phase current of the main circuit is equal to zero, the protector operates for a period of $\leq 5s$.

5.3 Operating characteristics of three-phase current unbalance protection

When the three-phase current of the main circuit meets the following formula, the protector operates for a period of $\leq 5s$.

$$\frac{I_{max}-I_{min}}{I_{max}} \times 100\% \geq \text{set current unbalance rate}$$

I_{max} : Max. phase current value

I_{min} : Min. phase current value

5.4 Operating characteristics of ground protection

When zero sequence current \geq set ground protection current value, the protector operates for a period of $\leq 1s$.

5.5 Operating characteristics of locked rotor protection

When Max. phase current \geq setting current value \times set locked rotor multiple, the protector operates for a period of $\leq 1s$.

5.6 Operating characteristics of temperature protection

The over-temperature protection function of the protector is accomplished by detecting the resistance of the PTC thermistor preembedded in the motor stator winding. When the resistance of the PTC thermistor $\geq 2.5k\Omega$, the protector operates for a period of $\leq 1s$.

5.7 Communication: The protector provides RS485 interface and supports MODBUS protocol.

Tripping characteristic curve

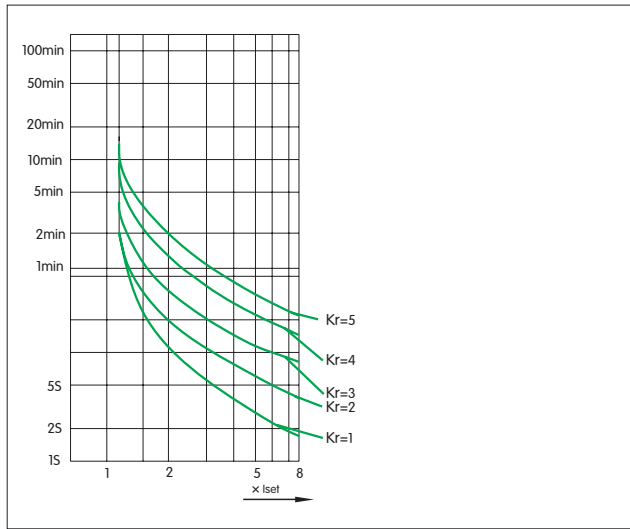

6. Connection diagram

Figure 1 Direct starting connection diagram in case the control supply voltage is 220V and the rated operational voltage is 220V

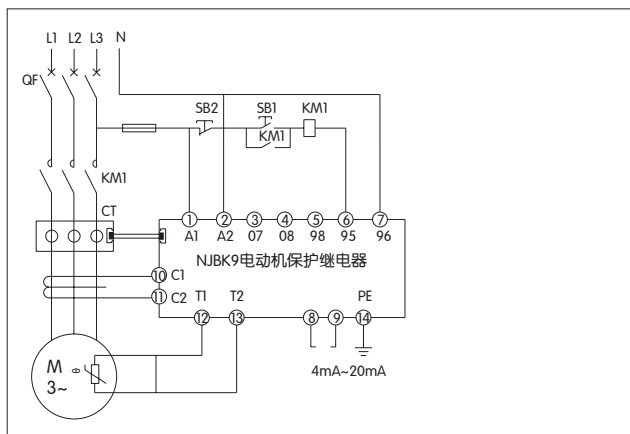

Figure 2 Secondary current direct starting connection diagram in case the control supply voltage is 220V and the rated operational voltage is 220V

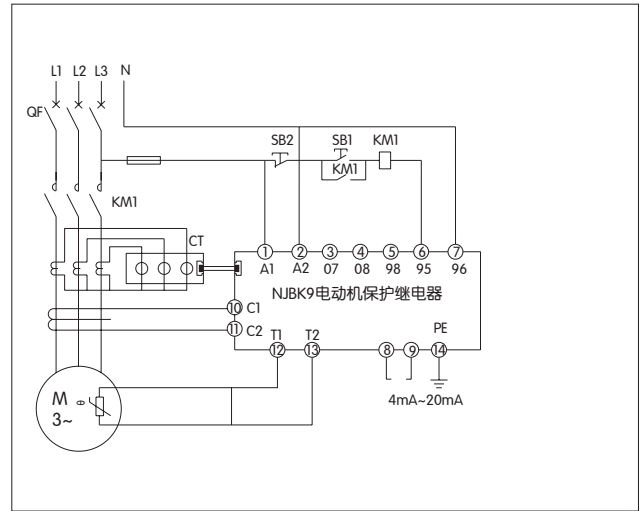

Figure 3 Autotransformer reduced voltage starting connection diagram in case the control supply voltage is 220V and the rated operational voltage is 220V

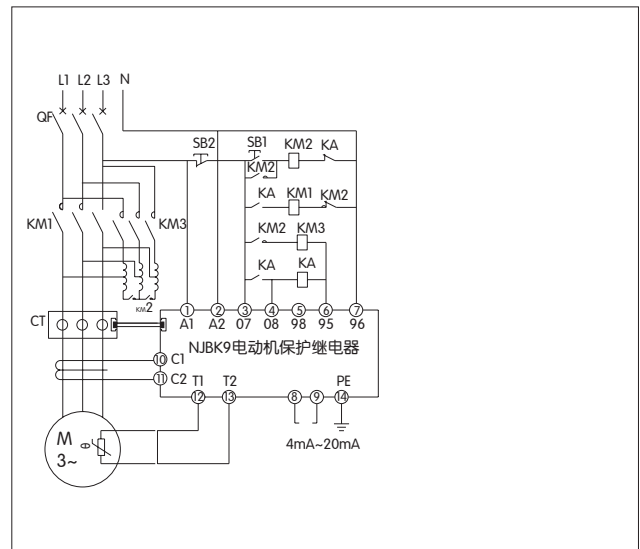
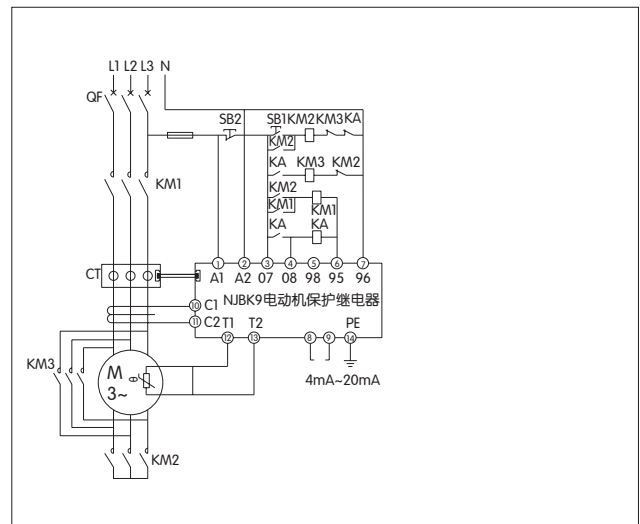

Figure 4 Star-delta starting connection diagram in case the control supply voltage is 220V and the rated operational voltage is 220V



7. Overall and mounting dimensions (mm)

NJBK9-50 overall mounting dimensions

Opening size of the main machine

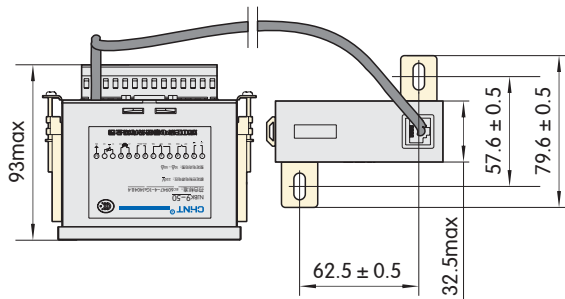
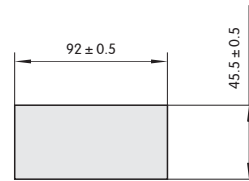
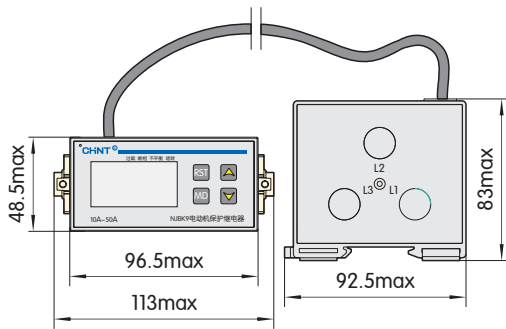

NJBK9-200 overall mounting dimensions

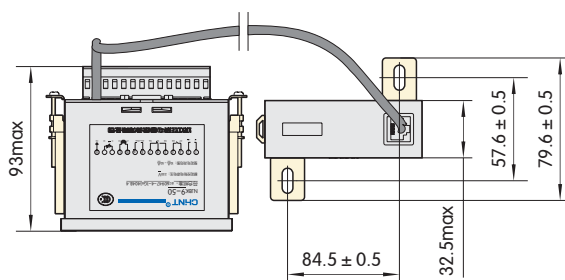
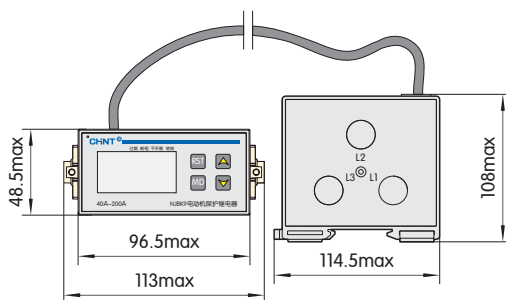



NJXB3 Relay

1. General

NJXB3 relay is used as an overvoltage, undervoltage, phase failure, phase sequence, three-phase voltage unbalance and PTC temperature protection device in three-phase three-wire control circuits with an AC voltage of 380V and a frequency of 50Hz and three-phase four-wire control circuits with an AC voltage of 220V and a frequency of 50Hz to make and break the circuit.

2. Type designation

N J X B 3 - □ □



P: PTC temperature protection, optional.

1~18 function code (see Table 1)

Design sequence No.

Phase protection

Relay

Company code

Model	Three-phase three-wire	Three-phase four-wire	Single-phase/two-phase	Overvoltage protection	Undervoltage protection	Unbalance protection	Phase sequence protection	Phase failure protection	PTC temperature protection
NJXB3-1	●			●				●	
NJXB3-2	●				●			●	
NJXB3-3	●			●	●			●	
NJXB3-4	●			●	●		●	●	
NJXB3-5	●			●	●	Fixed	●	●	○
NJXB3-6	●			Fixed	Fixed	●	●	●	○
NJXB3-7	●			●	●	●	●	●	○
NJXB3-8	●								●
NJXB3-9	●						●	●	●
NJXB3-10	●						●	●	
NJXB3-11		●	●	●				●	
NJXB3-12		●	●		●			●	
NJXB3-13		●	●	●	●			●	
NJXB3-14		●		●	●		●	●	
NJXB3-15		●		●	●	Fixed	●	●	○
NJXB3-16		●		Fixed	Fixed	●	●	●	○
NJXB3-17		●		●	●	●	●	●	○
NJXB3-18		●					●	●	○

Note: ● denotes available functions, ○ denotes optional functions.

3. Technical data

Model	Protection function	Protection operation time	Rated operational voltage	Contact capacity	Contact form	Usage category	Conventional heating current (I _{th})	Electrical life	Mechanical life
NJXB3	Overvoltage	0.1s~10s	Three-phase three-wire system: AC 380V 50Hz	Resistive load: AC250V 6A cosφ=1 Inductive load: AC250V 1A cosφ=0.4	1 N/O, 1 N/C	AC-15	3A	10 ⁵	10 ⁶
	Undervoltage								
	Three-phase voltage unbalance								
	Phase failure, phase sequence	≤1s	Three-phase four-wire system: AC 220V 50Hz						
	PTC temperature protection								

4. Wiring diagram

NJXB3-01, NJXB3-02, NJXB3-03, NJXB3-04, NJXB3-10
Wiring diagram

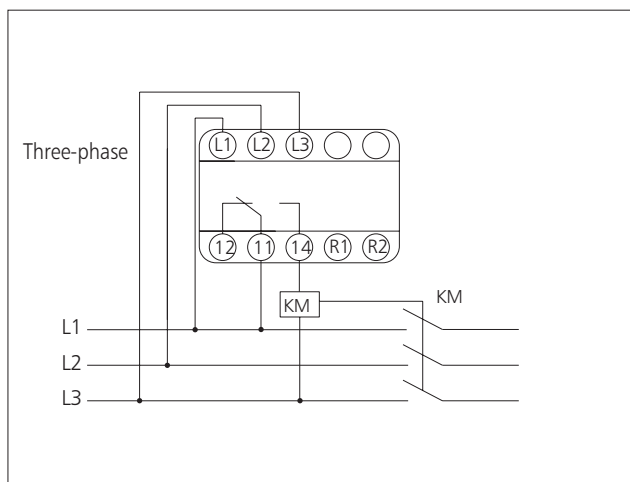

NJXB3-05(P), NJXB3-06(P), NJXB3-07(P), NJXB3-08(P), NJXB3-09
Wiring diagram

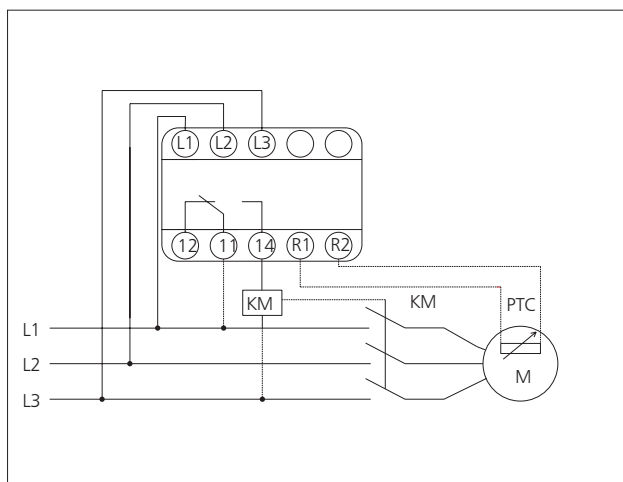

NJXB3-11, NJXB3-12, NJXB3-13 Wiring diagram

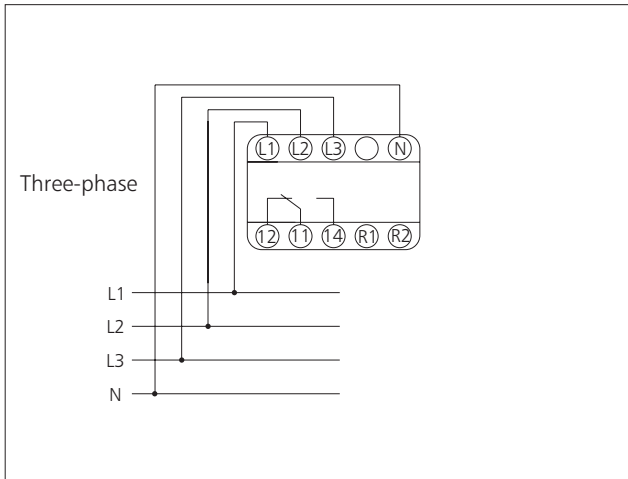

NJXB3 Wiring diagram

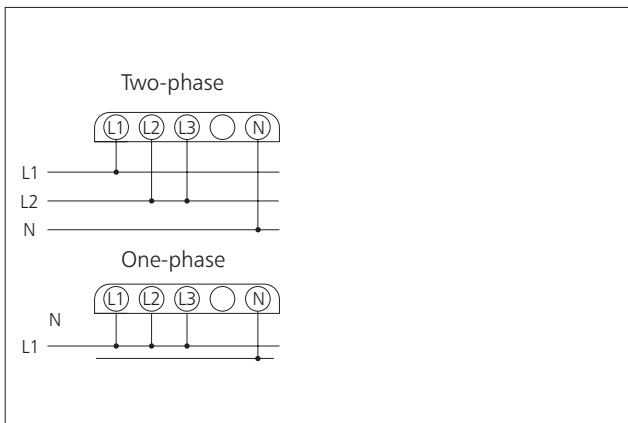

NJXB3-14, NJXB3-15(P), NJXB3-16(P), NJXB3-17(P), NJXB3-18 Wiring diagram

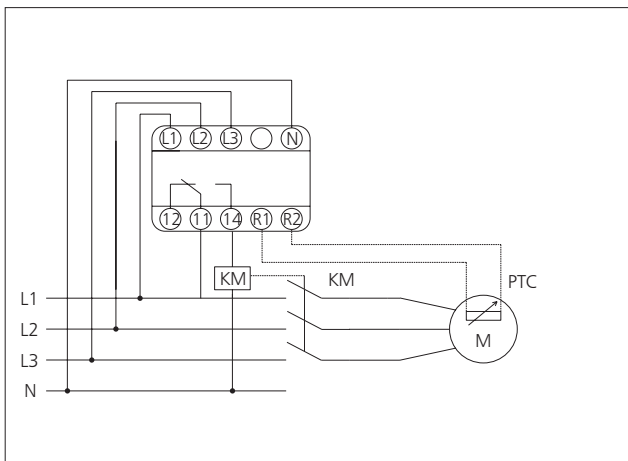

5. Overall and mounting dimensions (mm)

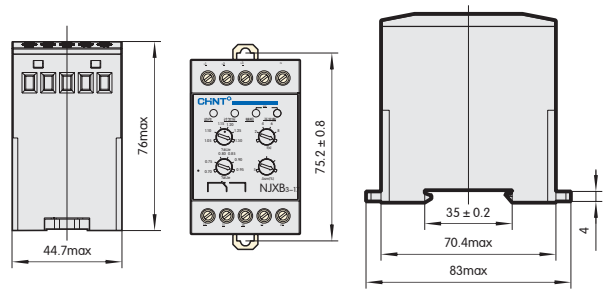

6. Installation and use

- 6.1 Connect the wires correctly in accordance with the connection diagram.
- 6.2 If the relay is of rail mounting type, use TH35-7.5 mounting rail.
- 6.3 If the relay is of installation mounting type, remove the limiter.



NJYB3 Relay

1. General

NJYB3 relay is used to provide overvoltage, undervoltage, phase failure, phase sequence and three-phase unbalance control in three-phase three-wire 380V circuits and three-phase four-wire 220V circuits with a frequency of AC 50Hz. For example, it is used for power control systems, air conditioning systems and motors.

This relay is a voltage protection relay. After detecting the voltage signal, the relay processes the input signal, judges if there is an overvoltage, undervoltage, phase failure, error-phase or unbalance and controls the operation accurately and stably by means of the built-in microprocessor.

2. Type designation

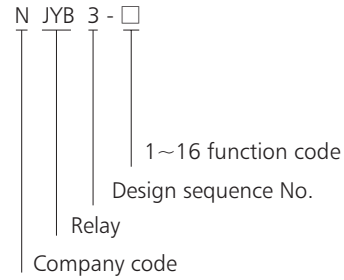

3. Technical data

Model	Protection function	Protection operation time	Rated operational voltage	Contact capacity	Contact form	Usage category	Conventional heating current (Ith)	Electrical life	Mechanical life
NJYB3	Overvoltage	0.1s~10s	Three-phase three-wire system: AC 380V 50Hz	Resistive load: AC250V 6A cosφ=1 Inductive load: AC250V 1A cosφ=0.4	1 N/O, 1 N/C	AC-15	3A	10 ⁵	10 ⁶
	Undervoltage								
	Three-phase voltage unbalance								
	Phase failure, phase sequence	≤1s	Three-phase four-wire system: AC 220V 50Hz						

Model	Three-phase three-wire	Three-phase four-wire	Single-phase/two-phase	Overvoltage protection	Undervoltage protection	Unbalance protection	Phase sequence protection	Phase failure protection
NJYB3-1	●						●	●
NJYB3-2	●			●				●
NJYB3-3	●				●			●
NJYB3-4	●			●	●			●
NJYB3-5	●			●	●		●	●
NJYB3-6	●			●	●	Fixed	●	●
NJYB3-7	●			Fixed	Fixed	●	●	●
NJYB3-8	●			●	●	●	●	●
NJYB3-9		●	●	●				●
NJYB3-10		●	●		●			●
NJYB3-11		●	●	●	●			●
NJYB3-12		●		●	●		●	●
NJYB3-13		●		●	●	Fixed	●	●
NJYB3-14		●		Fixed	Fixed	●	●	●
NJYB3-15		●		●	●	●	●	●
NJYB3-16		●					●	●

Note: ● denotes available functions, ○ denotes optional functions.

Basic data of auxiliary circuit

Contact form	Conventional heating current I _{th} (A)	Usage category	Rated operational voltage U _e (V)	Rated operational current U _e (A)
1 group of change-over contacts	3	AC-15	220	0.75
			380	0.47

Immunity

Item	Severity level
Electrostatic discharge immunity	8×(1±10%)kV (air discharge)
Radiated electromagnetic field immunity	Test electric field strength: 10×(1±10%)V/m
Fast transient immunity	For power line, 2×(1±10%)kV, duration: 1min
Surge (impact) immunity	Open circuit test voltage: 2×(1±10%)kV

4. Wiring diagram

NJYB3-01, NJYB3-02, NJYB3-03, NJYB3-04, NJYB3-05, NJYB3-06, NJYB3-07, NJYB3-08 Wiring diagram

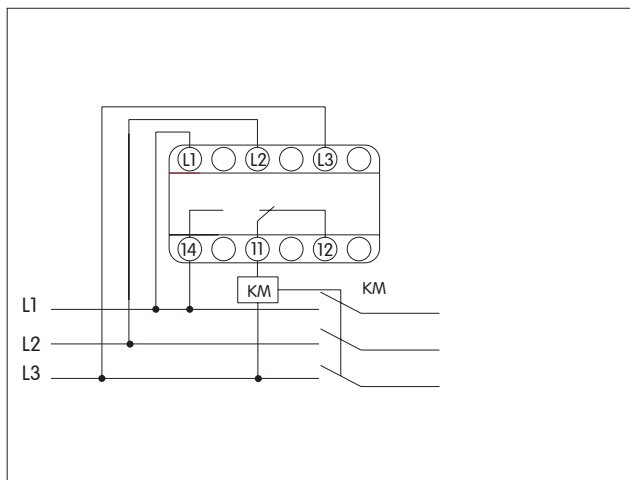

NJYB3-12, NJYB3-13, NJYB3-14, NJYB3-15, NJYB3-16 Wiring diagram

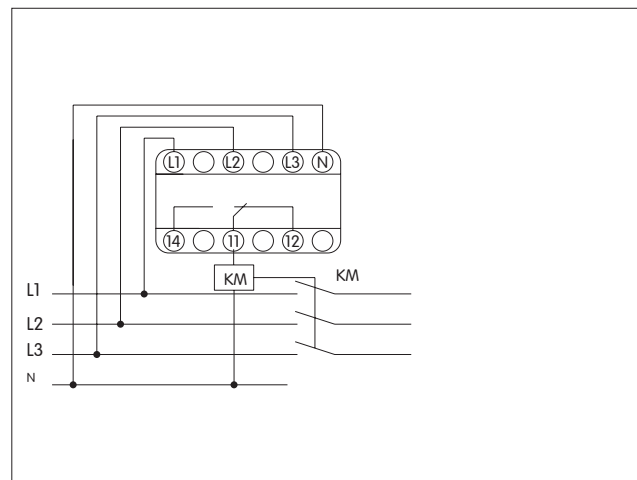

NJYB3-9, NJYB3-10, NJYB3-11 Wiring diagram

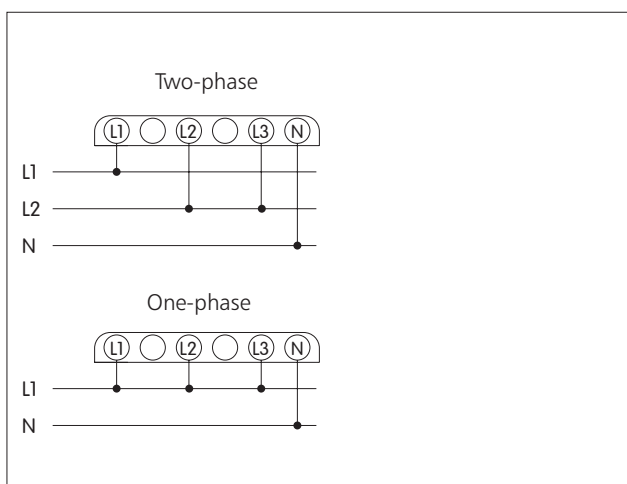
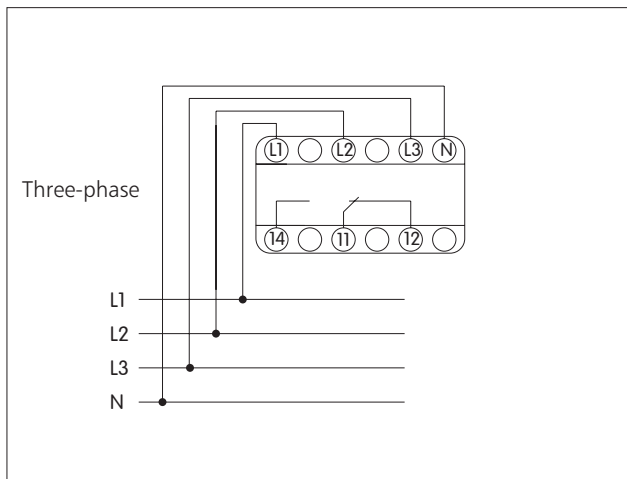

5. Overall and mounting dimensions (mm)

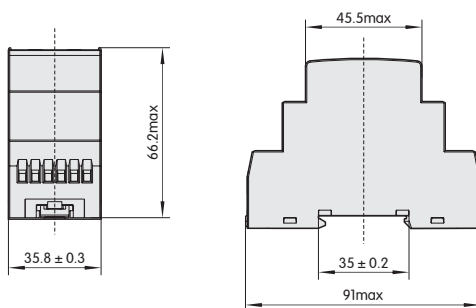



JD-5A(NJBK3) Integrated Motor Protector

1. General

JD-5A(NJBK3) Integrated Motor Protector (hereinafter referred to as protector) is applicable for overload, phase-failure and three-phase current unbalance protection of AC motor @ A.C.50Hz, less than AC400V rated operating voltage and 1A~400A rated operating current for its continuous working or discontinuous working. Protector and AC contactor are generally used cooperatively. This product meets the requirements of IEC 60947-4-1.

2. Type designation

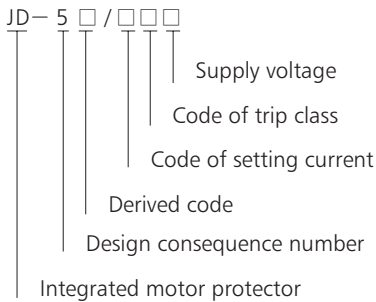

3. Operation conditions

- 3.1 Altitude ≤2000m.
- 3.2 Ambient temperature Range:-15°C~ +55°C, with daily average≤+50°C.
- 3.3 Atmospheric condition: when the highest temperature is +40°C, relative humidity of air shall be no more than 50%, higher relative humidity shall be allowable at lower temperature, for instance air humidity may reach 90% at +20°C. As for dews, which contingently appear due to change of temperature, special steps should be taken
- 3.4 Pollution Level: Level 3.
- 3.5 Inclination between installation plane and vertical plane shall ≤±5°.
- 3.6 At places without explosive risk, without gases that may be corrosive to metal or gases that may cause damage to the insulation, and with little conducting dust.
- 3.7 At places where rain & snow proof facilities are equipped with and not being full of steam.
- 3.8 At places without prominence rock, impact and vibration.
- 3.9 Installation Category: III.

4. Technical data

Table 1

Type	Setting current range (A)	Voltage of control power supply (Supply Voltage) (V)	Suitable motor power (kW)
JD-5A/80	1~5	220V, 230V, 380V, 400V	0.5~2.5
JD-5A/80	5~20	220V, 230V, 380V, 400V	2.5~10
JD-5A/80	20~80	220V, 230V, 380V, 400V	10~40
JD-5A/400	80~200	220V, 230V, 380V, 400V	40~100
JD-5A/400	160~400	220V, 230V, 380V, 400V	80~200

Control circuit: rated insulation voltage AC380V, rated frequency 50Hz, contact parameters refer to Table 2.

Table 2

Use type	AC-15	
Rated operating voltage (V)	240	380
Rated operating current (A)	1.5	0.95
Conventional thermal current (A)	5	

5. Design features

- 5.1 Three-phase electronic type, trip class is level 10A, 10, 20 and 30.
- 5.2 Equipped with function of phase-failure, overload and three-phase unbalance protection.
- 5.3 Digital dial-up setting with high precision
- 5.4 Digital current display.
- 5.5 Three indicators indicate normal, overload and phase-failure (three-phase current unbalance) status respectively.
- 5.6 Main circuit adopts feed-through wiring.
- 5.7 Installation mode: bolts

6. Protection features

- 6.1 Operation characteristics under phases balanced-load status (see Table 3)
- 6.2 Operation characteristic under phase-failure status
Operation characteristic under phase-failure status should meet the requirement: operation time of protector ≤5s

$$\frac{I_{max}-I_{min}}{I_{max}} \times 100\% > 40\%$$

Where:

I_{max}---max current value among three phase current;
I_{min}---min current value among three phase current.

6.3 Tripping feature

Figure 1

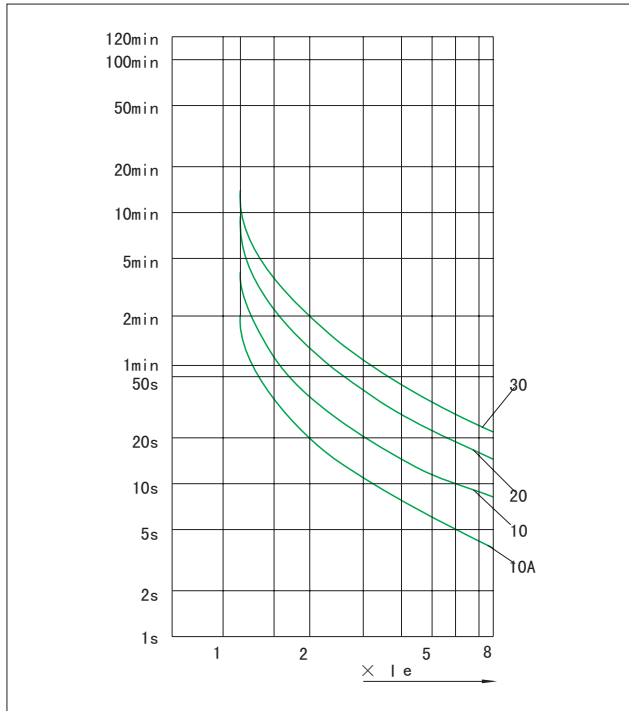

S.N	I/In	Trip class	Operation time	Test condition	Ambient temperature
1	1.05	10A	<2h non-tripping	start from cold status	
		10			
		20			
2	1.2	10A	<2h tripping	Right after item No.1	20±2
		10			
		20			
3	1.5	10A	<2min	Start after putting one time of setting current through main circuit for 2h	
		10	<4min		
		20	<8min		
		30	<12min		
4	7.2	10A	2s<Tp≤10s	start from cold status	
		10	4s<Tp≤10s		
		20	6s<Tp≤20s		
		30	8s<Tp≤30s		

6.4 Reset mode: De-energizing reset

7. Wiring diagram

7.1 See Figure 2 for wiring diagram of control power supply @ AC220V/AC230V voltage.

Figure 2

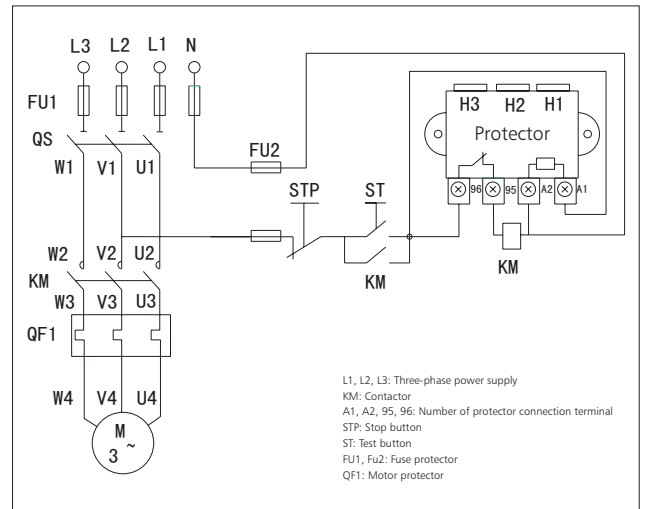

7.2 See Figure 3 for wiring diagram of control power supply @ AC380V/AC400V voltage.

Figure 3

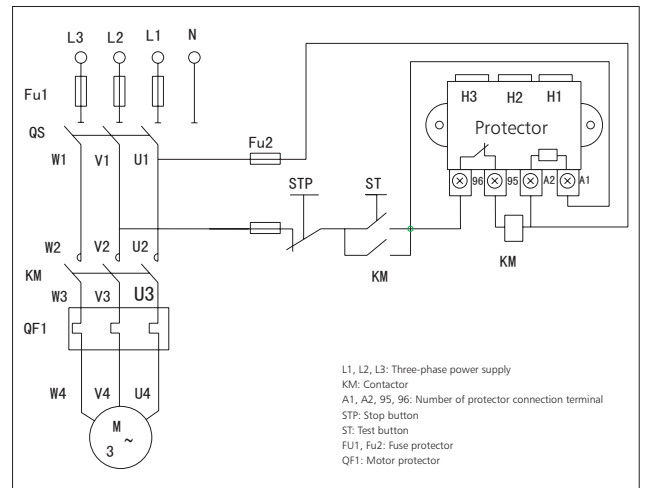

8. Overall and mounting dimensions (mm)

JD-5/80

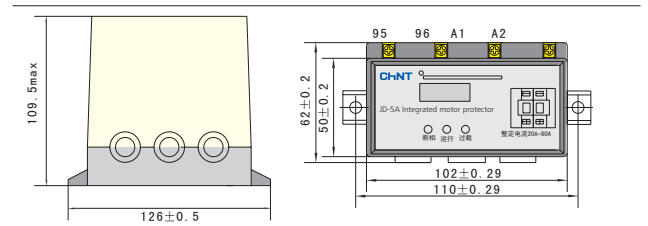

JD-5/400

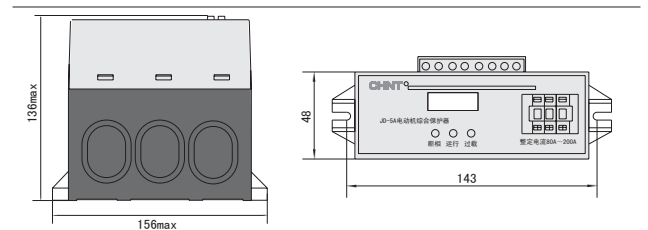

9. Ordering information

9.1 Designation and type-specification of protector, select controlling current and voltage (AC220V, AC230V, AC380V, AC400V), setting current range (1A~5A, 5A~20A, 20A~80A, 80A~200A, 160A~400A), Trip class (10A, 10, 20, 30) according to operating requirements. Trip class in routine order is level 10.

9.2 Order Quantity.



JD-5 Motor Integrated Protector

1. General

JD-5 Motor Integrated Protector (hereinafter referred to as protector) is applicable for overload and phase-failure protection of AC motor @ A.C.50Hz, less than AC400V rated operating voltage and 0.5A~400A rated operating current for its continuous working or discontinuous working. Protector and AC contactor are generally used cooperatively. This product meets the requirements of GB 14048.4 and IEC 60947- 4-1.

2. Type designation

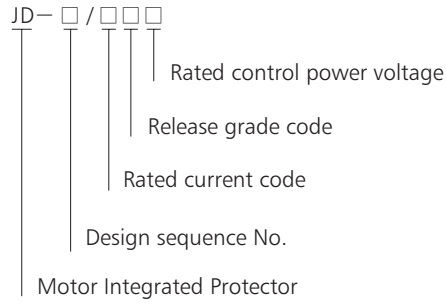

3. Operation conditions

- 3.1 Altitude ≤2000m.
- 3.2 Ambient temperature Range: -5℃ ~ +40℃, with daily average ≤ +35℃.
- 3.3 Atmospheric condition: when the highest temperature is +40℃, the relative humidity of air shall be no more than 50%, higher relative humidity shall be allowable at lower temperature, for instance air humidity may reach 90% at +20℃. As for dews, which contingently appear due to change of temperature, special steps should be taken.
- 3.4 Pollution Level: Level 3.
- 3.5 Inclination between installation plane and vertical plane shall ≤ ±5°.
- 3.6 In the media without explosive risk, and no gases that may be corrosive to metal and damage insulation in the media together with at places where much conducting dust being in existence.
- 3.7 At places where rain & snow proof facilities are equipped with and not being full of steam.
- 3.8 At places without prominence rock, impact and vibration.
- 3.9 Installation Category: III.

4. Technical data

4.1 Rated insulation voltage AC690V, rated frequency 50Hz, rated operating current 0.5A ~ 400A.

Table 1

Type	Setting current range (A)	Voltage of control power supply (Supply Voltage) (V)	Suitable motor power (kW)
JD-5/80	0.5~5	220V, 230V, 380V, 400V	0.25~2.5
JD-5/80	2~20	220V, 230V, 380V, 400V	1~10
JD-5/80	20~80	220V, 230V, 380V, 400V	10~40
JD-5/400	80~200	220V, 230V, 380V, 400V	40~100
JD-5/400	160~400	220V, 230V, 380V, 400V	80~200

4.2 Control circuit: rated insulation voltage Ac380v, rated frequency 50Hz, contact parameters refer to Table 2.

Table 2

Use type		AC-15	
Rated operating voltage (V)	220		380
Rated operating current (A)	1.5		0.95
Conventional thermal current (A)		5	

5. Design features

- 5.1 Three-phase electronic type, tripping grade (trip class): 10A.
- 5.2 Equipped with function of phase-failure and overload protection.
- 5.3 Equipped with continuously adjustable device for setting current.
- 5.4 Three indicators indicate normal, overload and phase-failure status respectively.
- 5.5 Main circuit adopts feed through wiring.
- 5.6 Installation mode: use bolts for installation.

6. Protection features

6.1 Operation characteristics under three-phase balanced-load status (see Table 3)

Table 3

S.N.	I/In	operating time	Test Condition	Ambient temperature
1	1.05	<2h non-tripping	Cold Status	+20°C
2	1.20	<2h tripping	Hot Status	
3	1.50	<2 min tripping		
4	7.20	2s<Tp≤10s	Cold Status	

6.2 Operation characteristic under phase-failure status (see Table 4)

Table 4

S.N.	Multiple of setting current		operating time	Test Condition	Ambient temperature
	Any two phases	The Third phases			
1	1.0	0.9	<2h non-tripping	Cold Status	+20°C
2	1.15	0	≤5s	Hot Status	

6.3 Tripping feature

Figure 1

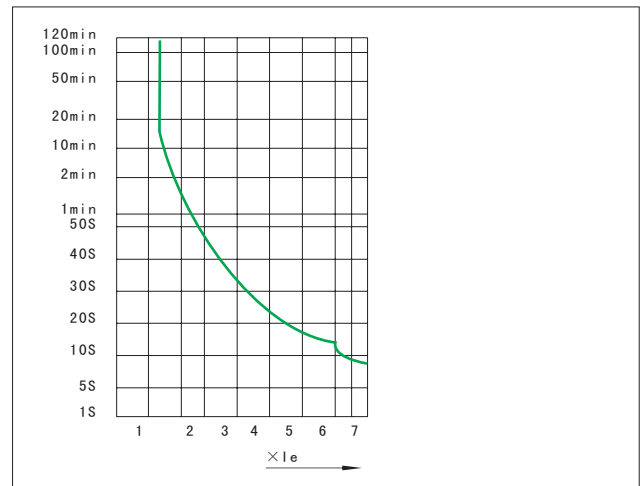

6.4 Reset mode: de-energizing reset

7. Wiring diagram

7.1 Wiring diagram for control power supply @ AC220V/AC230V voltage

Wiring diagram for control power supply @ AC230V voltage

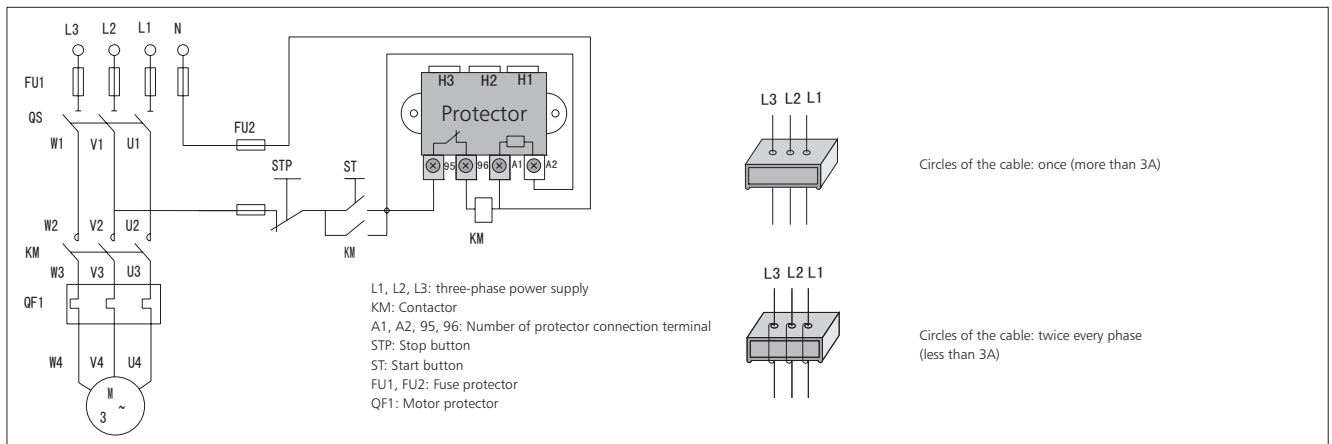

7.2 Wiring diagram for control power supply @ AC380V/AC400V voltage

Wiring diagram for control power supply @ AC400V voltage

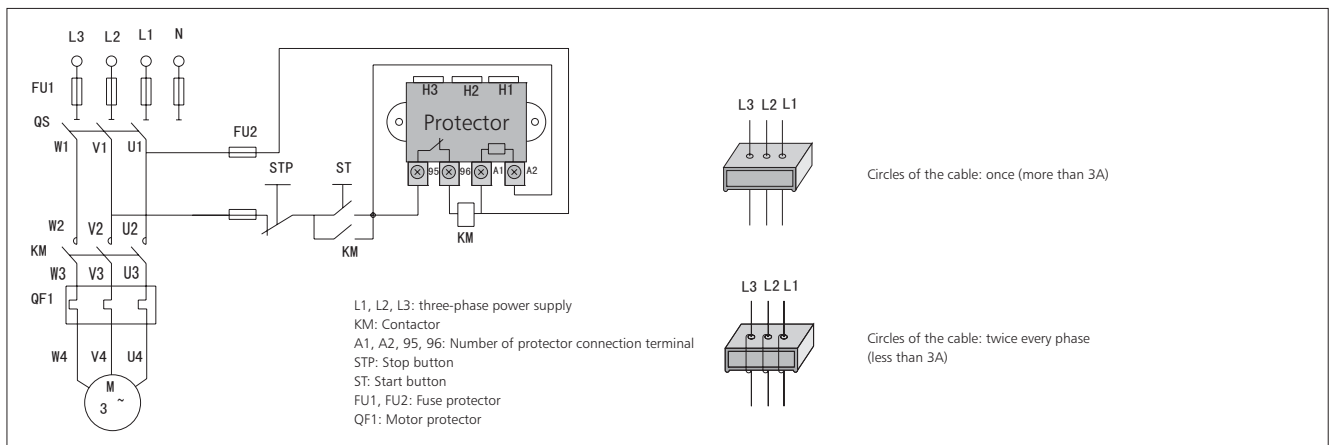

8. Overall and mounting dimensions (mm)

JD-5/80

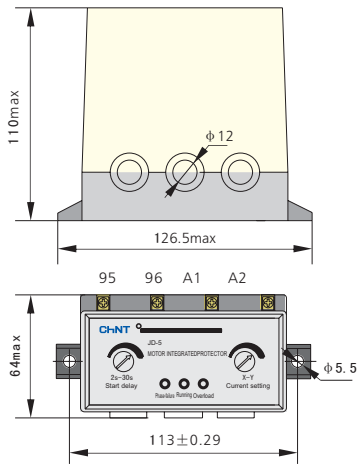

JD-5/400

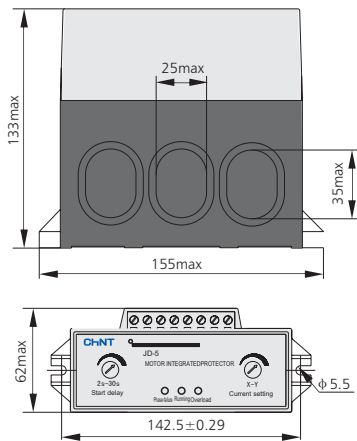

9. Ordering instructions

9.1 Designation, type and specification of protector, select controlling current and voltage (AC220V, AC230V, AC380V, AC400V), setting current range (0.5A~5A, 2A~20A, 20A~80A, 80A~200A 160A~400A, etc) according to operating requirements.

9.2 Order Quantity.



NJYB1 Phase-Failure and Phase-Sequence Protection Relay

1. General

This product is applicable in operating console of facilities for motor protection, circuit protection and controlling large size motor. It can detect fault state as overvoltage, undervoltage, phase-failure and phase-sequence through advanced electronic circuit check, and provide reliable protection.

2. Type designation

2.1 Model and meaning

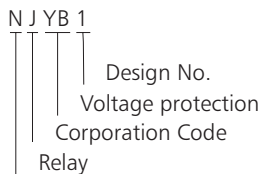

2.2 Technical parameters

2.2.1 Fundamental parameter

- Overvoltage protection: $(1.0-1.3) U_e$; undervoltage protection: $(0.7-1.0) U_e$.
- Fault protection time: 0.1 9.9s.
- Dielectric strength: there is no breakdown and flicker appeared for alternating current (50Hz) lasting a period of time of 1 s. under 2000V.
- Insulation resistance: $>100M$ (relative humidity at $20^\circ C$ is 90%).
- Contact capacity: AC-15 220V 1A.
- Contact resistance: 0.03Ω .
- Contact life: life should $\geq 100,000$ times.
- Ambient temperature: $-10^\circ C \sim +50^\circ C$.
- Ambient humidity: $\leq 8\%$ ($20^\circ C \sim +5^\circ C$).
- Installation mode: 35mmC guide rail installation

2.3 Performance feature

S.N.	Fault type	Reacting time		Ambient air humidity
		Specified time	Inverse time	
1	Overvoltage protection	0.1 ~ 9.9s	$T_r = (U_{on}/U_r)^2 \times T_n$	Room temperature
2	Undervoltage protection	0.1 ~ 9.9s	$T_r = (U_r/U_{un})^2 \times T_n$	
3	Phase-Failure protection	$\leq 0.1s$		
4	Phase-sequence protection	$\leq 0.1s$		

2.4 Time-voltage feature of voltage protector

Time-voltage feature of voltage protector

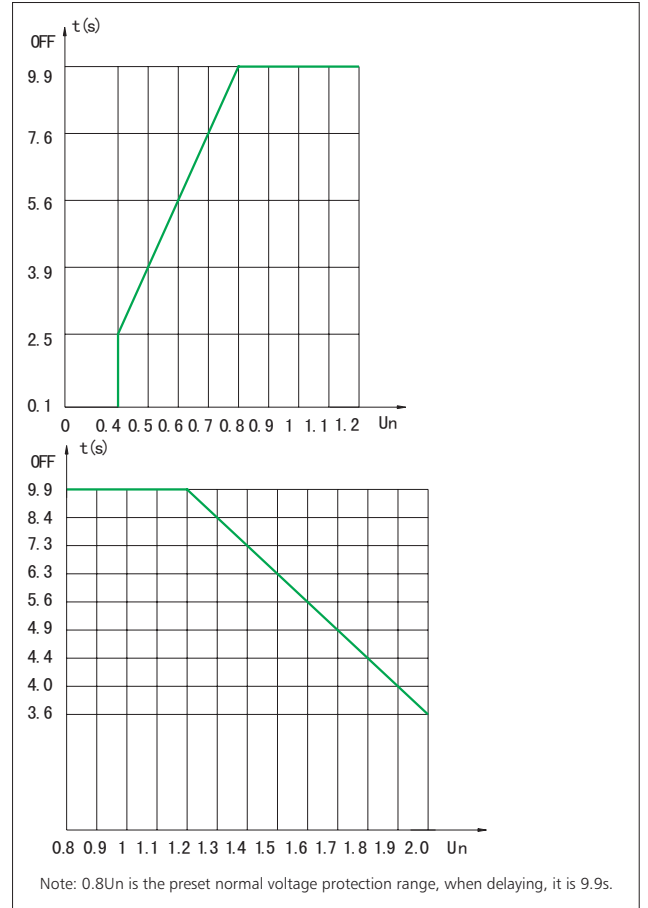

3. Wiring diagram

Wiring diagram for voltage protector

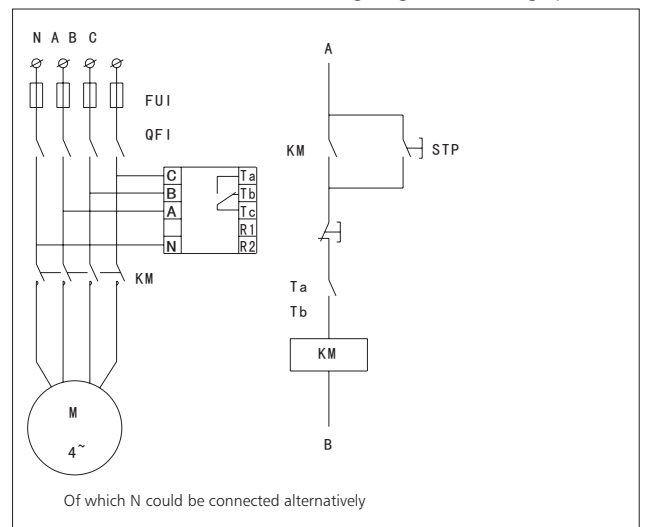



XJ3 Phase-Failure and Phase-Sequence Protective Relay

1. General

XJ3 series phase failure and phase sequence protection relay is used to provide overvoltage, undervoltage and phase failure protection in three-phase AC circuits and phase failure protection in irreversible transmission devices and features reliable performance, wide application and convenient use.

The protector starts to function when it is connected to the power control circuit in accordance with the drawing. When the fuse of any phase of the three-phase circuit is open or when there is a phase failure in the power supply circuit, the XJ3 operates immediately to control the contact to cut off the power supply of the AC contactor coil of the main circuit so that the main contact of the AC contactor operates to provide the load with phase failure protection.

When the phases of a three-phase irreversible device with predetermined phase sequence are connected incorrectly due to maintenance or change of the power supply circuit, the XJ3 series will identify the phase sequence, stop supplying power to the power supply circuit and achieve the goal of protecting the device.

2. Type designation

XJ 3 - □ / □

- Rated power supply voltage
- Remodel (derived model)
- G: monochrome luminotron fault indication type;
- S: two-color luminotron fault indication type;
- D: multifunction protection, multimode indication type
- Design sequence No.
- Phase-failure and phase-sequence protective relay

3. Technical data

Type	XJ3-G	XJ3-S	XJ3-D
Protection function	Phase-failure Phase-sequence error & Three phase voltage unbalance $\geq 8\% \sim 13\%$		Overvoltage Undervoltage Phase-failure Phase-sequence error
Overvoltage protection			AC 380V: 380V~460V 1.5s~4s (adjustable) 300V~380V 2s~9s(adjustable) AC 400V: 320V~400V 1.5s~4s (adjustable) 400V~480V 2s~9s(adjustable)
Undervoltage protection			
Operating voltage	AC 380V 50Hz/60Hz, Allowable fluctuating range $\pm 10\%$		
Contact number	1 normally open & 1 normally close		1 group changeover
Contact capacity	5A 230VAC $\cos \phi = 1$		3A 230VAC $\cos \phi = 1$
Phase-failure and phase-sequence protection	Reacting time $\leq 2s$		
Electrical life	1×10^5		
Mechanical life	1×10^6		
Ambient temperature	$-5^{\circ}\text{C} \sim 40^{\circ}\text{C}$		
Ambient humidity	$-5^{\circ}\text{C} \sim 40^{\circ}\text{C}$		
Installation mode	Equipment type or Track type		35mm Track installation or punching installation

Note: in the example diagram for application circuit, protective relay can provide protection only under the condition of phase-failure occurring at terminal 1, 2, 3 and among three phase of power supply A, B, C.

4. Wiring diagram

XJ3-G, S wiring diagram

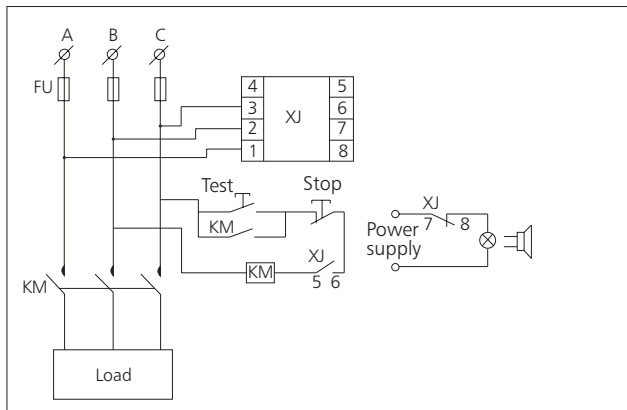

XJ3-D wiring diagram

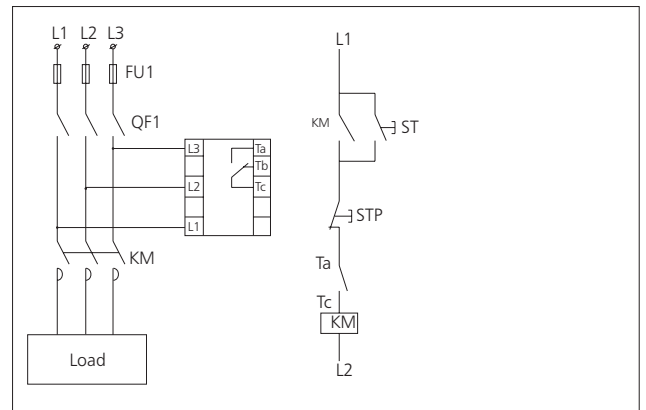

5. Overall and mounting dimensions (mm)

XJ3-G, S profile and installation dimension

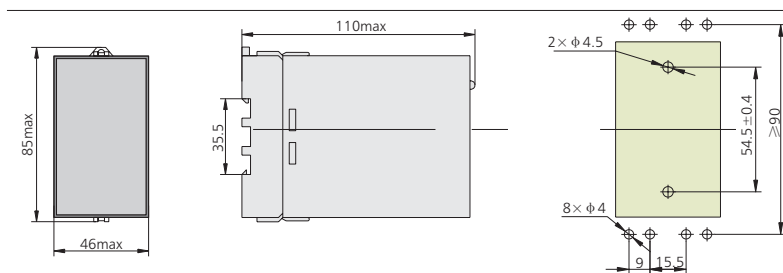

XJ3-D profile and installation dimension

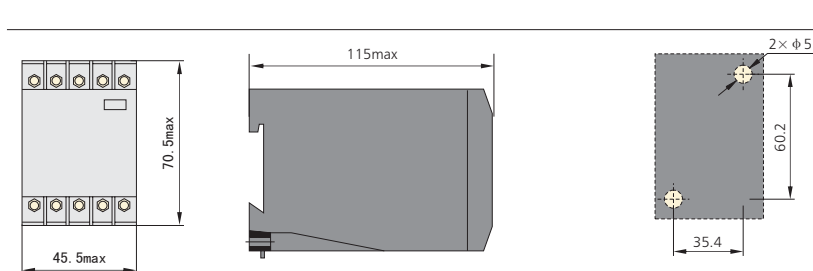



NJS6 Time Delay Relay

1. General

NJS6 series time delay relay (hereinafter referred to as relay) is used as a time control element in control circuits with an AC voltage of 240V or below and a frequency of 50Hz and control circuits with a DC voltage of 240V or below to make and break the circuit according to the schedule.

2. Type designation

N JS 6 / □

| | |
 | | |
 | | | Rated control supply voltage
 | | | Design sequence No.
 | | | Time delay relay
 | | | Company code

3. Technical data

Mode	NJS6
Operating mode	On-delay (OND, OND1), trigger delay (OND2), On-off repetitive delay (FLY), interval delay (INT, INT1), optional
Number of contacts	Delay 1 change-over
Contact capacity	Ue/Ie: AC-15 220V/0.75A, 380V/0.47A; DC-13 220V/0.27A; Ith:5A
Solid state output	NPN solid state delay 1 output
Solid state output capacity	Max 30VDC Max 100mA
Operational voltage	AC/DC100~240V 50Hz DC24V
Electrical life	1×10^5
Mechanical life	1×10^6
Delay accuracy	Start timing from power on: $\pm 0.01\% \pm 0.05s$, start timing from signal ON: $\pm 0.01\% \pm 0.03s$
Timing mode	Addition or subtraction timing mode, optional
Contact output time	The output contacts have automatic reset function. The contact output time is 10, 50, 100, 200, 500, 1000, 2000, 5000 or Hold, optional. (in ms)
Ambient temperature	-5°C ~ +40°C
Mounting type	Panel type
Delay range	For single product, 99.99s/999.9s/9999s/99min59s/999.9min/9999min/99h99min/9999h, optional

4. Wiring diagram

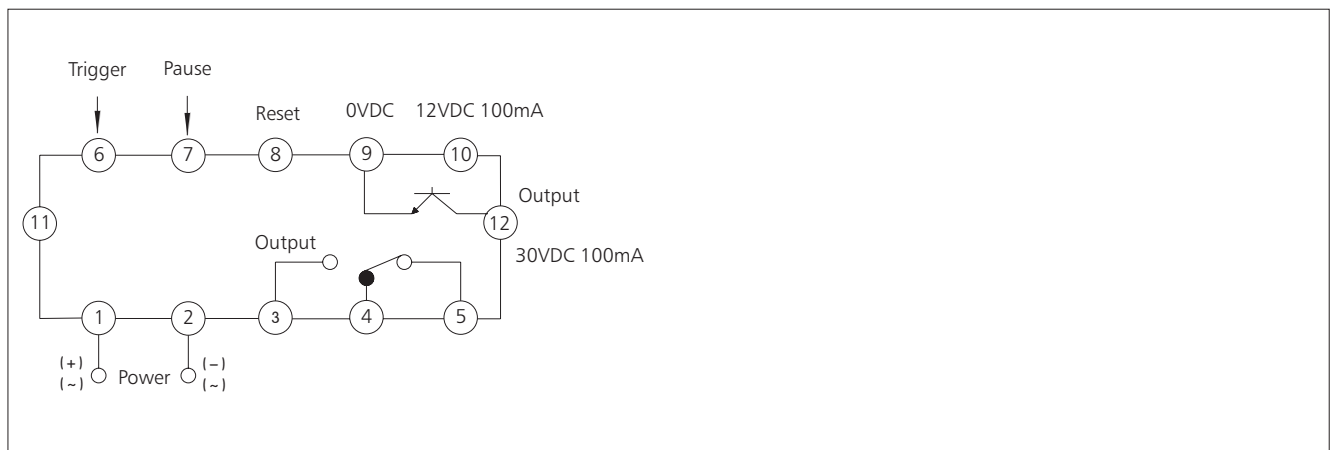

5. Overall and mounting dimensions (mm)

Profile and installation dimension

Opening size

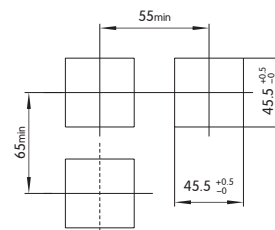
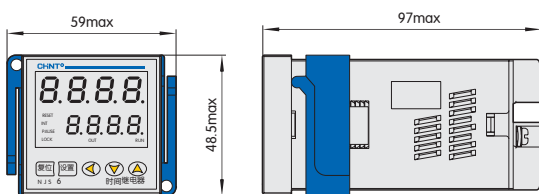

6. Profile and installation dimension

Output mode	Timing-sequence diagram
<p>On delay $\square \square \square$</p>	<p>POWER ON DELAY(countingresetswhenpowerOFF)</p>
<p>On delay $\square \square \square \square$</p>	<p>POWER ON DELAY(countingcontinueswhenpowerOFF)</p>
<p>Trigger delay $\square \square \square \square$</p>	<p>SIGNAL ON DELAY1(resetswhenpowerOFF)</p>
<p>Loop delay $\square \square \square \square$</p>	<p>FLICKER(resetswhenpowerOFF)</p>

Output mode	Timing-sequence diagram
-------------	-------------------------

Interval delay t_{INT}

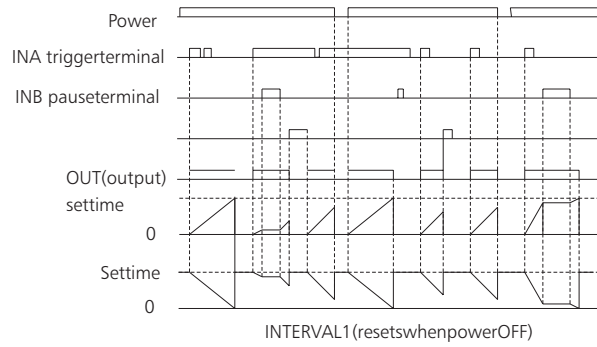

Interval delay t_{INT}, t

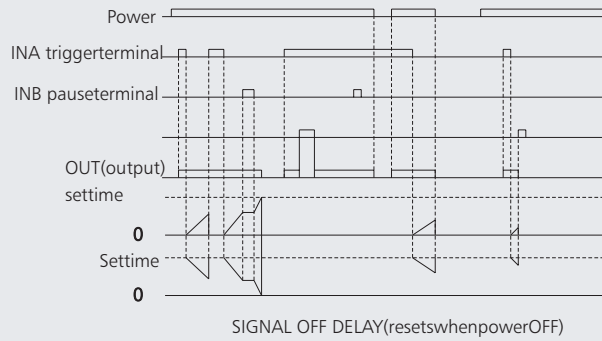

Note

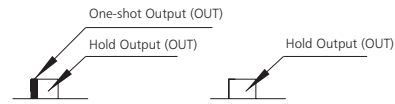



NJS2 Time Delay Relay

1. Application scope

NJS2 Series Time Relay is applicable for controlling circuit @ A.C. 50Hz/60Hz, up to 240V rated supply voltage and up to D.C. 240V rated supply voltage as delay element to make or break circuit according to preset time.

2. Model and meaning

N JS 2 / □

- Rated control supply voltage
- Design S.N.
- Time-delay relay
- Enterprise feature code

Note: this product is applicable for wide range operating voltage, for instance, operating voltage within AC/DC100V~240V means it can operate normally within the voltage range of AC/DC 100V to 240V.

3. Technical data

Operating mode	(power) on delay (OND, OND1), trigger-delay (OND2), reciprocate-delay (FLY), interval-delay (INT, INT1) are available for option
Contact number	Delay 1 changeover
Contact capacity	Ue/Ie:AC-15 220V/0.75A; DC-13 220V/0.27A; Ith:5A
Solid-state output	NPN solid-state delay 1 output
Solid-state output capacity	Max 30VDC max 100mA
Operating voltage	AC36V, AC/DC100V~240V 50Hz/60Hz
Electrical life	1×10^5
Mechanical life	1×10^6
Delay precision	Power supply ON start timing: $\leq \pm 0.01\% \pm 50\text{ms}$ Signal ON start timing: $\leq \pm 0.01\% \pm 30\text{ms}$
Timing mode	Plus & minus timing mode are available for option
Contact output time	Contact output is equipped with function of automatic reset, contact output time 10, 50, 100, 200, 500, 1000, 2000, 5000, and Hlod are available for option (unit: ms)
Ambient temperature	-5°C ~ +40°C
Installation mode	Panel type

Delay range

Type	99.99s, 999.9s, 9999s, 99min59s, 999.9min, 9999min, 99h59min, 9999h are optional for each product
-------------	--

4. Wiring diagram

NJS2 Wiring diagram

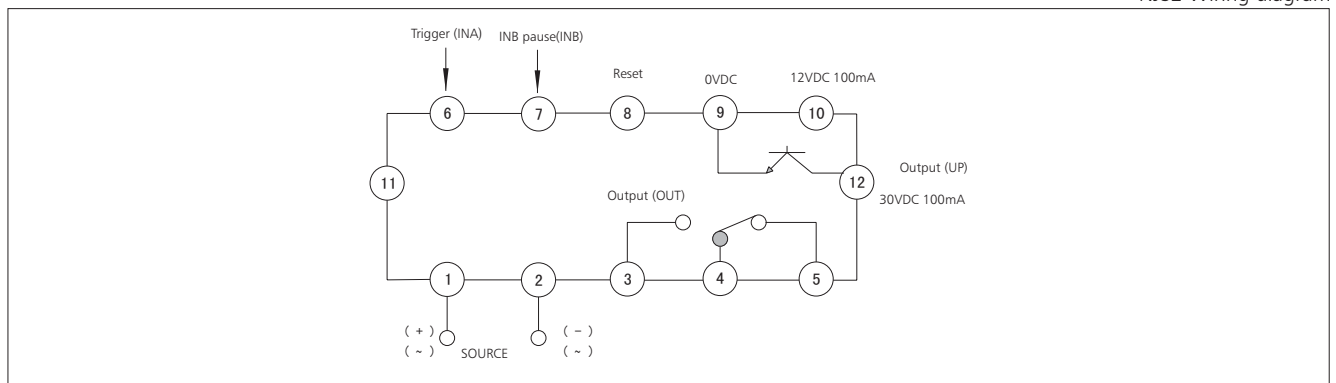

5. Overall and mounting dimensions (mm)

Profile and installation dimension

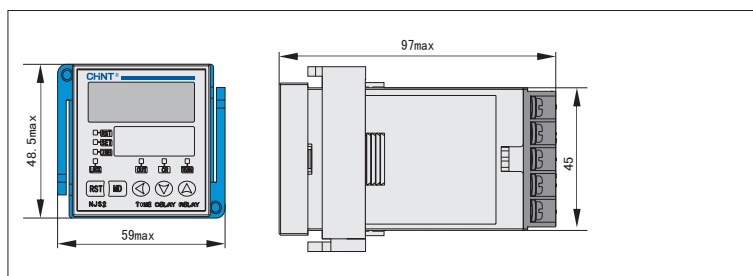

Opening size

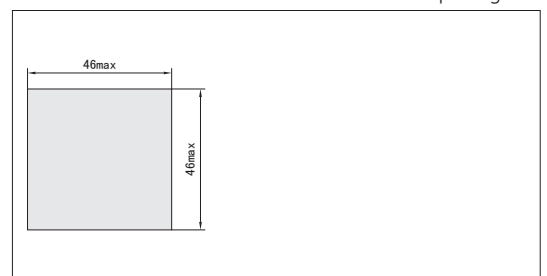

6. Profile and installation dimension

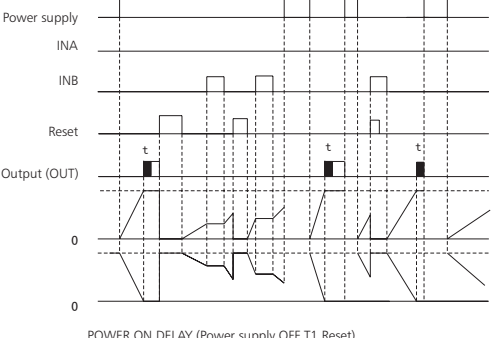
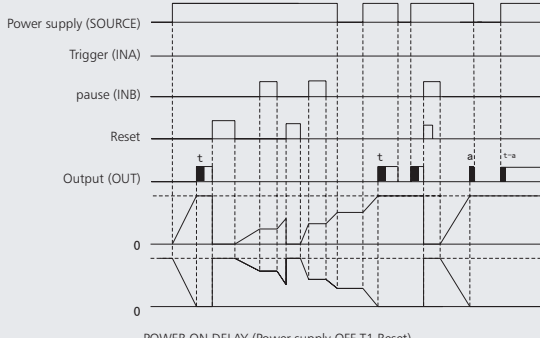
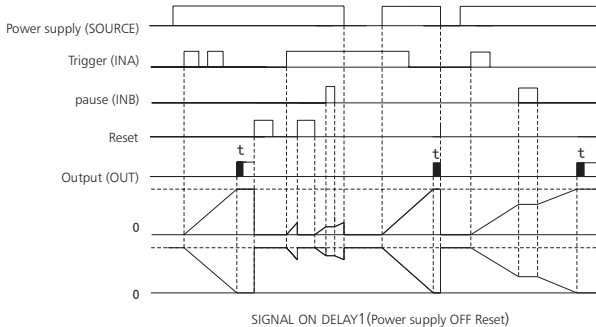
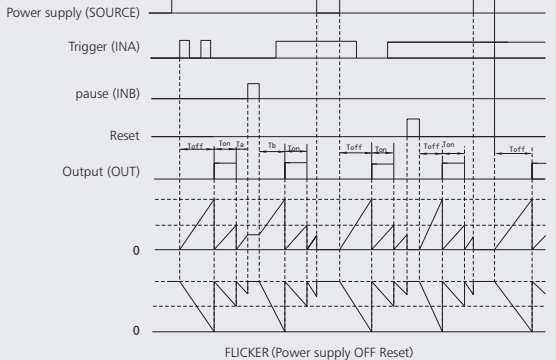
Output mode	Timing-sequence diagram
<p>(power) on delay OND</p>	 <p>POWER ON DELAY (Power supply OFF T1 Reset)</p>
<p>(power) on delay OND_1</p>	 <p>POWER ON DELAY (Power supply OFF T1 Reset)</p>
<p>Trigger-delay OND_2</p>	 <p>SIGNAL ON DELAY1 (Power supply OFF Reset)</p>
<p>Circulation-delay FLK</p>	 <p>FLICKER (Power supply OFF Reset)</p>

Output mode

Timing-sequence diagram

Interval-delay | $n \cdot t_1$ |

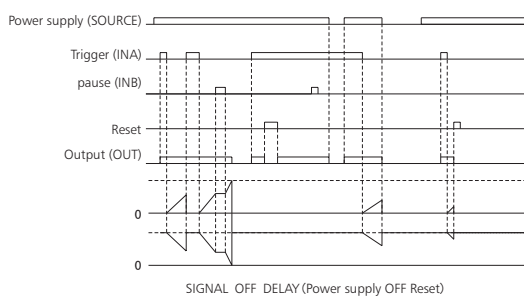

Interval-delay | $n \cdot t_1$ |

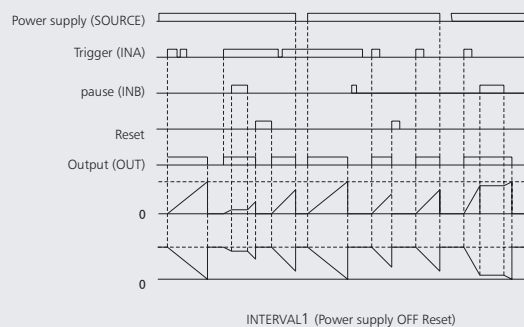

Note

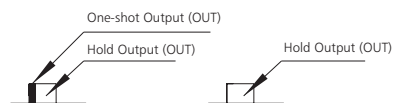



NJS1 Time Delay Relay

1. General

NJS1 Series Time-Delay Relay is applicable for controlling circuit @ A.C. 50Hz/60Hz, up to 380V rated voltage or up to D.C.220V rated voltage as delay element to make or break circuit according to preset time.

2. Type designation

NJS-1□□/□□

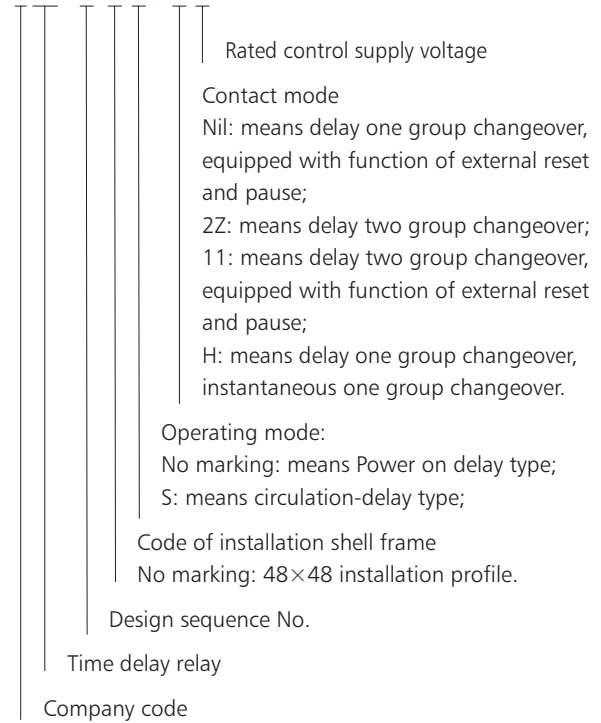

Note: this product is applicable for wide range operating voltage, for instance, operating voltage within AC/DC24V~48V means it can operate normally within the voltage range of AC/DC 24V to 48V.

3. Technical data

Type	NJS1	NJS1-ZZ	NJS1-11	NJS1-H	NJS1-S						
Operating mode	power on delay	power on delay	power on delay	power on delay	Circulation-delay						
Contact number	Delay 1 changeover	Delay 2 changeover	Delay 2 changeover	Delay 1 changeover Instantaneous 1 changeover	Delay 1 changeover						
Contact capacity	Ue/Ie:AC-15 220V/0.75A,380V/0.47A; DC-13 220V/0.27A; Ith:5A										
Turn-on (Power) on delay type Delay range	Time-base code	0.01s	0.1s	s	10s	$\frac{m}{s}$	0.1m	m	$\frac{h}{m}$	0.1h	h
	Setting range	0.01S~99.99s	0.1S~999.9s	1S~9999s	10S~99990s	1S~99min99s	0.1min~999.9min	1min~9999min	1min~99h99min	0.1h~999.9h	1h~9999h
Circulation-delay type Delay range	Time-base code	0.1s	1s	0.1min	1min	0.1h	1h	10h			
	Setting range	0.1S~9.9s	S~99s	0.1min~9.9min	1min~99min	0.1h~9.9h	1h~99h	10h~990h			
Operating voltage	AC/DC: 24~48V,100V~240V, AC220V, AC380V										
Repeat pause function	Have	N/A	Have	N/A	Have						
Electrical life	1×10^5										
Mechanical life	1×10^6										
Delay precision	$\leq 1\%$										
Ambient temperature	$-5^{\circ}\text{C} \sim +40^{\circ}\text{C}$										
Power consumption	$\leq 3\text{VA}$										
Installation mode	Panel type, Device type										
Matched pedestal	Panel type CZS08S, CZS11S, CZS08G, CZS11G, Device type CZS08C, CZS11C										

4. Wiring diagram

NJS1-ZZ Wiring diagram

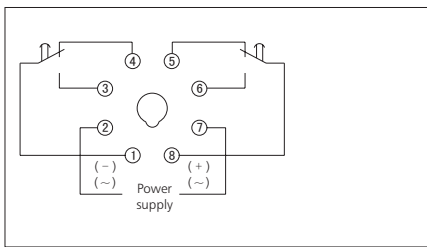

NJS1 Wiring diagram

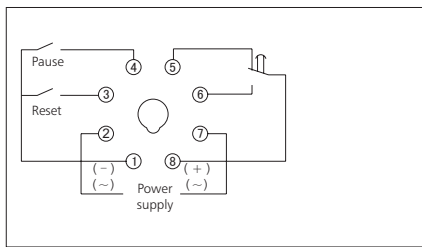

NJS1-S Wiring diagram

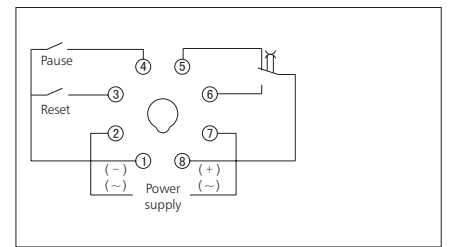

NJS1-11 Wiring diagram

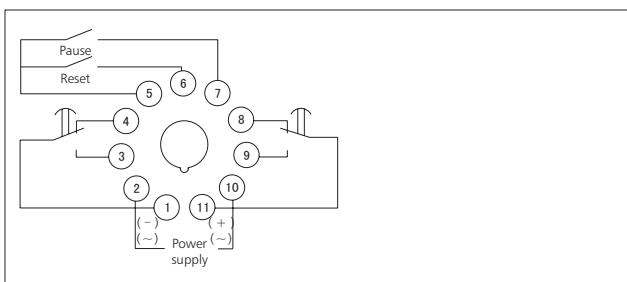

NJS1-H Wiring diagram

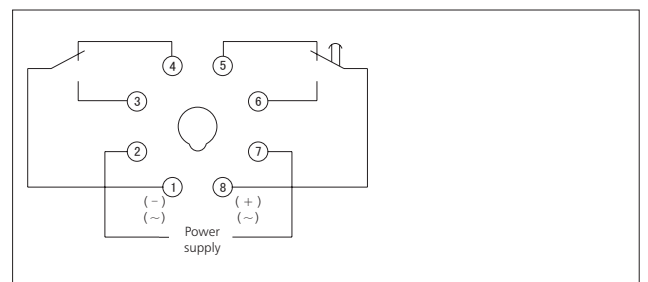

5. Overall and mounting dimensions (mm)

Profile and installation dimension

Opening size

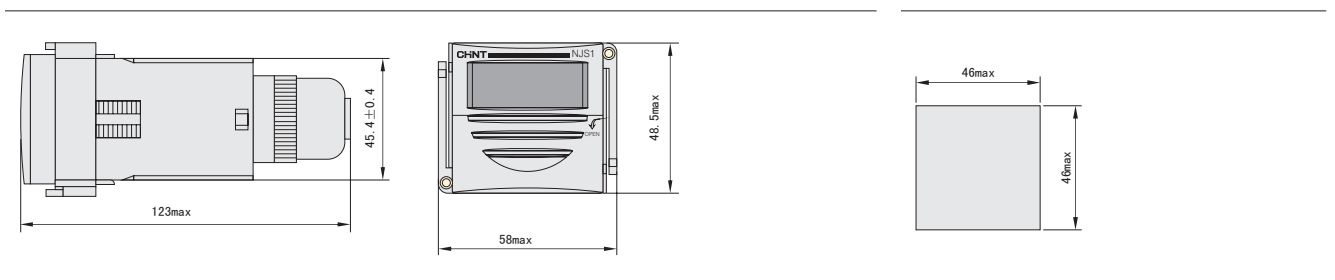



NTE8 Time Delay Relay

1. General

NTE8 Series time delay relay is applicable for controlling circuit @AC 50Hz/60Hz, up to 230V rated voltage or up to DC 24V rated voltage as delay element to make or break circuit according to preset time.

This product meets the requirements of IEC60947-5-1.

2. Type designation

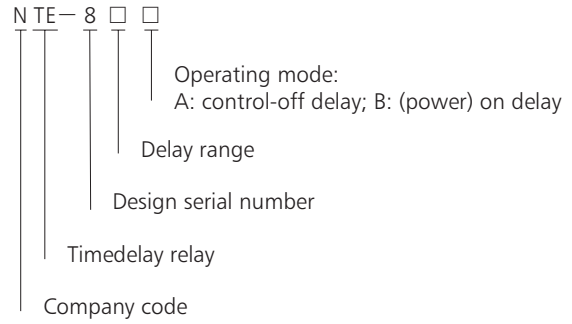

3. Technical data

Type	NTE8
Operating mode	Control-off delay/(power) on delay
Delay range	0.1s~10s, 10s~120s, 30s~480s
Number of contacts	Delay 1 N/O
Contact capacity	Ue/Ie:AC-15 230V/1A; DC-13 30V/1A; Ith:5A
Operational voltage	AC230V, AC24V, DC24V
Electrical life	1×10^5
Mechanical life	1×10^6
Ambient temperature	-5℃~+40℃
Mounting type	Rail type

Figure 2 NTE8-□A Relay wiring diagram

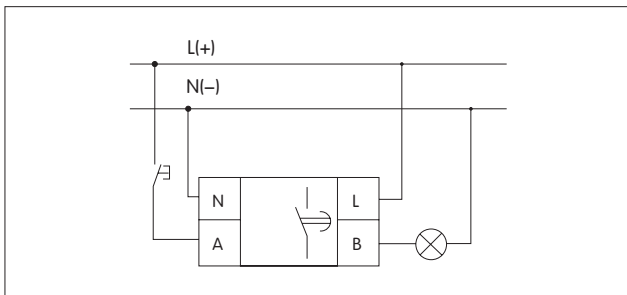
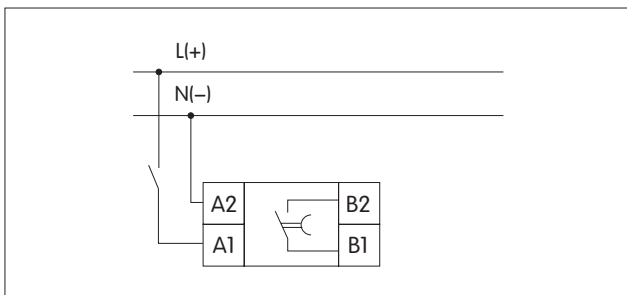
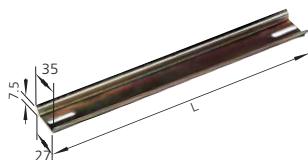
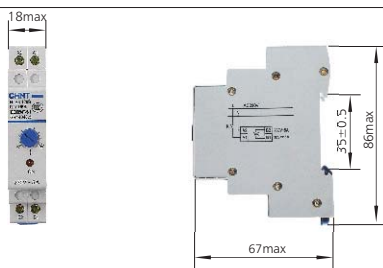

Figure 3 NTE8-□B Relay wiring diagram



4. Overall and mounting dimensions (mm)



Adopt TH35-7.5 sectional steel guide rail for installation

3. Technical data

3.1 Main specifications see Table

Type	JSS48A	JSS48A-2Z	JSS48A-11	JSS48A-G	JSS48A-P	JSS48A-S
Operating mode	Power on delay	Power on delay	Power on delay	Power on delay	Power on delay	Circulation-delay
Contact number	Delay 1 changerover	Delay 2 changerover	Delay 2 changerover	Delay 2 changerover	Delay 2 changerover	Delay 1 changerover
Contact capacity	Ue/Ie:AC-15 220V/0.75A,380V/0.47A; DC-13 220V/0.27A; Ith:5A					
Operating voltage	AC/DC: 24V~48V, 100V~240V, AC220V, AC380V, 50Hz/60Hz					
Electrical Endurance	1 × 10 ⁵					
Mechanical Endurance	1 × 10 ⁶					
Delay precision	≤ 1%					
Ambient temperature	-5℃ ~ +40℃					
Power consumption	≤ 3VA					
Installation mode	Panel type					

Type	Delay range
JSS48A	
JSS48A-11	1s~99min99s, 1min~99h99min, 0.01s~99.99s
JSS48A-2Z	
JSS48A-S	1s~99s, 1min~99min, 1h~99h
JSS48A-G2	
JSS48A-P2	0.1s~9.9s, 1s~99s, 0.1min~9.9min, 1min~99min
JSS48A-G3	0.01s~9.99s, 0.1s~99.9s, 1s~999s,
JSS48A-P3	0.1min~99.9min, 1min~999min
JSS48A-G4	0.01s~99.99s, 0.1s~999.9s, 1s~9999s, 0.1min~999.9min,
JSS48A-P4	1min~9999min, 0.1h~999.9h

4. Wiring diagram

JSS48A Wiring diagram

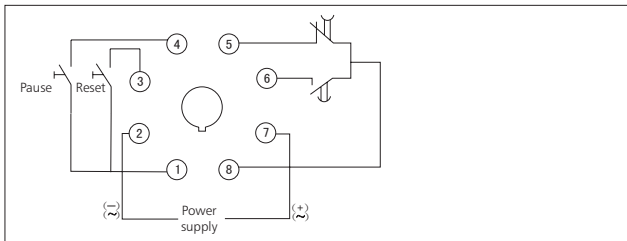

JSS48A-2Z, JSS48A-G, JSS48A-P Wiring diagram

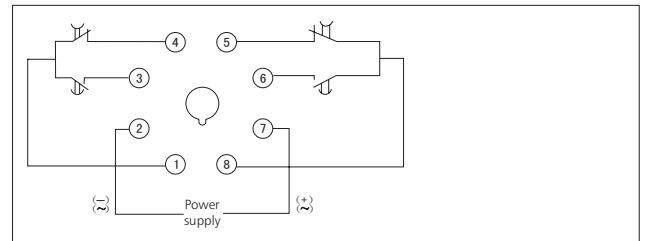

JSS48A-11 Wiring diagram

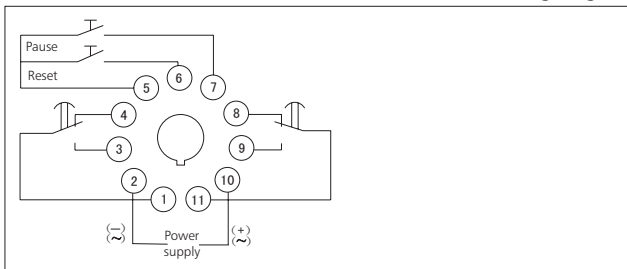

JSS48A-S Wiring diagram

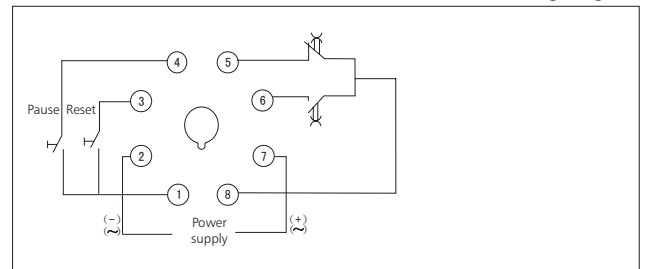

5. Overall and mounting dimensions (mm)

Profile and installation dimension

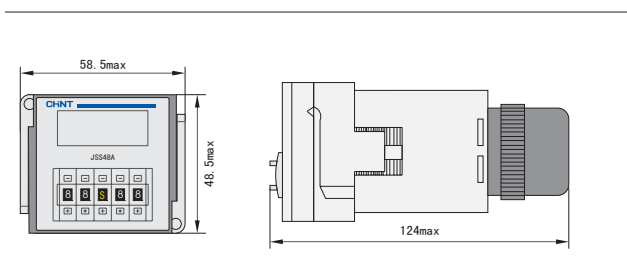

Opening size

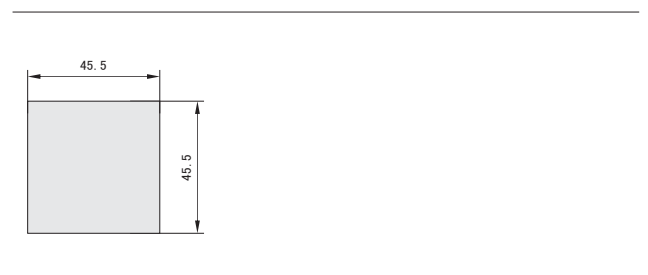



JSS48B Time Delay Relay

1. General

JSS48B Time Delay Relay is applicable for controlling circuit @ A.C. 50Hz/60Hz, up to 380V rated supply voltage and up to D.C. 240V rated supply voltage as delay element to make or break circuit according to preset time.

2. Type designation

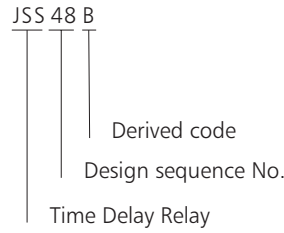

Note: this product is applicable for wide range operating voltage, for instance, operating voltage within AC/DC24V~48V means it can operate normally within the voltage range of AC/DC 24V to 48V.

3. Technical data

Type	JSS48B
Operating mode	Power on delay
Contact number	Delay 1 Switching
Operating voltage	AC/DC: 24V~48V, 100V~240V, AC220V AC380V 50Hz/60Hz
Electrical Endurance	1×10^5
Mechanical Endurance	1×10^6
Delay precision	$\pm 0.05\% \pm 50\text{ms}$
Ambient temperature	$-5^{\circ}\text{C} \sim +40^{\circ}\text{C}$
Delay range	0.01s~99.99s 1s~99min59s 1min~99h59min
Installation mode	Panel type

4. Wiring diagram

JSS48B Wiring diagram

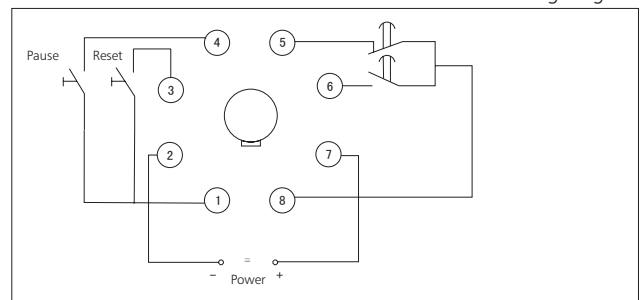

5. Overall and mounting dimensions (mm)

Profile and installation dimension of JSS48B series products

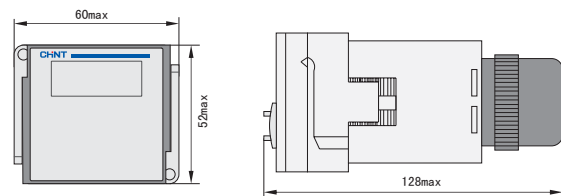

Opening size

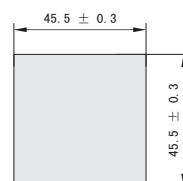



JSZ3 Time Delay Relay

1. General

JSZ3 Time Delay Relay is applicable for automatic control system, such as machine automatic control, and complete equipment automatic control, etc.

2. Type designation

JS Z 3 □ - □

Adopt A, B, C, D, E, F, G to represent delay range code (applicable for multi-range type)

A: basic type power on delay, multi-range type)

B: multi-function (multi-delay mode, with starting control), multi-range type

C: instantaneously operation type power on delay, multi-range type

F: turn-off power off delay type

H: instantaneously operation type power on delay, single-range type

Y: delta start-delay type power on delay

K: control off-delay

R: repeat circulation-delay type power on delay

-2, 3: power on delay, single-range type

Design sequence No.

Integrative type

Time Delay Relay

3. Technical data

Type	JSZ3A	JSZ3C	JSZ3F	JSZ3K	JSZ3Y	JSZ3R
Operating mode	power on delay	JSZ3C power on delay with instantaneously operation contact	power off delay	Signal breaking-delay	Delta start-delay	Reciprocating circulation-delay
Delay range	A: 0.05-0.5s/5s/30s/3min		0.1-1s	0.1-1s		
	B: 0.1-1s/10s/60s/6min		0.5-5s	0.5-5s	0.1-1s	0.5-6s/60s
	C: 0.5-5s/50s/5min/30min		1-10s	1-10s	0.5-5s	1-10s/10min
	D: 1-10s/100s/10min/60min		2.5-30s	2.5-30s	1-10s	2.5-30s/30min
	E: 5-60s/10min/60min/6h		5-60s	5-60s	2.5-30s	5-60s/60min
	F: 0.25-2min/2min/2h/12h		10-180s	10-180s	5-60s	
	G: 0.5-4min/40min/4h/24h					
Set mode	Potentiometer					
Operating voltage	AC50Hz/60Hz, 36V, 110V, 127V, AC220V AC230V AC380V AC400V DC24V		AC50Hz/60Hz, 36V, 110V, 127V AC220V AC230V AC380V AC400V DC24V	AC50Hz/60Hz AC110V AC220V AC230V AC380V AC400V DC24V	AC110V/220V 50Hz/60Hz AC220V AC230V AC380V AC400V DC24V	AC110V/220V 50Hz/60Hz AC220V AC230V AC380V AC400V DC24V
Delay precision	≤10%		≤10%	≤10%	≤10%	≤10%
Contact number	Delay 2 switching, delay 1 changeover, instantaneous switching		Delay 1 switching or delay 2 switching	Delay 1 switching	Delay Delta 1 switching	Delay 1 switching
Contact capacity	Ue/Ie: AC-15 220V/0.75A, 380V/0.47A; DC-13 220V/0.27A;Ith:5A					
Electrical Endurance	1 × 10 ⁵					
Mechanical Endurance	1 × 10 ⁶					
Ambient temperature	-5℃ ~ +40℃					
Installation mode	Panel type, Equipment type					
Matched pedestal	Panel type: FM8858, FM8858X, Equipment type, CZS08X, CZS08X-E					

Continued

Type	JSZS-2	JSZ3-3
Operating mode	power on delay	
Delay range	0.1-1s, 0.5-5s, 1-10s 3-30s, 6-60s, 0.3-3min, 0.5-5min, 1-10min, 1.5-15min, 3-30min 0.1-1h	
Set mode	Potentiometer	
Operating voltage	AC50Hz/60Hz 36V, 110V, 127V, 220V, 230V, 380V, 400V DC24V(other voltage could be custom made)	
Delay precision	≤10%	
Contact number	Delay 2 switching	Delay 1 switching, instantaneously operation 1 switching
Contact capacity	Ue/Ie: AC-15 220V/0.75A, 380V/0.47A; DC-13 220V/0.27A;Ith:5A	
Electrical Endurance	1 × 10 ⁵	
Mechanical Endurance	1 × 10 ⁶	
Ambient temperature	-5℃ ~ +40℃	
Installation mode	Panel type, Equipment type, Track type	
Matched pedestal	Panel type: FM8858, FM8858X; Equipment type: CZS08X	

4. Wiring diagram

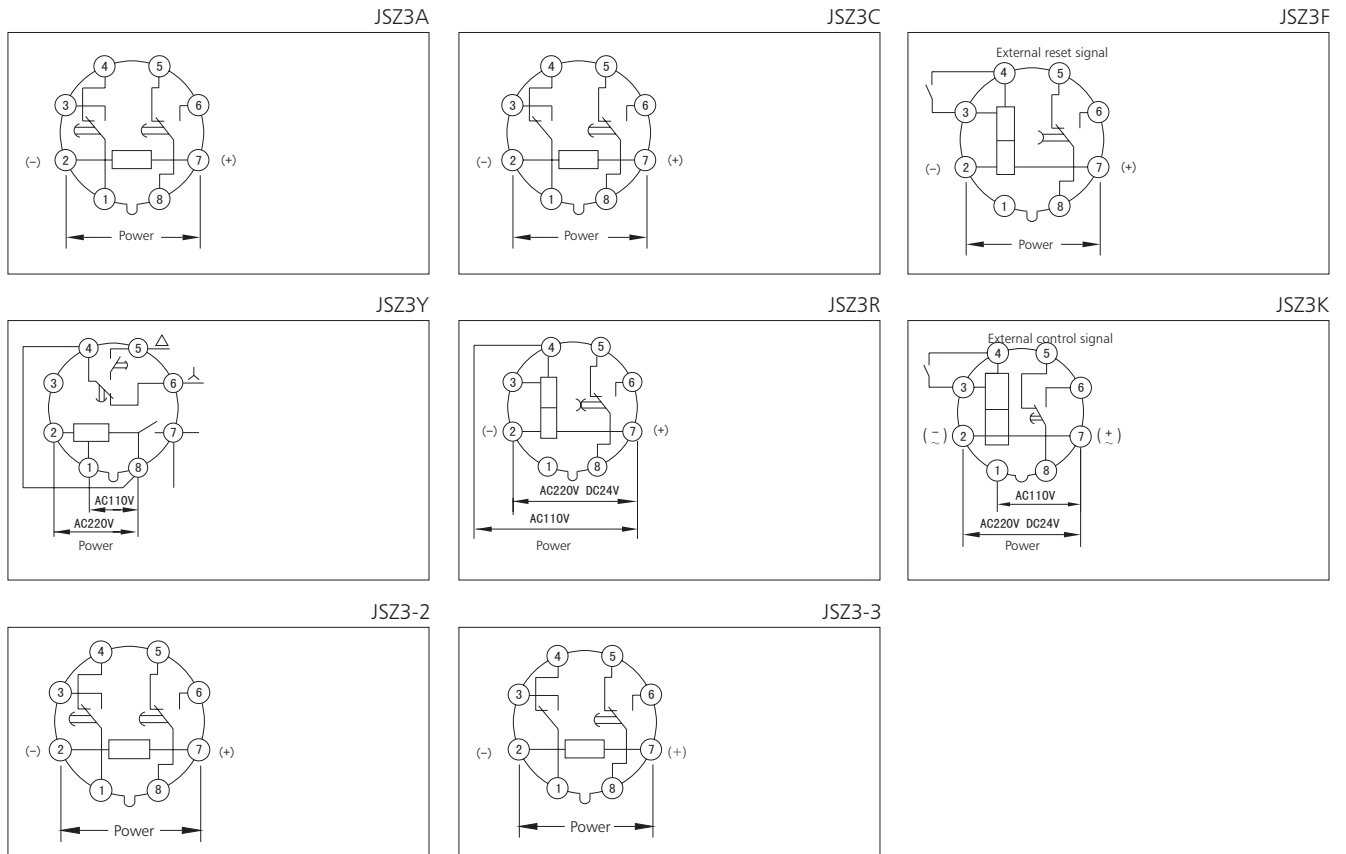

5. Overall and mounting dimensions (mm)

JSZ3A-C, F, K, Y Profile and installation dimension

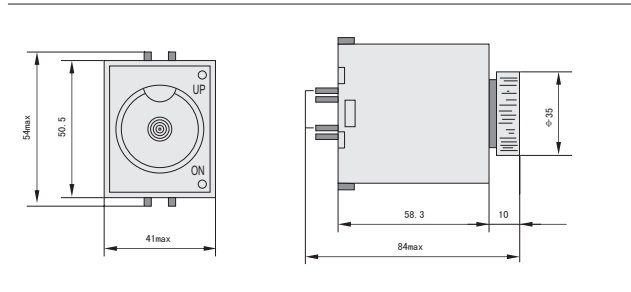

JSZ3R Profile and installation dimension

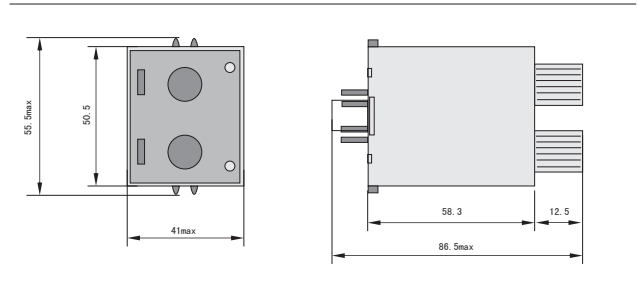

JSZ3-2, 3, Profile and installation dimension

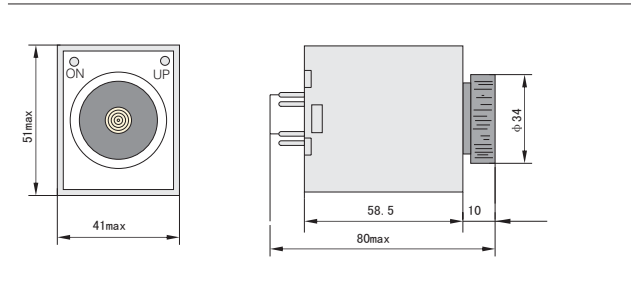

Opening size

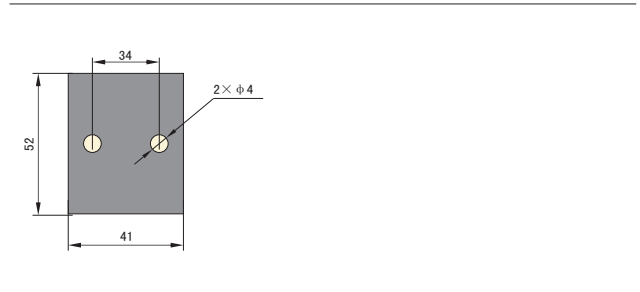



JSZ4 Time Relay

1. Type designation

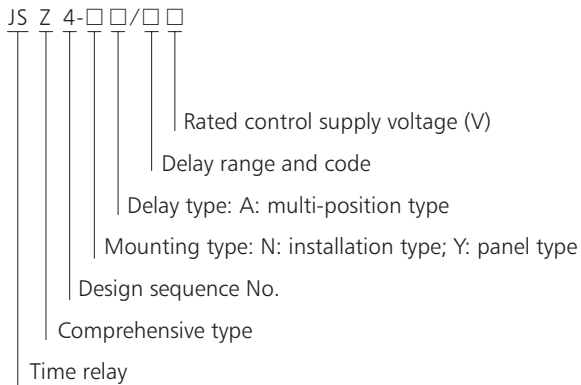

2. Technical data

Model	JSZ4-YA	JSZ4-NA
Operating mode	On-delay or on-delay with instantaneous acting	
Number of contacts	Delay 2 change-over or delay 1 change-over, instantaneous 1 change-over (optional by switch)	
Contact capacity	Ue/Ie: AC-15 220V/0.75A, 380V/0.47A; DC-13 220V/0.27A; Ith:5A	
Delay range	A: 1s/10s/1min/10min B: 3s/30s/3min/30min C: 6s/60s/6min/60min D: 1min/10min/1h/10h E: 3min/30min/3h/30h F: 6min/60min/6h/60h	
Operational voltage	AC50Hz 36V, 110V, 220V, 380V DC24V (Other voltages available upon request)	
Electrical life	1 × 10 ⁵	
Mechanical life	1 × 10 ⁶	
Delay accuracy	≤ 10%	
Ambient temperature	-5°C~+40°C	
Mounting type	Panel type	Installation type

3. Wiring diagram

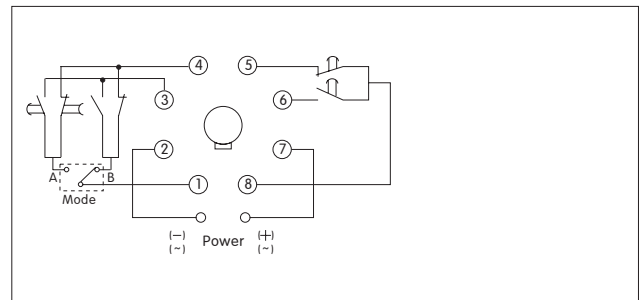

4. Overall and mounting dimensions (mm) JSZ4-NA

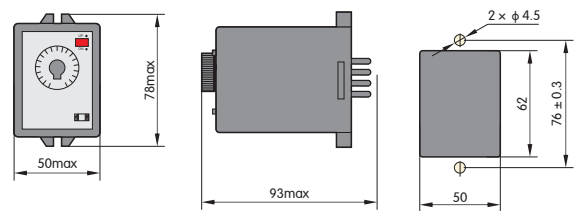

JSZ4-YA

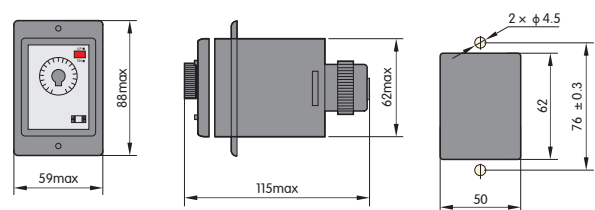



JSZ6 Time Delay Relay

1. General

JSZ6 Time Delay Relay is applicable for automatic control system, such as machine tool automatic control, complete equipment automatic control. Etc.

2. Type designation

JS Z 6 - □



2: Delay 2 changeover; 4: Delay 4 changeover

Design sequence No.

Integrated type

Time delay Relay

3. Technical data

Type	JSZ6-2	JSZ6-4
Operating mode	power on delay	power on delay
Contact number	Delay 2 changeover	Delay 4 changeover
Contact capacity	Ue/Ie: AC-15 220V/0.75A, 380V/0.47A; DC-13 220V/0.27A; Ith:5A	
Delay range	0.1-1s, 5-5s, 1-10s, 2.5-30s, 5-60s, 15-180s, 1-10min, 2.5-30min, 5-60min,	
Operating voltage	AC50Hz/60Hz 36V, 110V, 127V, AC220V, DC24V	
Electrical life	1 × 10 ⁵	
Mechanical life	1 × 10 ⁶	
Set mode	Potentiometer	
Repeat precision	≤ 10%	
Ambient temperature	-5°C ~ +40°C	
Interchangeability	Can interchange with H3Y series for use	

4. Wiring diagram

JSZ6-2

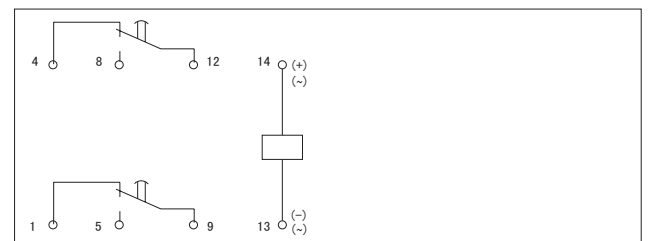

JSZ6-4

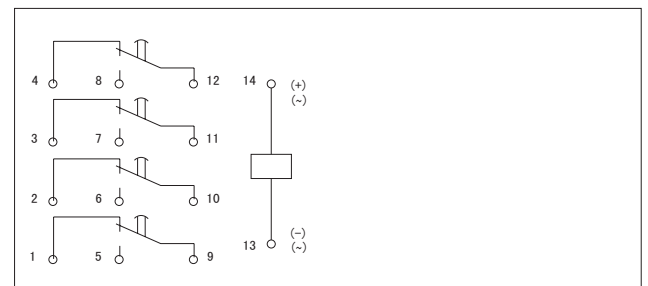

5. Overall and mounting dimensions (mm)

JSZ6 Profile and installation dimension

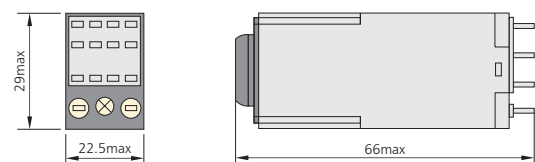

Opening size

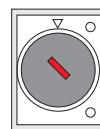



NJJ1 Counting Relay

1. General

NJJ1 Counting Relay is applicable for controlling circuit @ A.C. 50Hz/60Hz, 240V rated voltage of control power supply and D.C. 240V rated voltage of control power supply as counting or counting control element.

2. Type designation

N JJ 1 - □

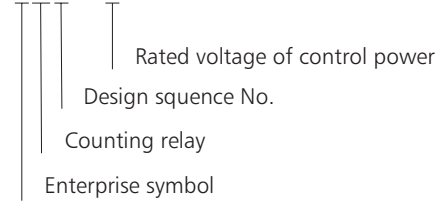

Note: this product is applicable for wide range of operating voltage, for instance, operating voltage within AC/DC100V~240V means it can operate normally within the voltage range of AC/DC 100V to 240V.

3. Technical data

Operating mode	85%~110% of rated voltage AC50Hz/60Hz AC/DC100V-240V, DC24V
Electrical life	1×10^5
Mechanical life	1×10^6
Output mode	1group changeover contact, open-collector output (30VDC 100mA Max)
Contact capacity	Ue/Ie:AC-15 220V/0.75A; DC-13 220V/0.27A; Ith:5A
Number of counting digits	At CR mode: 4-digit counting relay (4-digit red LED is count value, 4 digit green LED is preset value) At CT mode: 8 digit reversible summation counter (green LED is low 4-digit, red is high 4-digit)
Counting speed	1 time/s, 30 times/s, 1000times/s are provided for selection
Counting mode	Plus, minus, plus minus inverse A, plus minus inverse B, plus minus inverse C
Input signal	Contact input, sensor input (NPN type/ PNP type are provided for selection)
Magnitude setting	With magnitude setting, range 0.01~9.99
Output mode	N, F, C, R, K, P, Q, A
Output time	Settable output time 0.01s~9.99s (when output mode is C, R, K, P, Q, A)
Ambient temperature	-5°C ~ +40°C
Power consumption	≤3W
Installation mode	Panel type
External dimension	W58×H48×L197 mm
Current failure memory	>10 years

4. Wiring diagram

Count wiring diagram

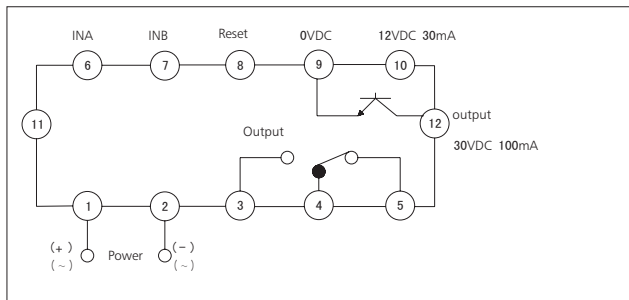

5. Overall and mounting dimensions (mm)

External dimension

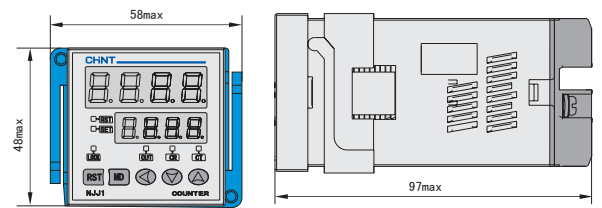

Opening size

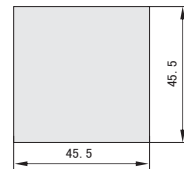

6. Sequence diagram of counting mode

Counting mode	Timing-sequence diagram	Remark
□ Addition counting mode		Count at INA rising edge, stop counting at INB input.
		Count at INB input falling edge at INA input.

Counting mode	Timing-sequence diagram	Remark
d Subtraction counting mode		Count at INA rising edge, stop counting at INB input.
		Count at INB input falling edge at INA input.
Ud-R Reversible counting mode A		Reversible counting mode A: Addition counting at INA input, subtraction counting when INB input is active.
Ud-b Reversible counting mode B		Reversible counting mode B: Addition counting at INA input, subtraction counting at INB input.
Ud-C Reversible counting mode C		Reversible counting mode C: Automatic recognition of positive and reverse rotations, addition and subtraction counting.

7. Sequence diagram of output mode

Output mode	Plus counting mode	Minus counting mode	Inverse counting mode A, B, C
N			
F(F)			

Output mode	Plus counting mode	Minus counting mode	Inverse counting mode A, B, C
ξ (C)			
Γ (R)			
ξ (K)			
ρ (P)			
η (Q)			
β (A)			

Note: t is the output time, which can be set by the user.



NJJ3 Counting Relay

1. General

NJJ3 Counting Relay is applicable for controlling circuit @ A.C. 50Hz/60Hz, 240V rated voltage of control power supply and D.C. 240V rated voltage of control power supply as counting or counting control element.

2. Type designation

N JJ 3 / □

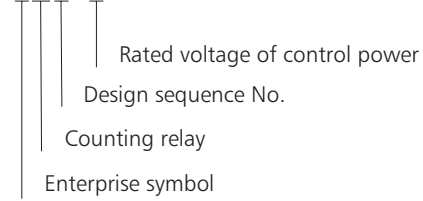

Note: this product is applicable for wide range of operating voltage, for instance, operating voltage within AC/DC100V~240V means it can operate normally within the voltage range of AC/DC 100V to 240V.

3. Technical data

Operating mode	85%-110% of rated voltage AC50Hz/60Hz AC/DC100V-240V, DC24V
Electrical life	1×10^5
Mechanical life	1×10^6
Output mode	1group changeover contact, open-collector output (30VDC 100mA Max), batch process output
Contact capacity	U _e /I _e : AC-15 220V/0.75A, 380V/0.47A; DC-13 220V/0.27A; I _{th} :5A
Number of counting digits	6-digit counting relay (6-digit red LED is count value, 6-digit green LED is preset value)
Counting speed	1 time/s, 30 times/s, 1000times/s are provided for selection
Counting mode	Plus, minus, plus minus inverse A, plus minus inverse B, plus minus inverse C
Batch process	Settable range 0–999999
Input signal	Contact input, sensor input (NPN type/ PNP type are provided for selection)
Magnitude setting	With magnitude setting, range 0.001–99.999
Output mode	N, F, C, R, K, P, Q, A
Output time	Settable output time 0.01s–9.99s (when output mode is C, R, K, P, Q, A)
Ambient temperature	-5°C ~ +40°C
Power consumption	3W
Installation mode	Panel type
External dimension	W88×H72×L97 mm
Current failure memory	> 10 years

4. Wiring diagram

Count wiring diagram

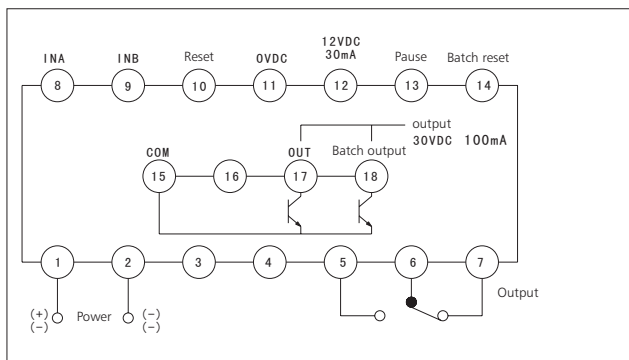

5. Overall and mounting dimensions (mm)

External dimension

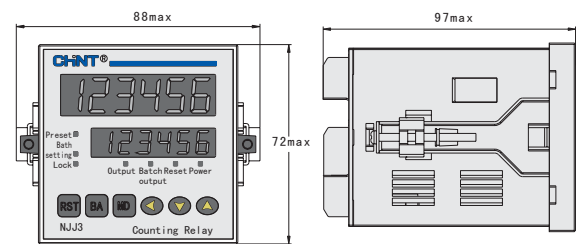

Opening size

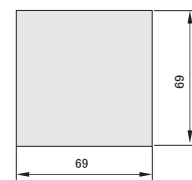

6. Sequence diagram of counting mode

Counting mode	Timing-sequence diagram	Remark
		Count at INA rising edge, stop counting at INB input.
⊥ Addition counting mode		Count at INB input falling edge at INA input.

Counting mode	Timing-sequence diagram	Remark
d Subtraction counting mode	<p>*n Preset value</p>	Count at INA rising edge, stop counting at INB input.
	<p>*n Preset value</p>	Count at INB input falling edge at INA input.
Ud-F Reversible counting mode A		Reversible counting mode A: Addition counting at INA input, subtraction counting when INB input is active.
Ud-b Reversible counting mode B		Reversible counting mode B: Addition counting at INA input, subtraction counting at INB input.
Ud-C Reversible counting mode C		Reversible counting mode C: Automatic recognition of positive and reverse rotations, addition and subtraction counting.

7. Sequence diagram of output mode

Output mode	Plus counting mode	Minus counting mode	Inverse counting mode A, B, C
N			
F(F)			

Output mode	Plus counting mode	Minus counting mode	Inverse counting mode A, B, C
ξ (C)			
Γ (R)			
ξ (K)			
ρ (P)			
φ (Q)			
β (A)			

Note: t is the output time, which can be set by the user.



NJJ5-J Electronic Counter

1. General

This product adopts microminiature design and is applicable for counting in various circuits.

2. Type designation

NJJ5-J □ □ / □

- Rated operational voltage
- Nil: normal type; E: with extended panel type
- L: low speed type 10 times/s
- H: high speed type 1000 times/s
- J: counter L: time accumulator
- Product series model

Note: this product is applicable for wide range operating voltage, for instance, operating voltage within AC/DC100V~240V means it can operate normally within the voltage range of AC/DC 100V to 240V.

3. Technical data

Operating voltage	85%-110% of rated voltage AC50Hz/60Hz AC/DC100V-240V, DC24V
Counting range	0~999999
Counting speed	10 times/s or 1000 times/s
Input signal	Contact input, relay input (NPN type)
Reset mode	Panel button reset, external terminal reset
Reset min pulse width	20ms
Counting error	±1 time
Current failure memory	> 10 years
Power consumption	About 1.5VA
Installation mode	Panel type
Ambient temperature	-5°C~+40°C

4. Wiring diagram

NJJ5-J contact signal input

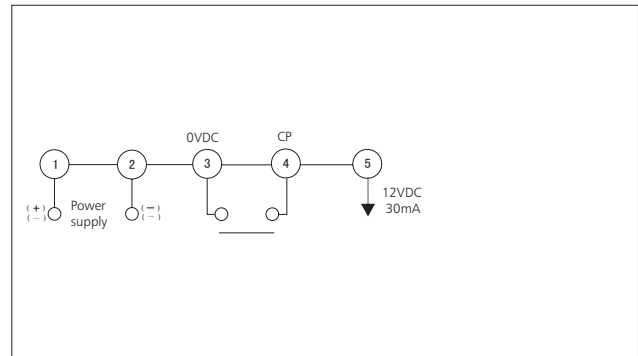

NJJ5-J sensor signal input

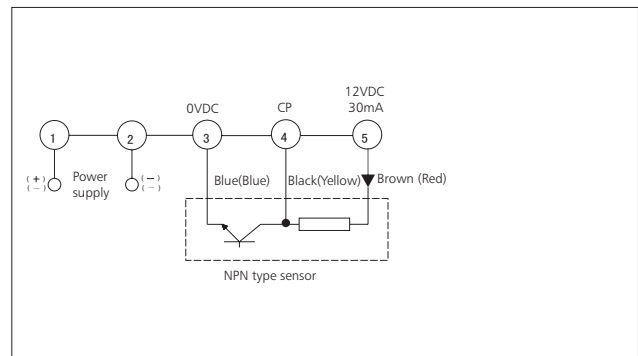

5. Overall dimensions

Profile and installation dimension

Opening size

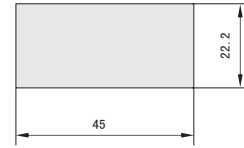
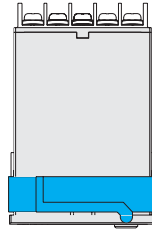
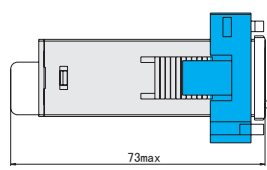
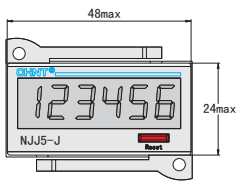

6. Extended panel type

Profile and installation dimension of extended panel type

Opening size of extended panel type

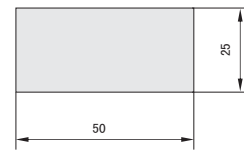
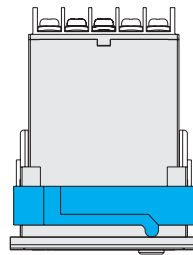
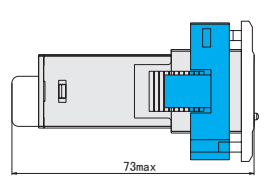
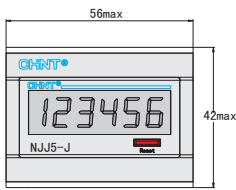

7. Operating timing-sequence diagram

NJJ5-J operating timing-sequence diagram

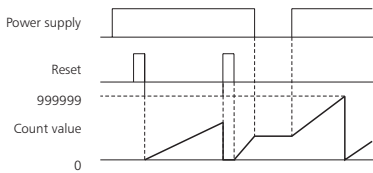



NJJ5-L Electronic Time Accumulator

1. General

This product adopts microminiature design and is applicable for accumulating time in various circuits.

2. Type designation

NJJ5-L □ □ / □

Rated operational voltage

Nil: normal type; E: with extended panel type

1: 99999.9h

2: 99h59min59s

3: 9999h59min

4: 9999day23h

J: counter L: time accumulator

Product series model

Note: This product is applicable for wide range operating voltage, for instance, operating voltage within AC/DC100V~240V means it can operate normally within the voltage range of AC/DC 100V to 240V.

3. Technical data

Operating voltage	85%-110% of rated voltage AC50Hz/60Hz AC/DC100V-240V, DC24V
Accumulating time range	99999.9h, 99h59min59s, 9999h59min, 9999day23h
Resetting mode	Panel button resetting, external terminal resetting
Resetting min pulse width	20ms
Accumulative error	≤0.02%
Current failure memory	> 10 years
Power consumption	1.5VA approx.
Installation mode	Panel type
Ambient temperature	-5°C ~+40°C

4. Wiring diagram

NJJ5-L contact signal input

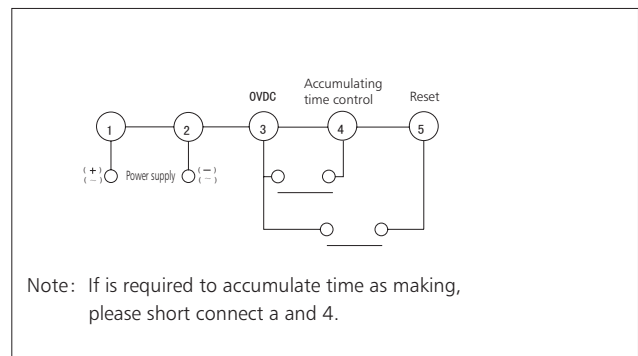

NJJ5-L sensor signal input

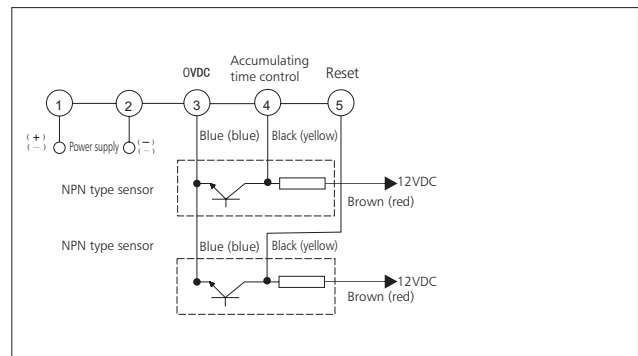

5. Overall and mounting dimensions (mm)

Profile and installation dimension

Opening size

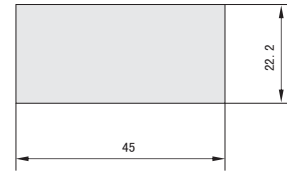
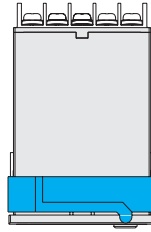
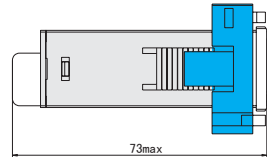
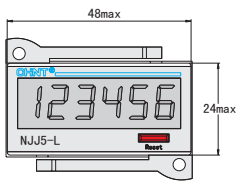

6. Extended panel type

Profile and installation dimension of extended panel type

Opening size of extended panel type

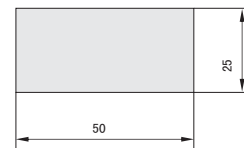
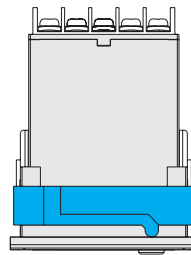
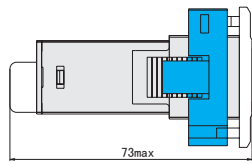
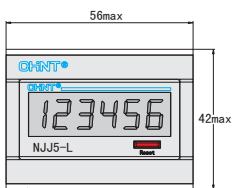

7. Operating timing-sequence diagram

NJJ5-L operating timing-sequence diagram

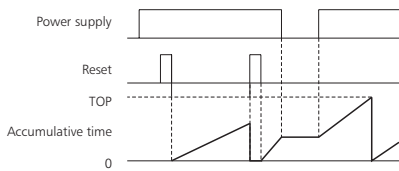



NJJ6 Counting Relay

1. General

NJJ6 counting relay is used to provide counting and counting control in control circuits with an AC frequency of 50Hz and a rated control voltage of up to 240V and control circuits with a DC rated control supply voltage of up to 240V.

2. Type designation

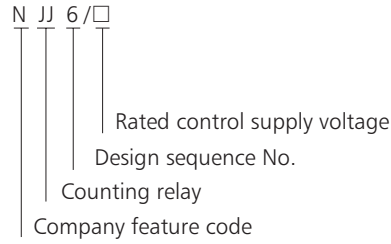

Note: Some models of this product apply to a wide range of operational voltage. For example, an operational voltage of AC/DC100V~240V means that it can operate normally within the voltage range of AC or DC 100V to 240V.

3. Technical data

Operational voltage	85%-110% of rated voltage AC50Hz AC/DC100V-240V, DC24V
Electrical life	1×10 ⁵
Mechanical life	1×10 ⁶
Output mode	1 group of change-over contacts
Contact capacity	Ue/Ie: AC-15 220V/0.75A, 380V/0.47A; DC-13 220V/0.27A; Ith:0.5A
Counting digits	6-digit counting relay (the upper 6-digit LCD is the count value, the lower 6-digit LCD is the preset value)
Counting rate	1 time/second, 30 times/second, 1000 times/second (can be set)
Counting mode	Addition, subtraction, reversible A, reversible B, reversible C
Input signal	Contact input, sensor input (NPN type/PNP type can be set)
Value setting	Can be set within the range 0.001~99.999
Output mode	N, F, C, R, K, P, Q, A
Output time	The output time can be set within 0.01s~9.99s (under output mode C, R, K, P, Q or A)
Ambient temperature	-5℃~+40℃
Power consumption	3VA
Mounting type	Panel type
Overall dimensions	W58×H48×L97mm
Opening size	W45.5×H45.5mm
Power-off memory	More than 10 years (can be set)

4. Wiring diagram

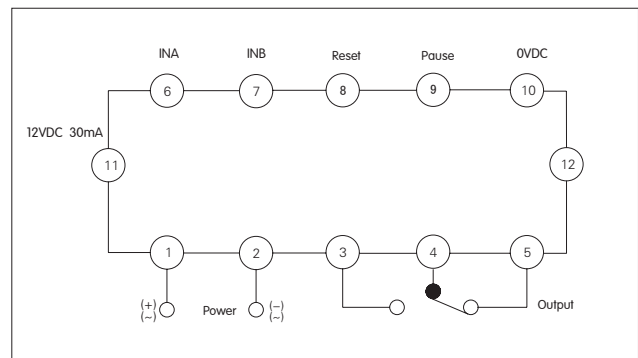

5. Overall and mounting dimensions (mm)

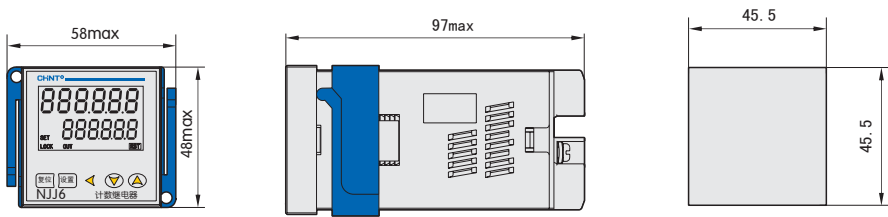

6. Sequence diagram of counting mode

Counting mode	Timing-sequence diagram	Remark
↳ Addition counting mode		Count at INA rising edge, stop counting at INB input.
↳ Subtraction counting mode	<p>*n Preset value</p>	Count at INA rising edge, stop counting at INB input.
↳ Reversible counting mode A		Reversible counting mode A: Addition counting at INA input, subtraction counting when INB input is active.

Counting mode	Timing-sequence diagram	Remark
\sqcup -b Reversible counting mode B		Reversible counting mode B: Addition counting at INA input, subtraction counting at INB input.
\sqcup -c Reversible counting mode C		Reversible counting mode C: Automatic recognition of positive and reverse rotations, addition and subtraction counting.

7. Sequence diagram of output mode

Output mode	\sqcup Plus counting mode	\sqcap Minus counting mode	Inverse counting mode A, B, C
\sqcap (N)			
F (F)			
\sqcup (C)			
\sqcap (R)			

Output mode	Plus counting mode	Minus counting mode	Inverse counting mode A, B, C
K			
P			
Q			
A			

Note: t is the output time, which can be set by the user.



JDM15G Counting Relay

1. General

JDM15G counting relay is used as a counting or counting control element in control circuits with an AC frequency of 50Hz and a rated control supply voltage of up to 240V and control circuits with a DC rated control supply voltage of up to 240V.

2. Type designation

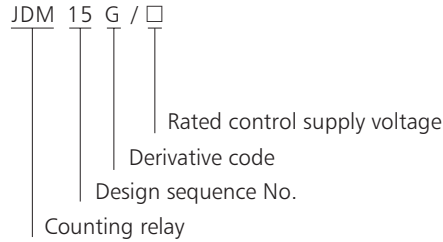

Note: Some models of this product apply to a wide range of operational voltage. For example, an operational voltage of AC/DC100V~!240V means that it can operate normally within the voltage range of AC or DC 100V to 240V.

3. Technical data

Operational voltage	85%-110% of rated voltage AC50Hz AC/DC100V-240V
Electrical life	1×10 ⁵
Mechanical life	1×10 ⁶
Output mode	2 groups of change-over contacts, open collector output (30VDC 100mA max)
Contact capacity	Ue/Ie: AC-15 220V/0.75A, 380V/0.47A; DC-13 220V/0.27A; Ith:0.5A
Counting digits	6-digit counting relay
Counting rate	30 times/second, 1000 times/second, can be set by the user
Counting mode	Addition, addition×10, addition×100, subtraction, reversible A, reversible B, reversible C
Input signal	Contact input, sensor input (NPN type/PNP type can be set)
Output mode	N, F, C, R
Output time	The output time can be set within 0.01s~9.99s (under output mode C or R)
Ambient temperature	-5℃~+40℃
Power consumption	≤3VA
Mounting type	Panel type
Overall dimensions	W88×H76×L104mm
Opening size	W69×H69mm
Power-off memory	More than 10 years (can be set)

4. Wiring diagram

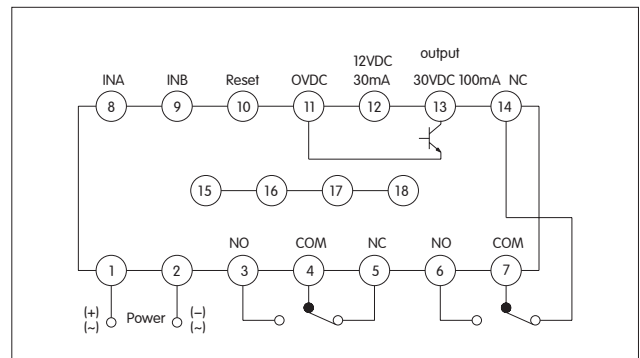

5. Overall and mounting dimensions (mm)

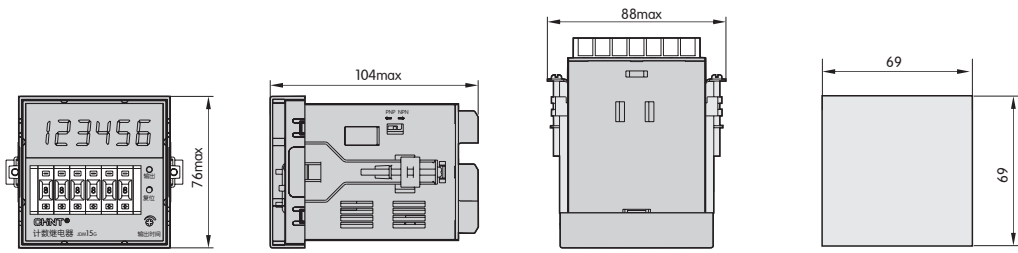

6. Sequence diagram of counting mode

Counting mode	Timing-sequence diagram	Remark
<p>U Addition counting mode</p>		Count at INA rising edge, stop counting at INB input.
<p>d Subtraction counting mode</p>	<p>*n Preset value</p>	Count at INA rising edge, stop counting at INB input.
<p>Ud-R Reversible counting mode A</p>		Reversible counting mode A: Addition counting at INA input, subtraction counting when INB input is active.

Counting mode	Timing-sequence diagram	Remark
<p>⏏-b Reversible counting mode B</p>		<p>Reversible counting mode B: Addition counting at INA input, subtraction counting at INB input.</p>
<p>⏏-c Reversible counting mode C</p>		<p>Reversible counting mode C: Automatic recognition of positive and reverse rotations, addition and subtraction counting.</p>

7. Sequence diagram of output mode

Output mode	⏏ Plus counting mode	⏏ Minus counting mode	Inverse counting mode A, B, C
⏏ (N)			
F (F)			
⏏ (C)			
⏏ (R)			

Note: t is the output time, which can be set by the user.



JDM1-48 Counting Relay

1. General

JDM1 series counting relay is used as a counting or counting control element in control circuits with an AC frequency of 50Hz and a rated control supply voltage of up to 380V and control circuits with a DC rated control supply voltage of up to 240V.

2. Type designation

JDM 1 - 48 □ □ □ / □

Rated control supply voltage
(AC/DC24V~48V, AC/DC100V~240V,
AC220V, AC380V)

Blank: without power-off memory,
M: with power-off memory

Number of terminals: 8: 8 pins,
11: 11 pins (with 12V output for the sensor)

Counting rate:

L: low speed type, 30 times/second

H: high speed type, 200 times/second

Feature code: 6, 9, 14, 48

Design sequence No.

Counting relay

Note: Some models of this product apply to a wide range of operational voltage. For example, an operational voltage of AC/DC24V~48V means that it can operate normally within the voltage range of AC or DC 24V to 48V.

3. Technical data

Operational voltage	85%-110% of rated voltage AC50Hz AC/DC100V-240V
Electrical life	1×10^5
Mechanical life	1×10^6
Output mode	1 group of change-over contacts
Contact capacity	Ue/Ie: AC-15 220V/0.75A, 380V/0.47A; DC-13 220V/0.27A; Ith:3A
Counting digits	4-digit counting relay
Counting rate	30 times/second or 200 times/second
Counting mode	Addition, addition $\times 10$, addition $\times 100$ (subtraction counting available upon request)
Input signal	Contact input, NPN type sensor input (PNP type available upon request)
Output mode	N
Ambient temperature	-5°C~+40°C
Power consumption	$\leq 3VA$
Mounting type	Panel type (with socket for rail mounting)
Overall dimensions	W58×H52×L128mm
Opening size	W45.5×H45.5mm
Power-off memory	More than 10 years (power-off memory type)

4. Wiring diagram

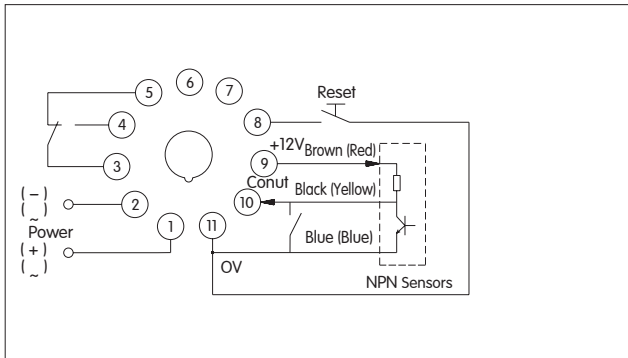
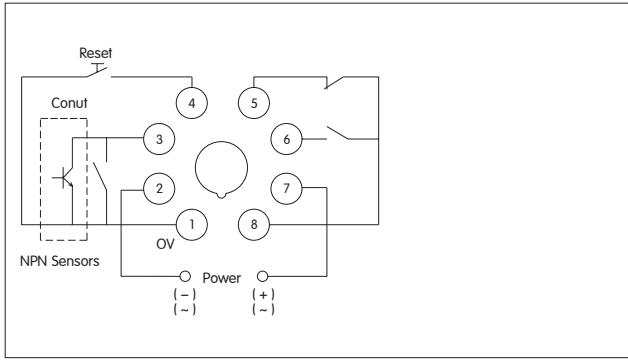

5. Overall and mounting dimensions (mm)

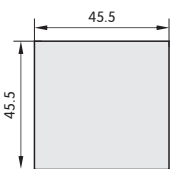
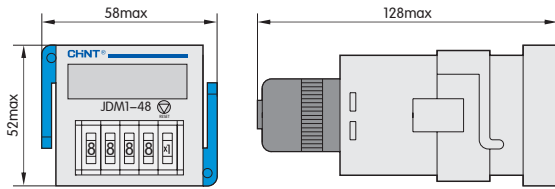

6. Sequence diagram of counting mode

JDM1-48 Timing Chart (No blackout memory)

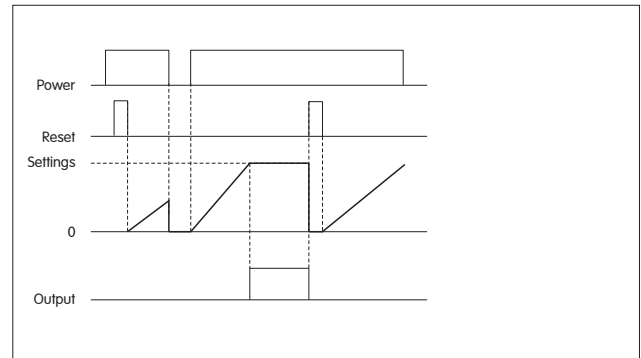

JDM1-48 Timing Chart (With power and memory)

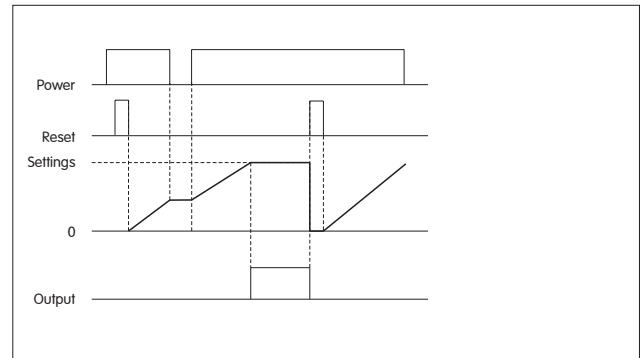



JDM3 Microminiature Electronic Counter

1. General

JDM3 microminiature electronic counter has built-in lithium battery and small overall dimensions and is used to provide counting in various types of circuits.

2. Type designation

JDM 3 - □ □ □

L : low speed counting, 10 times/second;
H: high speed counting, 200 times/second.

Blank: without voltage input;
V: DC voltage input;
A: AC voltage input.

Counting digits: 6: 6-digit counting;
8: 8-digit counting.

Design sequence No.

Counter

3. Technical data

Power supply	Internal power supply
Battery life	Approximately 6 years (25°C)
Display mode	LCD display, zero elimination type (zero display type available upon request)
Output mode	Without output
Counting digits	6-digit counter or 8-digit counter
Counting rate	10 times/second or 200 times/second
Counting mode	Addition counting
Without voltage input	Maximum contact on resistance: ≤10kΩ (counting ON) Minimum contact off resistance: ≥500kΩ (counting OFF) Maximum input residual voltage: 0.5V
DC voltage input	L : DC0V-2V H : 4V-30V (H active) (input impedance: ≥4.7kΩ)
AC voltage input	AC/DC 24V~240V
Reset mode	Panel push-button reset (6-digit), external terminal reset (6-digit, 8-digit)
Minimum reset pulse width	≥0.2s
Counting error	≤±1 time
Ambient temperature	-5°C~+40°C
Mounting type	Panel type
Overall dimensions	W48×H24×L52.9mm
Opening size	W45×H22.5mm

4. Wiring diagram

JDM3 (without voltage input)

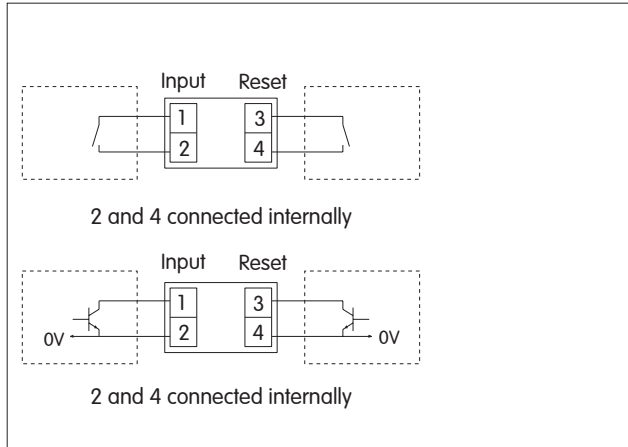

JDM3 (DC voltage input)

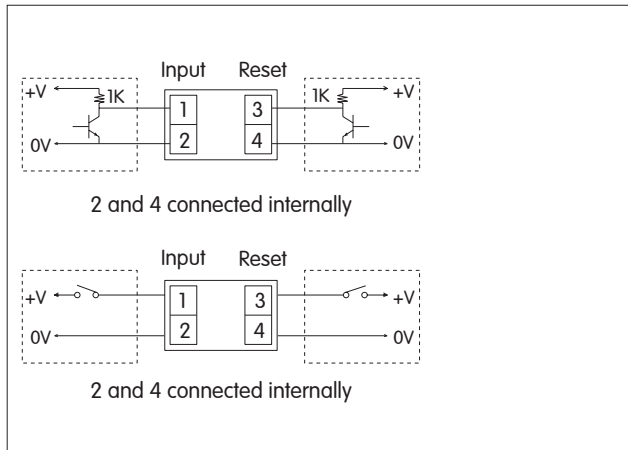

JDM3 (AC voltage input)

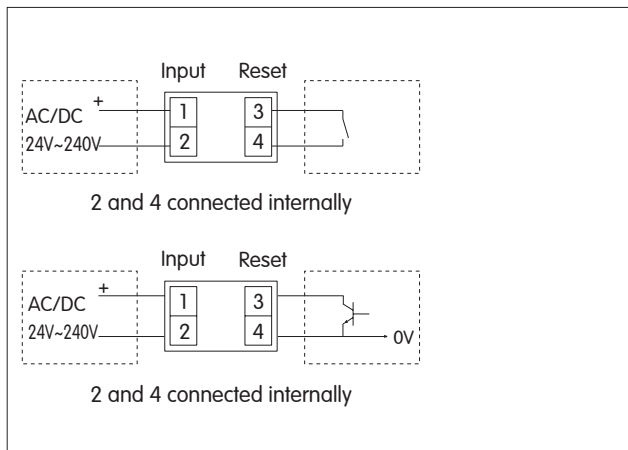

5. Overall and mounting dimensions (mm)

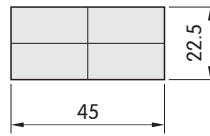
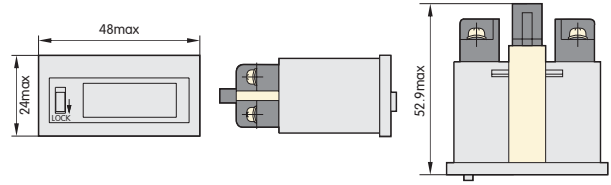



SC3L Microminiature Electronic Time Accumulator

1. General

SC3L microminiature electronic time accumulator has built-in lithium battery and small overall dimensions and is used to provide time accumulation in various types of circuits.

2. Type designation

S C 3 L - □ □

Input signal: Blank: without voltage input;
V: DC voltage input;
A: AC voltage input

Time accumulation range :

1: 99999.9h; 2: 99h59min59s;
3: 9999h59min; 4: 9999day23h;
5: 9999h59min59s; 6: 999999h59min59s;

Time accumulator

Design sequence No.

LCD display

Electronic type

3. Technical data

Power supply	Internal power supply
Battery life	Approximately 6 years (25°C)
Display mode	LCD display, zero elimination type (zero display type available upon request)
Output mode	Without output
Time accumulation range	1: 99999.9h; 2: 99h59min59s; 3: 9999h59min; 4: 9999day23h; 5: 9999h59min59s; 6: 999999h59min59s;
Without voltage input	Maximum contact on resistance: ≤10kΩ (time accumulation ON); minimum contact off resistance: ≥500kΩ (time accumulation OFF) 0.5V Maximum input residual voltage: 0.5V
DC voltage input	L : DC0V-2V H : 4V-30V (H active) (input impedance : ≥4.7kΩ)
AC voltage input	AC/DC 24V~240V
Reset mode	Panel push-button reset (6-digit), external terminal reset (6-digit & 8-digit)
Minimum reset pulse width	≥0.2s
Time accumulation error	≤0.01%
Ambient temperature	-5°C~+40°C
Mounting type	Panel type
Overall dimensions	W48×H24×L52.9mm
Opening size	W45×H22.5mm

4. Wiring diagram

SC3L (without voltage input)

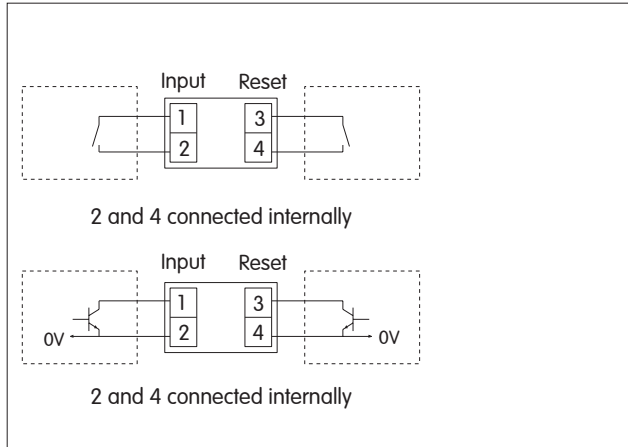

SC3L (DC voltage input)

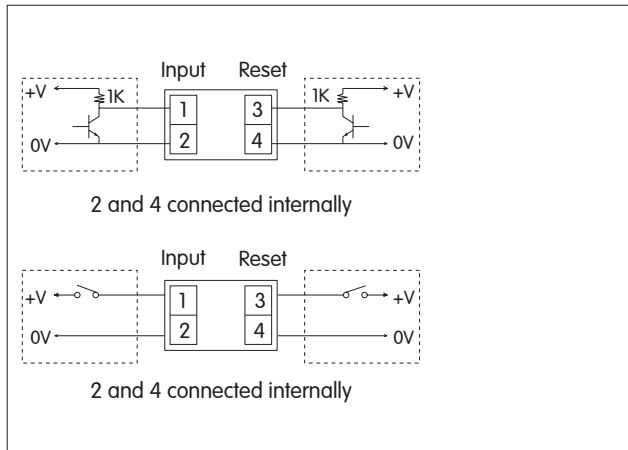

SC3L (AC voltage input)

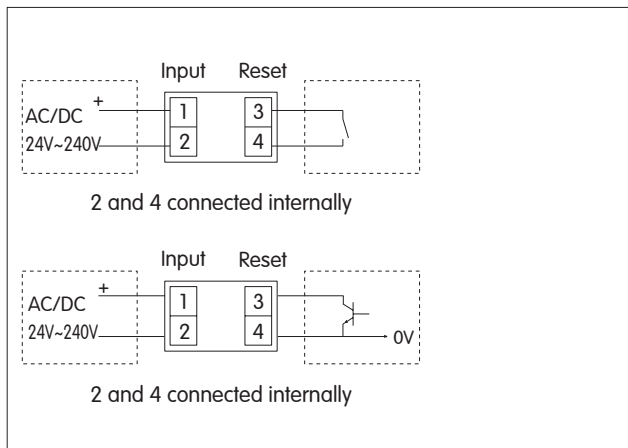

5. Overall dimensions

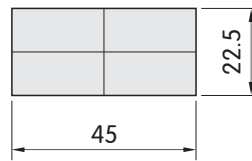
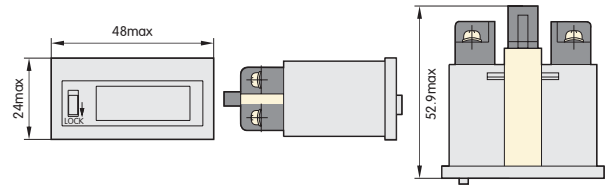



NKG3 Time Control Switch

1. General

NKG3 time control switch (hereinafter referred to as time control switch) is used in automatic control circuits with a frequency of AC 50Hz, a rated control supply voltage of up to 220V and a rated operational current of 3A to provide timed on-off control for street lamps, advertising lamps and similar equipment.

2. Type designation

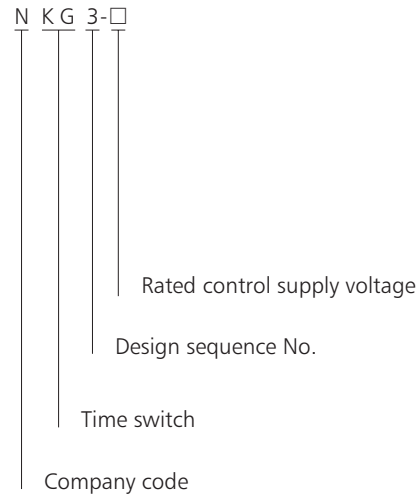

3. Technical data

Rated control supply voltage	AC(50Hz) 220V
Conventional heating current	16A
Usage category of auxiliary circuit	AC-15
Rated operational current (Ie)	AC-15 220V 3A
Timing error	≤2 seconds/day
Time control range	1min~24h
Mechanical life	≥30 thousand times
Electrical life	≥10 thousand times
Mounting type	Installation type, rail type
Immunity	See Table 2

Item	Severity level
Electrostatic discharge immunity	±8×(1±10%)kV (air discharge)
Radiated electromagnetic field immunity	Test electric field strength: 10×(1±10%)V/m
Fast transient immunity	For power line, 2kV, for I/O signal and control circuits, 1kV, duration: 1min
Surge (impact) immunity	Open circuit test voltage: 2×(1±10%)kV

4. Overall and mounting dimensions (mm)

4.1 Profile and installation dimension

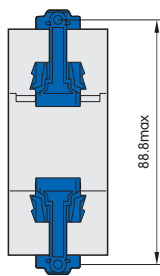
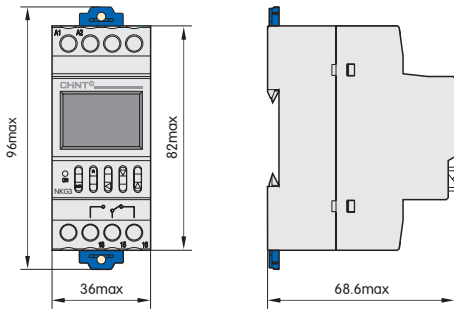

4.2 Connection mode

4.2.1 Direct control mode

If the electrical apparatus under control is single-phase supplied and has an operational current not greater than the rated value of the switch, direct control mode can be used, as shown in Figure 1. For lamp loads with a large starting impulse current, AC contactor expansion control mode should be used.

Figure 1 Connection diagram of single-phase direct control

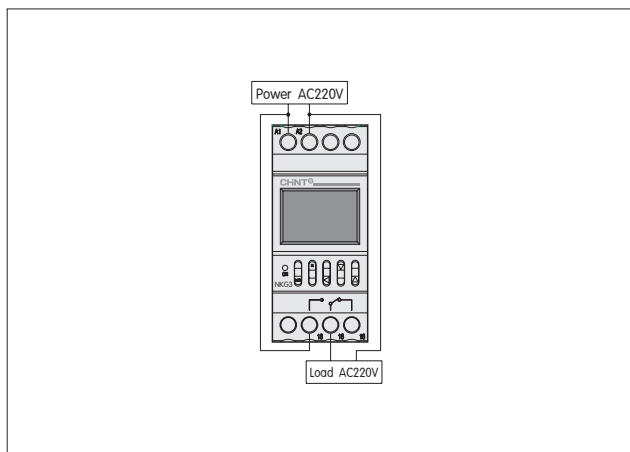

4.2.2 Single expansion mode

If the electrical apparatus under control is single-phase supplied and has an operational current greater than the rated value of the switch, AC contactor expansion control mode should be used, as shown in Figure 2.

Figure 2 Connection diagram of single-phase expansion control (contactor coil: 220V)

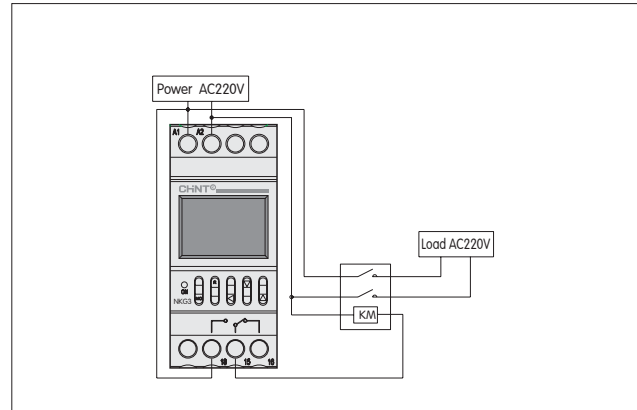

4.2.3 Three-phase operating mode

If the electrical apparatus under control is three-phase supplied, an external AC contactor is required.

a. If the coil voltage of the control contactor is AC220V 50Hz, the connection mode shown in Figure 4 should be used.

Figure 4 Connection diagram of three-phase control (contactor coil: 220V)

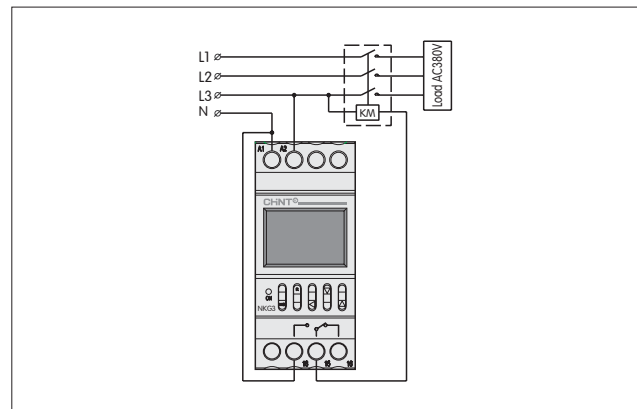

b. If the coil voltage of the control contactor is AC380V 50Hz, the connection mode shown in Figure 5 should be used.

Figure 5 Connection diagram of three-phase control (contactor coil: 380V)

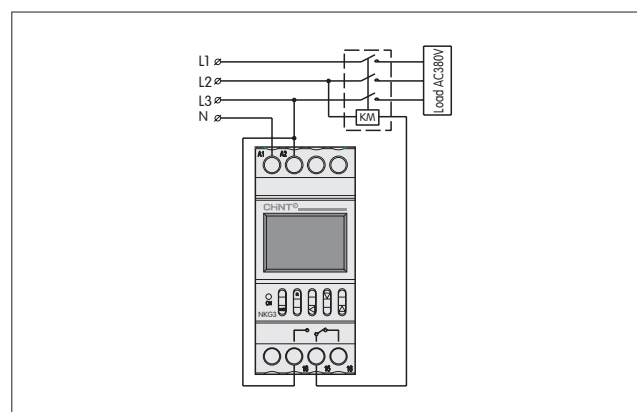



NKG2 Time Control Switch

1. General

NKG2 time control switch (hereinafter referred to as time control switch) is used in automatic control circuits with a frequency of AC 50Hz, a rated control supply voltage of up to 220V and a rated operational current of 0.75A to provide timed on-off control for street lamps, advertising lamps and similar equipment.

2. Type designation

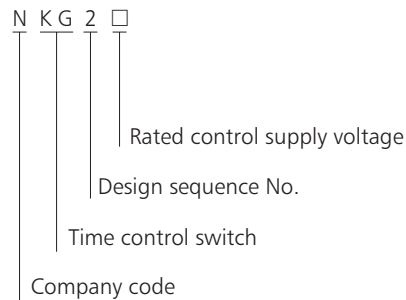

3. Technical data

Rated control supply voltage	AC(50Hz) 220V
Conventional heating current	5A
Usage category of auxiliary circuit	AC-15
Rated operational current (Ie)	AC-15 220V 0.75A
Timing error	≤2 seconds/day
Time control range	1s~168h
Mechanical life	≥30 thousand times
Electrical life	≥10 thousand times
Mounting type	Installation type, rail type
Immunity	See Table 2

Item	Severity level
Electrostatic discharge immunity	±8×(1±10%)kV (air discharge)
Radiated electromagnetic field immunity	Test electric field strength: 10×(1±10%)V/m
Fast transient immunity	For power line, 2kV, for I/O signal and control circuits, 1kV, duration: 1min
Surge (impact) immunity	Open circuit test voltage: 2×(1±10%)kV

4. Overall and mounting dimensions (mm)

4.1 Profile and installation dimension

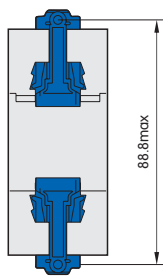
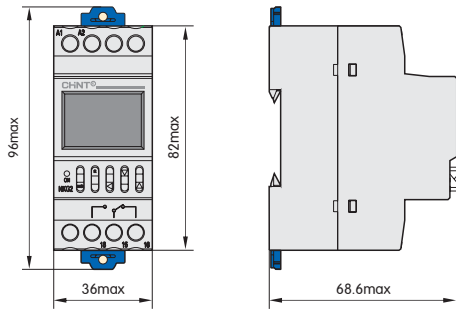

4.2 Connection mode

4.2.1 Direct control mode

If the electrical apparatus under control is single-phase supplied and has an operational current not greater than the rated value of the switch, direct control mode can be used, as shown in Figure 1. For lamp loads with a large starting impulse current, AC contactor expansion control mode should be used.

Figure 1 Connection diagram of single-phase direct control

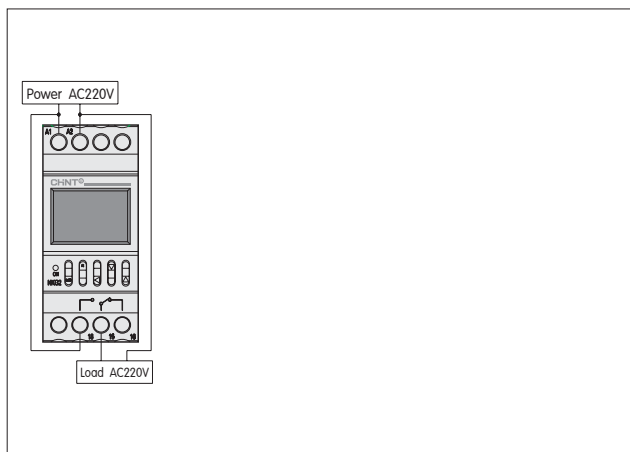

4.2.2 Single expansion mode

If the electrical apparatus under control is single-phase supplied and has an operational current greater than the rated value of the switch, AC contactor expansion control mode should be used, as shown in Figure 2.

Figure 2 Connection diagram of single-phase expansion control (contactor coil: 220V)

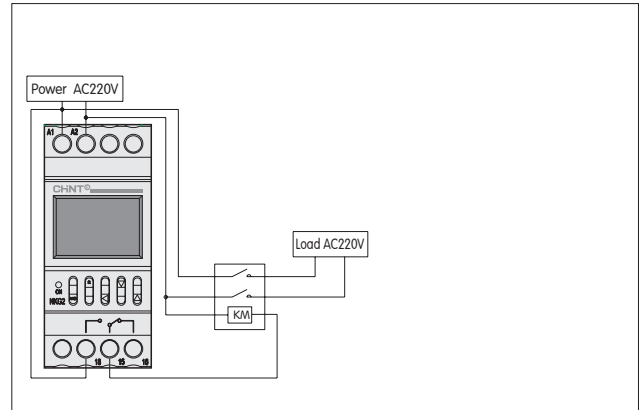

4.2.3 Three-phase operating mode

If the electrical apparatus under control is three-phase supplied, an external AC contactor is required.

a. If the coil voltage of the control contactor is AC220V 50Hz, the connection mode shown in Figure 4 should be used.

Figure 4 Connection diagram of three-phase control (contactor coil: 220V)

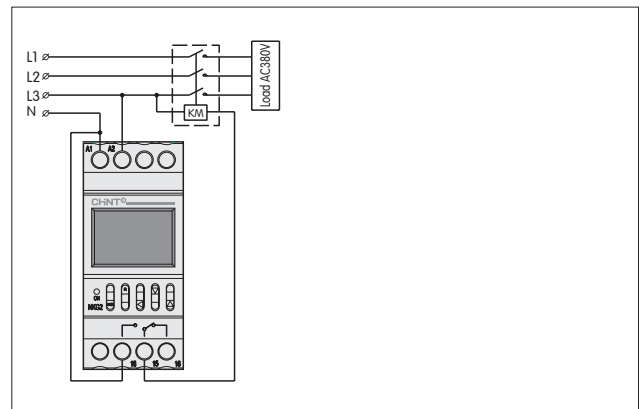

b. If the coil voltage of the control contactor is AC380V 50Hz, the connection mode shown in Figure 5 should be used.

Figure 5 Connection diagram of three-phase control (contactor coil: 380V)

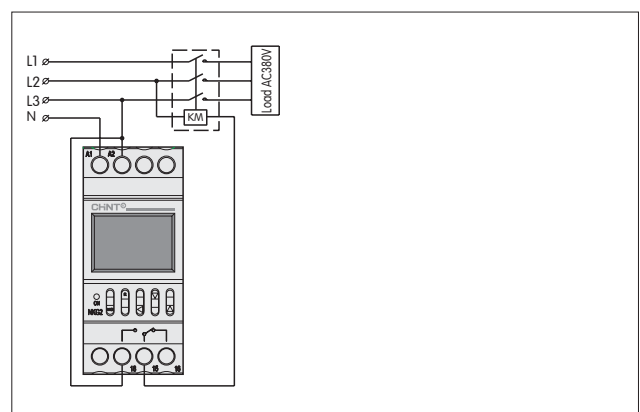



NKG1 Time Switch

1. General

NKG1 Time Switch is control element with time as control unit and can automatically turn on or turn off power supply of various consumer equipments according to preset time by user. The controlled objects are circuit equipments and household appliances such as street lamps, neon lamps, advertising lamps, manufacturing equipments, broadcast & television equipments, etc., which requires turning on and off at definite time.

2. Technical data

Operating mode	Time automatic control
Rated operating current	AC-15 3A
Rated operating voltage	AC220V 50Hz/60Hz
Electrical life	1×10^5
Mechanical life	1×10^6
Times of ON/OFF	16 opens & 16 closes
Battery	AA size battery (replaceable)
Timing error	$\leq 2s/day$
Ambient temperature	$-25^{\circ}C \sim +40^{\circ}C$
Installation mode	Guide rail type, wall-mounted type, unit style
External dimension	117.57×72.43×45.32

3. Wiring diagram

3.1 Wiring for direct control mode: direct control mode can be used for electrical apparatus which is single-phase power supply and its power consumption doesn't exceed rated value of this switch. See Figure 1 for wiring method;

3.2 Wiring for single-phase dilatancy mode: it is required a AC contactor with larger capacity than electrical apparatus power consumption for dilatancy when the controlled electrical apparatus is single-phase power supply, whereas its power consumption exceeds rated value of this switch. See Figure 2 for wiring method;

3.1.3 Wiring for three-phase operation mode: if the controlled electrical apparatus is three-phase power supply, it is required to externally connect three-phase AC contactor.

a. See Figure 3 for wiring, control contactor @ AC220V coil voltage, 50Hz;

b. See Figure 4 for wiring, control contactor @ AC380V coil voltage, 50Hz

Figure 1

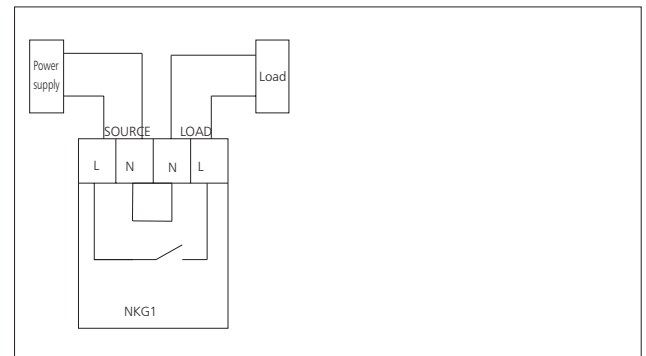

Figure 2

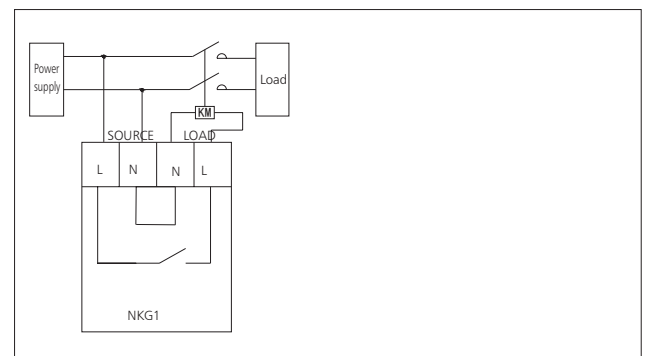

Figure 3

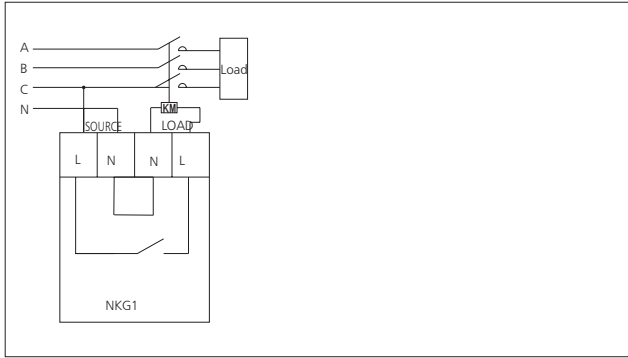
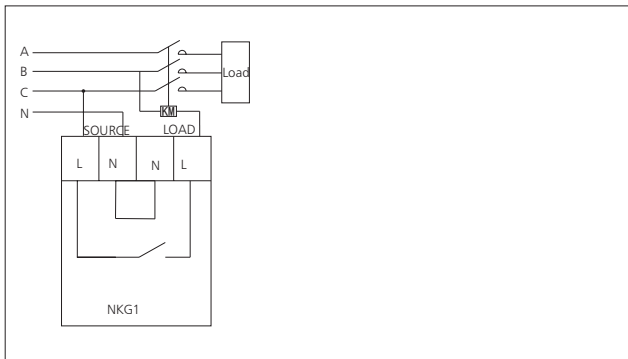
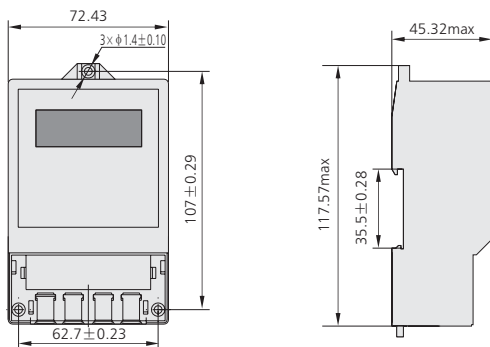

Figure 4



4. Overall and mounting dimensions (mm)

Profile installation dimensions





KG10D Time Switch

1. General

KG10D Microcomputer Time Switch can automatically turn on or turn off power supply of various consumer equipments according to preset time by user. The controlled objects are circuit equipments and household appliances such as street lamps, neon lamps, advertising lamps, manufacturing equipments, broadcast & television equipments, etc., which requires turning on and off at

2. Technical data

Operating mode	Time automatic control
Rated operating voltage	AC220V 50Hz/60Hz
Applicable voltage range	(85%~110%)Ue
Rated operating current	AC-15 220V 3A
Contact number	One group changeover or 1 ON
Electrical life	1×10^5
Mechanical life	1×10^6
Battery	Built-in rechargeable battery
Time control range	1 min~168h
Timing error	$\leq 2s/day$
Times of open/close	16 opens & 16 closes
Consumed power	< 4VA
Relative humidity	$\leq 95\%$
Ambient temperature	-25°C~+60°C
Installation mode	Guide rail type
External dimension	100.2×49.8×75.5

3. Wiring diagram

- 3.1 KG10D-1H is 1 ON and see Figure 4 for wiring method;
 3.2 KG10D-1Z is 1 ON/ 1 NC and see Figure 3 for wiring method;
 3.3 Wiring for single-phase direct control mode: direct control mode can be used for electrical apparatus which is single-phase power supply and its power consumption doesn't exceed rated value of this switch. See Figure 1 for wiring method;
 3.4 Wiring for three-phase operation mode: if the controlled electrical apparatus is three-phase power supply, it is required to externally connect three-phase AC contactor. See Figure 2 for wiring method for control contactor @ AC380V coil voltage, 50Hz.

Figure 1 single-phase load

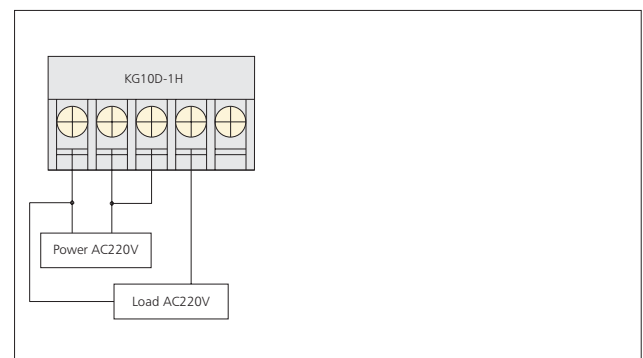

Figure 2 three-phase load

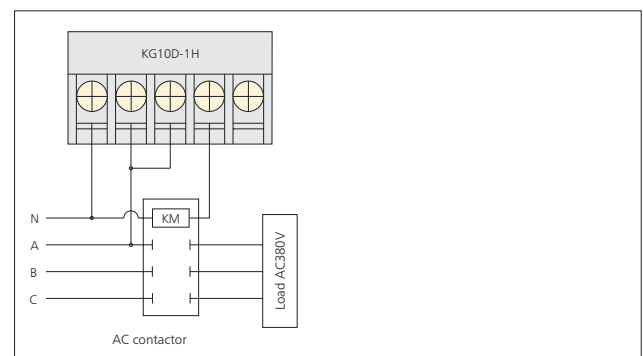

Figure 3 KG10D-1Z

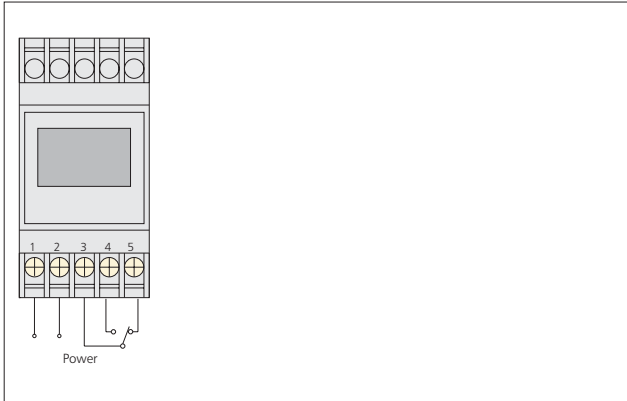
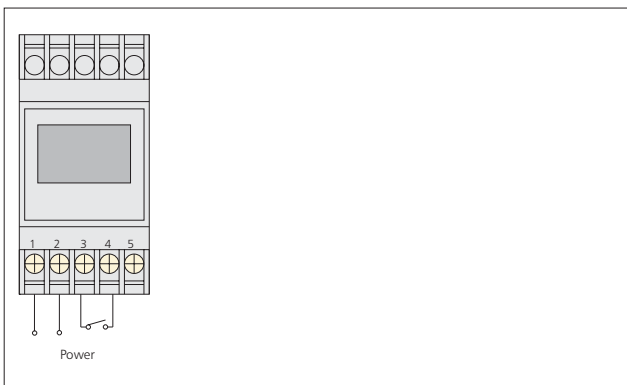
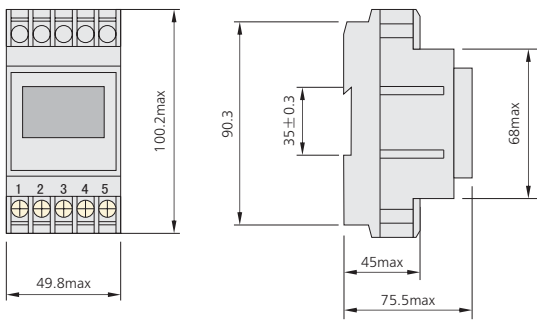

Figure 4 KG10D-1H



4. Overall and mounting dimensions (mm)

Profile installation dimensions





KG10M Time Switch

1. General

KG10M Time Switch can automatically turn on or turn off power supply of various consumer equipments according to preset time by user. The controlled objects are circuit equipments and household appliances such as street lamps, neon lamps, advertising lamps, manufacturing equipments, broadcast & television devices etc. Which requires turning on and off at definite time.

2. Technical data

Operating mode	Time automatic control
Rated operating voltage	AC220V 50Hz/60Hz
Applicable voltage range	(85%~110%)Ue
Rated operational current	AC-15 220V 3A
Contact number	1 NO
Times of ON/OFF	16-opens & 16-closes
Electrical life	1×10^5
Mechanical life	1×10^6
Battery	Internal Rechargeable Battery
Time-controlling range	1 min~168h
Timing error	$\leq 2s/day$
Consumed power	$< 4VA$
Relative humidity	$\leq 95\%$
Ambient temperature	$-25^{\circ}C \sim +60^{\circ}C$
Installation mode	Panel type
External dimension	$58.4 \times 52.4 \times 124.6$

3. Wiring diagram

Wiring diagram

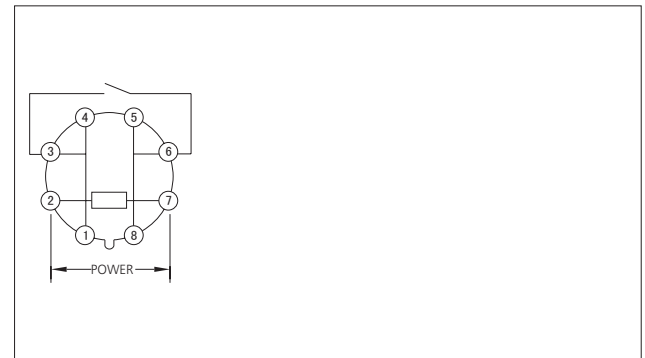

4. Overall and mounting dimensions (mm)

Profile installation dimensions

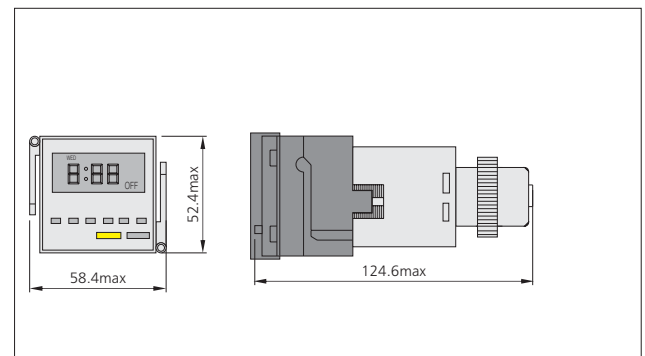

Opening size

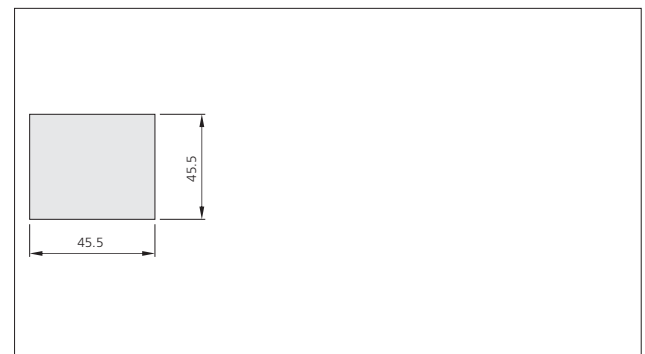



KG316T Time Switch

1. General

KG316T Time Switch can automatically turn on or turn off power supply of various consumer equipments according to preset time by user. The controlled objects are circuit equipments and household appliances such as street lamps, neon lamps, advertising lamps, manufacturing equipments, broadcast & television equipments, etc., which requires turning on and off at definite time.

2. Technical data

Operating mode	Time automatic control
Rated operating current	AC-15 3A
Rated operating voltage	AC220V 50Hz/60Hz
Applicable voltage range	(85%~110%)Ue
Rated output voltage	AC220V±1%
Electrical life	1×10 ⁵
Mechanical life	1×10 ⁶
Times of ON/OFF	8 opens & 8 closes, 16 opens & 16 closes
External dimension	121.32×74.73×50.77

3. Function features

- 3.1 "AA" size battery, replaceable;
- 3.2 Max set times per day (8 opens & 8 closes, 16 opens & 16 closes) and select according to requirements;
- 3.3 On-off time may cycle according to day or week;
- 3.4 Equipped with keyboard locking function for error operation protection;
- 3.5 Adopt single key operation in all, easy to install and adjust;
- 3.6 Timing error ≤2s/day.

4. Wiring diagram

- 4.1 Wiring for direct control mode: direct control mode can be used for electrical apparatus which is single-phase power supply and its power consumption doesn't exceed rated value of this switch. See Figure 1 for wiring method;
- 4.2 Wiring for single-phase dilatancy mode: it is required a AC contactor with larger capacity than electrical apparatus power consumption for dilatancy when the controlled electrical apparatus is single-phase power supply, whereas its power consumption exceeds rated value of this switch. See Figure 2 for wiring method;
- 4.3 Wiring for three-phase operation mode: if the controlled electrical apparatus is three-phase power supply, it is required to externally connect three-phase AC contactor;
- a. See Figure 3 for wiring, control contactor @ AC220V coil voltage, 50Hz;
- b. See Figure 4 for wiring, control contactor @ AC380V coil voltage, 50Hz.

Figure 1

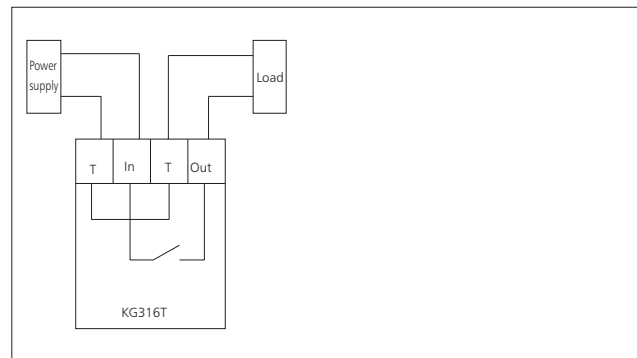

Figure 2

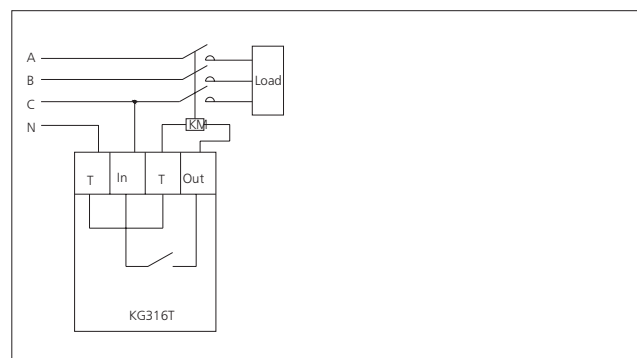

Figure 3

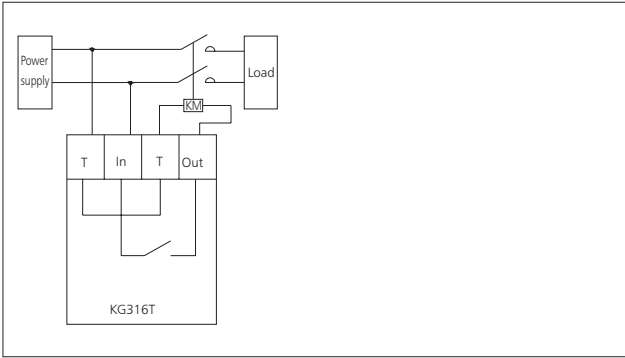
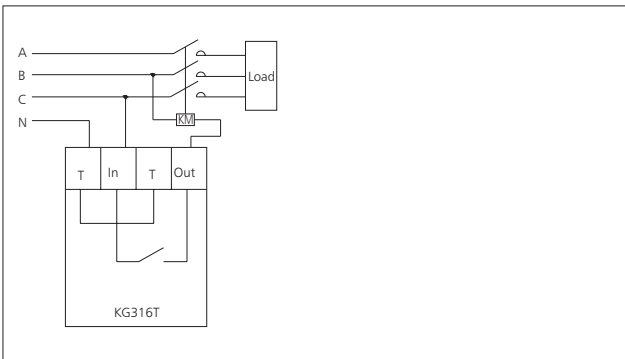
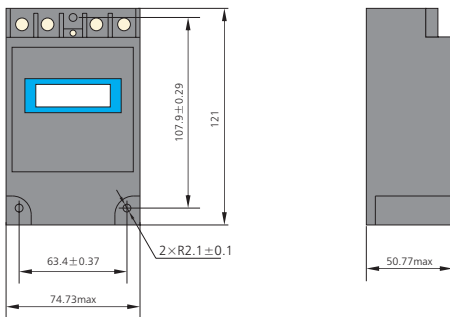

Figure 4



5. Overall and mounting dimensions (mm)

Profile installation dimensions





NJYW1 Floatless Relay

1. General

NJYW1 Series Floatless Relay is used in control circuit @ A.C. 50Hz/60Hz, up to 380V rated supply voltage for liquid level automatic control at places of civil water tower, high cistern, and underground conservation pool, etc. It is capable to realize automatic water supply control or water drainage control according to wiring requirement of user.

This product is not applicable for level control for liquid with poor conductivity such as oil, pure water, flammable & explosive chemical liquid and high density sewage, etc.

2. Type designation

N JYW 1 - □ □ / □

- Rated power supply voltage
- Length of electrode lead-wire:
L1: represents the max length of lead-wire is 1km
L2: represents the max length of lead-wire is 2km
- Function code:
N: water supply, water drainage type
B: water supply and water drainage with anti-exhausted of pump type
- Design sequence No.
- Floatless relay
- Company code

3. Technical data

Type	NJYW1-NL1	NJYW1-NL2	NJYW1-BL1	NJYW1-BL2
Operating mode	Continuous working			
Contact number	One group changeover contact			
Operating voltage	AC 50Hz/60Hz 36V, 110V/220V, 220V/380V		AC 50Hz/60Hz 36V, 110V, 220V, 380V	
Control electrode voltage	24V			
Conductor length	Max 1km	Max 2km	Max 1km	Max 2km
Operating resistance	≤25kΩ			
Releasing resistance	≥2kΩ			
Response time	Reacting: max 80ms; releasing: max 160ms			
Ambient temperature	-5°C~+40°C			
Power consumption	<3VA			
Installation mode	Guide rail type or device type			

4. Wiring diagram

Wiring diagram for NJYW1-NL1, NJYW1-NL2
water supply mode 110V/220V

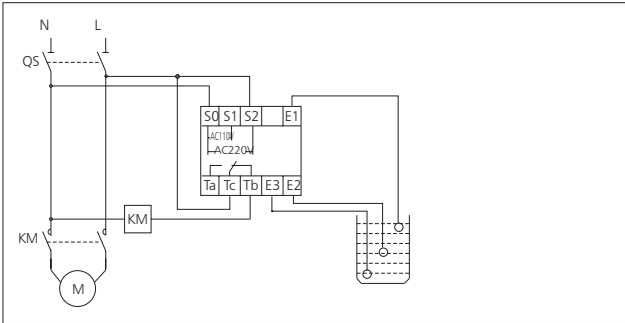

Wiring diagram for NJYW1-NL1, NJYW1-NL2
water drainage mode 110V/220V

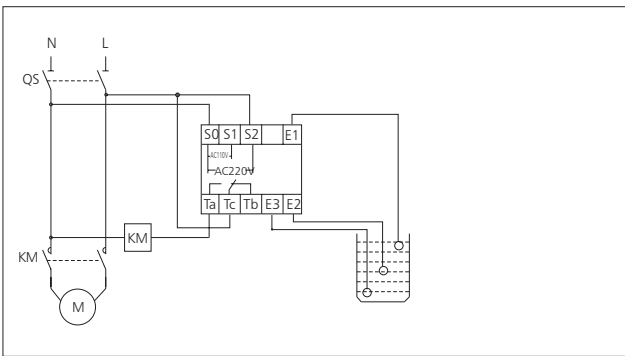

Wiring diagram for NJYW1-NL1, NJYW1-NL2
water supply mode 220V/380V

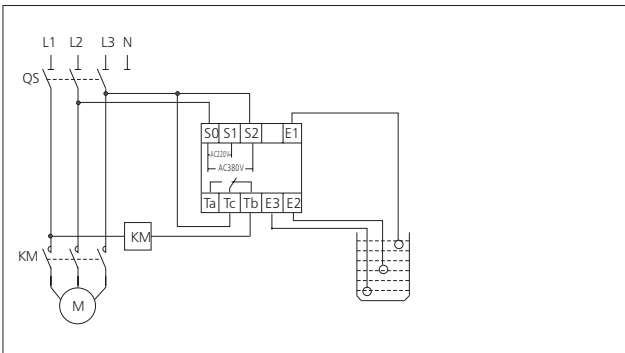

Wiring diagram for NJYW1-NL1, NJYW1-NL2
water drainage mode 220V/380V

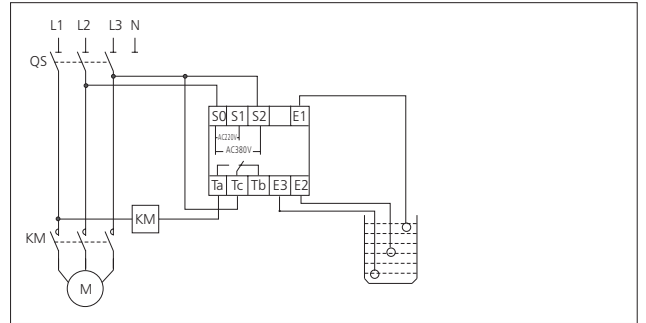

wiring diagram for NJYW1-BL1 and NJYW1-BL2
upper/lower water pool level control 220V

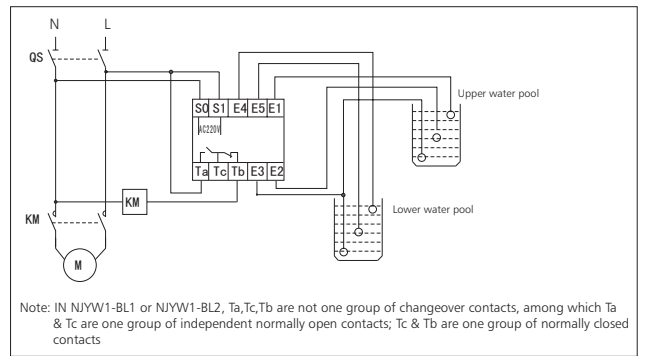

wiring diagram for NJYW1-BL1 and
NJYW1-BL2 upper/lower water pool level control 380V

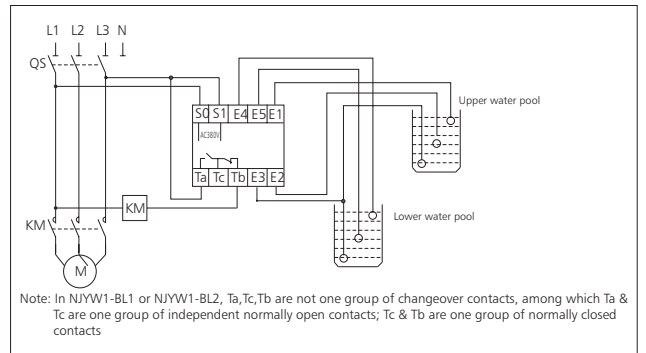

5. Overall and mounting dimensions (mm)

Profile and installation dimensions for NJYW1-NL1,
NJYW1-NL2, NJYW1-BL1, and NJYW1-BL2

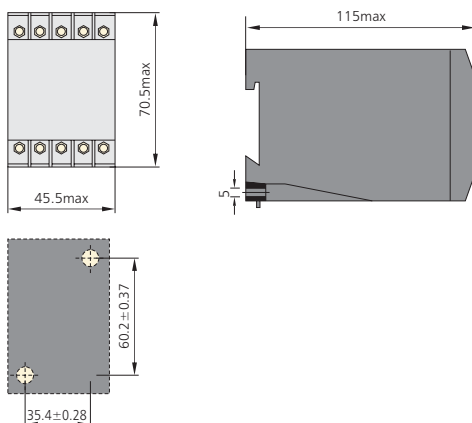

Note: NJYW1-BL1 & NJYW1-BL2 can be used as water supply or water drainage control independently, its wiring diagram referring to NJYW1-NL1.



JYB-714 Floatless Relay

1. General

JYB-714 Series Floatless Relay is used in liquid level automatic control circuit @ AC 50Hz/60Hz, up to 380V rated supply voltage for liquid level automatic control at places of civil water tower, high cistern, and underground conservation pool etc.

2. Type designation

JYB-714 □

Design sequence No.: Nil: Basic type
Type B: with reacting indicator;
Type C: with "water supply"; "drainage" reacting indicator

Floatless Relay

3. Technical data

Type	JYB-714	JYB-714B	JYB-714C
Operating mode	Continuous working		
Contact number	One group of changeover contact		
Operating voltage	AC 50Hz/60Hz 36V, 110V, 220V, 380V (other voltage can be custom made)		
Control electrode max current	50 μ A		
Conductor length	Max 1km		
Ambient temperature	-5℃ ~ +40℃		
Power consumption	<3VA		
Installation mode	Device type or guide rail type		

4. Wiring diagram

Wiring diagram for JYB-714, JYB-714B, JYB-714C
220V water supply mode

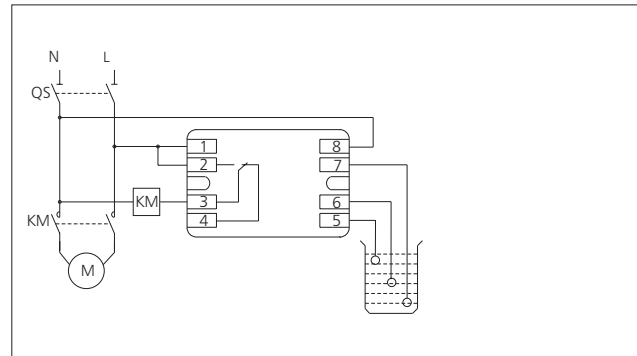

Wiring diagram for JYB-714, JYB-714B, JYB-714C
380V water supply mode

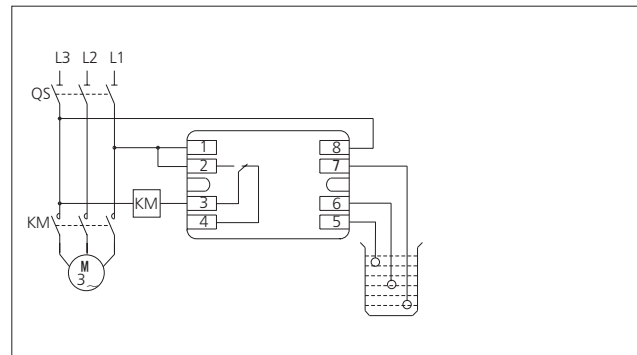

Wiring diagram for JYB-714, JYB-714B, JYB-714C
220V water drainage mode

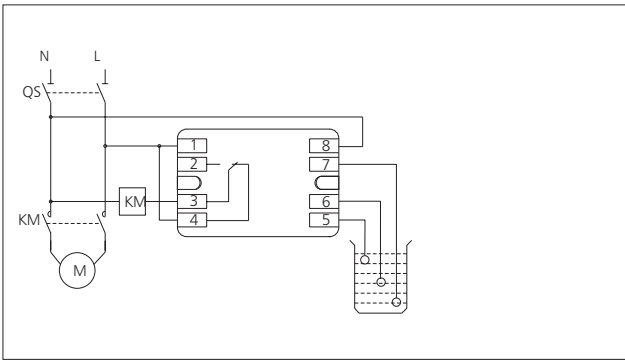

Wiring diagram for JYB-714, JYB-714B, JYB-714C
380V water drainage mode

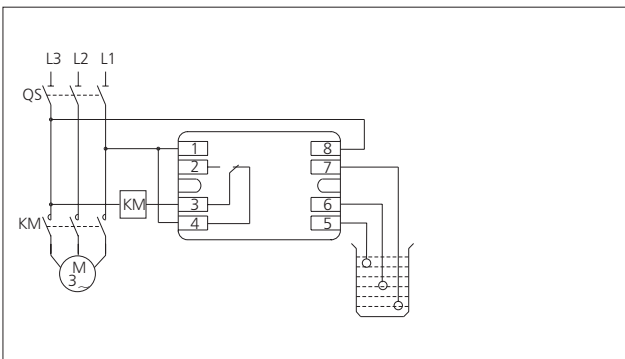

JYB-714C profile and installation dimensions

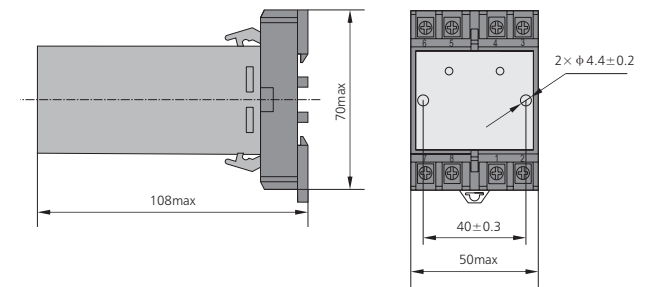

5. Overall and mounting dimensions (mm)

JYB-714 profile and installation dimensions

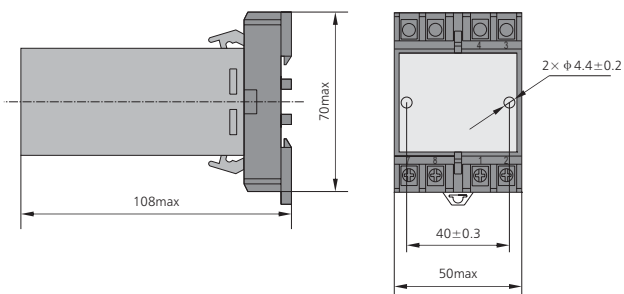

JYB-714B profile and installation dimensions

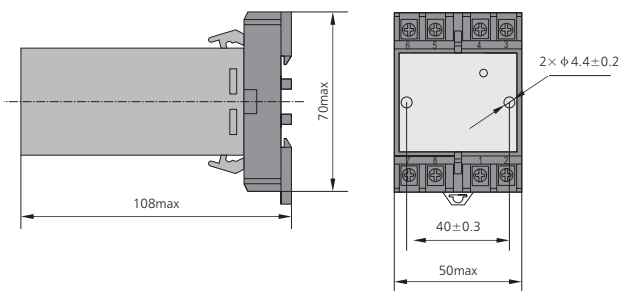



ZHEJIANG CHINT ELECTRICS CO.,LTD.

Add: No. 1, CHINT Road, CHINT Industrial Zone, North Baixiang,
Yueqing, Zhejiang, 325603, P.R.China

Tel: +86-577-62877777

Fax: +86-577-62775769 62871811

E-mail: global-sales@chint.com

Website: www.chint.net



Jul 2011