

Photo sensor
PL-D2B

INSTRUCTION MANUAL

Thank you for purchasing HANYOUNG product.
Please check whether the product is the exactly same as you ordered.
Before using the product, please read this instruction manual carefully.
Please keep this manual where you can view at any time

HANYOUNG NUX CO.,LTD
1381-3, Juan-Dong, Nam-Gu Incheon, Korea.
TEL:(82-32)876-4697
FAX:(82-32)876-4696
http://www.hynux.net

PT. HANYOUNG ELECTRONIC INDONESIA
JL.CEMPAKA BLOK F 16 NO.02 DELTA SILICON II
INDUSTRIAL PARK
LIPPO CIKARANG CICAU, CIKARANG PUSAT BEKASI
17550 INDONESIA
TEL : 62-21-8911-8120~4 FAX : 62-21-8911-8126

HANYOUNG NUX



Safety information

Before using the product, please read the safety information thoroughly and use it properly. Alerts declared in the manual are classified to Danger, Warning and Caution by their criticality

DANGER	DANGER indicates an imminently hazardous situation which, if not avoided, will result in death or serious injury
WARNING	WARNING indicates a potentially hazardous situation which, if not avoided, could result in death or serious injury
CAUTION	CAUTION indicates a potentially hazardous situation which, if not avoided, may result in minor or moderate injury

Warning

- If you do not follow instruction in this manual, injury or damage of property may occur.
- Please do not use outdoor
(It may cause of shorten the life of the product or electric shock).
- Do not use flammable, explosive gas environments.
Please do not use this product at any place where have over specification of vibration and shock.
- Please use a dry cloth to wipe off dusts and do not use thinner or solvent.
- Power switch and fuse are not attached to this product. Please install them separately on the outside.

Caution

- When cleaning the lens and the case, please use a dry cloth and gently wipe the surface. Must not use solvents such as thinner or alcohol.
- The sensor wire should be separate from high voltage line or power line. Having the same pipe for wiring can be cause of malfunction.
- This product has (IP 65) water proof structure but do now use permanent underwater place.
- When extending the cable, please use thick wire (at least thickness 1mm) and at this moment, please watch out for the voltage-drop.
- When using the sensor under the light such as fluorescent lighting or mercury lamp with high frequency, please block it with a light rap and avoid the lens from facing the light directly.
- When 2 units of through beam type of photo sensor are used, it can be cause of malfunction due to interference. Please make enough space and please install the receiver and emitter positions are crossed.
- In case of use Inductive load (relay, coil), the instantaneous load increases 2 times and it may break TR. So, please set maximum load at half.
- Output has over current protection circuit so it blocks output when output is higher than rated load current. So please set 70% from the maximum load.
- A lot of dusts pollute lens and it may cause of malfunction so please avoid using this product dust area.
- Information in the manual may changed without prior notification.
- When using the switching power supply as the power source, earth the frame ground (F.G) terminal and be sure to connect the noise eliminating condenser between 0 V and F.G.

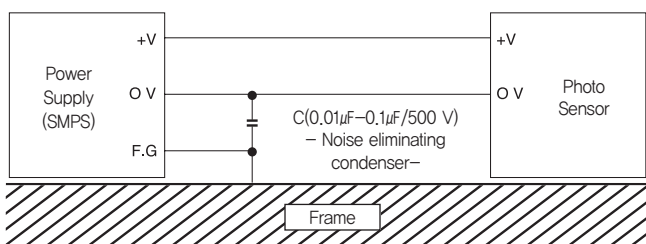

※ Not following safety issues which stated above may cause product to break down so users must follow them.

Characteristic

- Distance Setting type and BGS (Background suppression) function.
- Stable detection is possible without influence color & quality of detection object.
- Long detection distance (2 m) and can be applied in various fields.
- Built in the reverse connection of power protecting circuit and built in the output break protecting circuit
- IP65 Protective structure(IEC)

Specification

Model	PL - D2B
Sensing method	Distance-settable
Sensing distance	0.2 ~ 2 m
Sensing object	200 X 200 mm White paper with no gloss
Power supply voltage	12 - 24 V d.c ±10 %
Current consumption	30 mA max.
Control output	NPN / PNP open collector asynchronously, Load current : 150 mA d.c max. (Resistive load) NPN residual voltage : 1 V d.c max., PNP residual voltage : 2 V d.c max
Operation mode	Light ON / Dark ON ※ Selectable by the mode V/R
Response time	2 ms max.
Hysteresis	Less than 10 % of the sensing distance
Light source (Wave length)	Infrared lightening LED (880 nm)
Receiving part	2 photo diodes
Display	Control out display : Red LED, Stability display: Green LED
Distance setting	Near/Far : Optical distance adjusting volume 5 cycles.
Protective circuit	Power reverse connection protecting circuit and output break protecting circuit
Ambient illumination	Sunlight : 11,000 lx max., Incandescent lamp : 3,000 lx max.
Ambient temperature	Operation : -20 ~ 60 °C, Storage : -25 ~ 70 °C (Without freezing)
Ambient humidity	35 ~ 85 % RH (Without condensation)
Protective structure	IP 65
Insulation resistance	20 MΩ min.(500 V d.c Mega)
Dielectric strength	1000 V a.c (50/60 Hz for 1 min)
Vibration resistance	10 - 55 Hz, Double amplitude : 1.5 mm for 2 hours each in X, Y and Z directions.
Shock resistance	500 % 3 times each in X, Y and Z directions.
Connection method	Cable output type, Number of wires : 4P, Thickness : Ø 4 mm, Length 2 m
Material	Case : PC, Lens : PC
Accessory	Bracket, Adjustable driver, bolt, Nut.

Dimension

[Unit : mm]

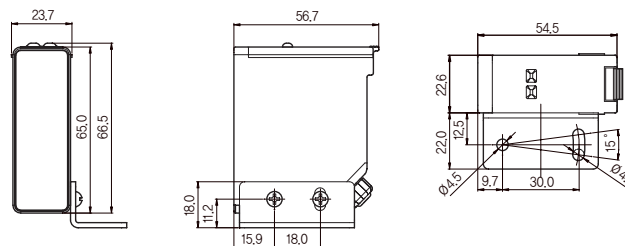

Connection diagram

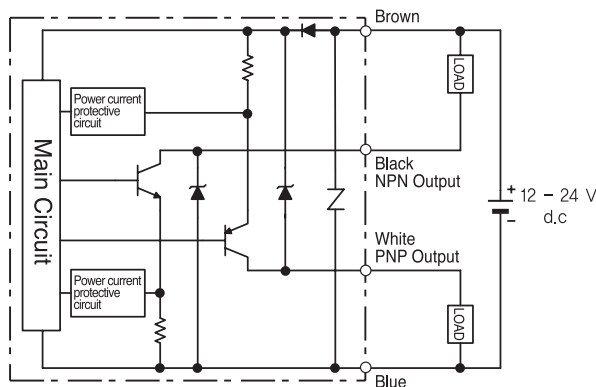

Name of each part

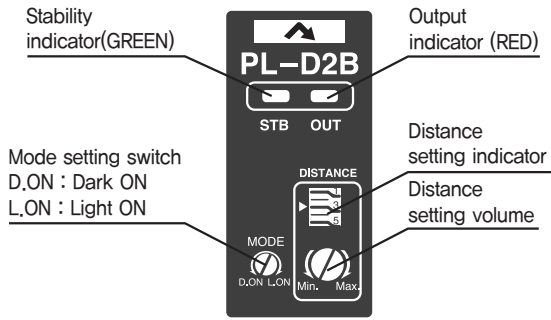

Characteristic of sensing distance

- Colored paper sensing distance

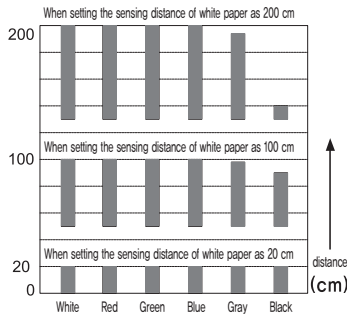

- Material sensing distance

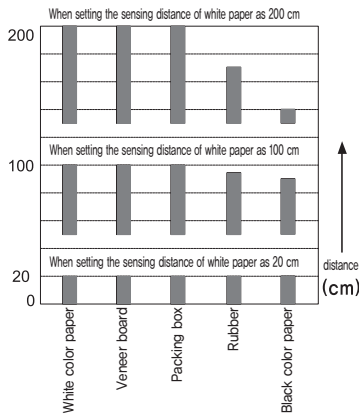

Operation chart

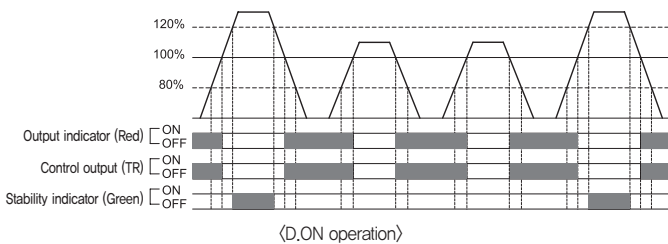
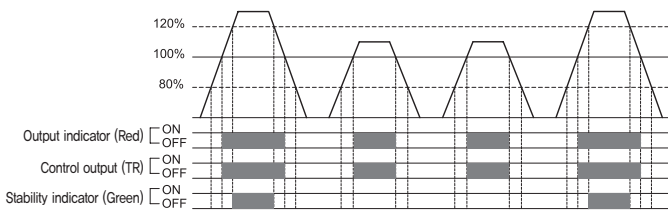

Stability indicator becomes ON when an amount of light exceed the operation level and becomes 120% (stable L,ON area). It can be used as the environmental change after setup or level down during operation and initial operation check.

How to set the distance

No	How to set the distance	Setting state	Indicator for display the setting distance
1	Remove the sensing object and turn the distance setting volume to Max direction until right before the operation indicator becomes ON. Here, we will refer this position as the position A. If operation indicator does not become ON then we will refer the maximum position as A.		
2	Place the sensing object in the sensing position and check whether the operation indicator and stability indicator become ON. After inspecting such things, turn the setting volume to Min direction until the operation indicator becomes OFF. We will refer this position as the position B.		
3	Set the indicator of distance setting to fall in between A and B by turning the distance setting volume to Max direction and checks whether it is operating properly. Here, if the stability indicator (green) does not become ON even after sensing a certain object then the cause is maybe due to the unstable sensing so please re-check the sensing method.		

Precautions during installation

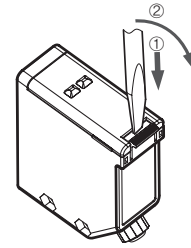

- Please use ⊖ driver as above picture when you detach top cover from the case.

* If an object with good reflectivity is in present under the photo sensor then operation may become unstable. Therefore, please slant the sensor and place it just like an image below or have a gap between the ground and sensor.

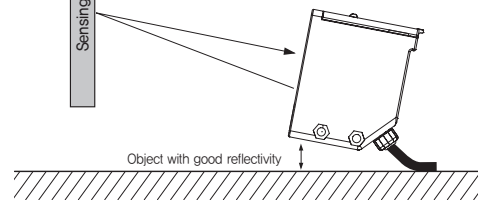

- Regarding the installation direction of photo sensor, please consider about the moving direction of sensing object and install it (please refer to an image below)

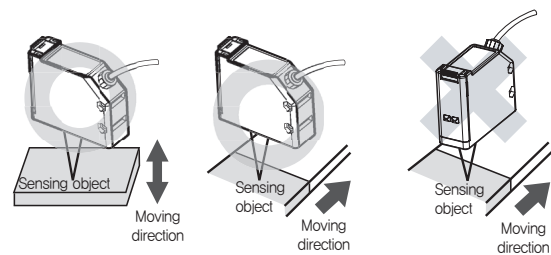

- Please do not let strong ray light such as sunlight, fluorescent light, incandescent lamp and etc to fall within the directional angle of photo sensor.
- When installing the photo sensor, do not apply strong force on it by using tools such as hammer and etc. Doing so may damage the internal functions.
- Please use M4 for screw
- The tightening torque of screw should be less than 1,2 N · m