

QA115LSE series

LED Strobe Warning Lights for Heavy-Duty Equipment



QA115LSE-Ø115mm



QA115LSE

QA115LSE LED Strobe Warning Lights

- LED Strobe warning lights for heavy-duty equipment applications, featuring superior luminous efficiency with Qlight's exclusive light diffusion system
- Ability to compensate for signal attenuation phenomenon that occurs during daytime operation with a powerful xenon lamp.
- Flashing rate : 60-80 flashes/min
- Materials : Lens-PC, Housing-PC
- Ambient operation temperature : -30°C to +50°C
- Protection rating : IP66
- Vibration resistant and shock-proof : Can withstand 15g of vibration and 100g of shock

Common Specifications

Model number	Voltage	Current	Certificates	Weight	Color
QA115LSE	DC12V-24V	Max 0.990A	-	1.01kg	● A-Amber

※ DC type model has a free-voltage range of 10V-30V.

Technical Diagram

(Units : mm)

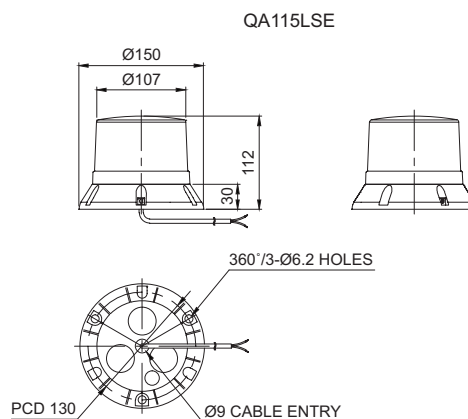

Wiring Instructions

- External power line standard - UL2464 18AWG×2C 400mm

Customization

- User selected connector type available upon request
- Built-in protection cage

Ordering Specification

QA115LSE	-	12/24	-	A
[Model number]		[Voltage]		[Color]
• QA115LSE		• 12/24-DC12V-24V		• A-Amber