

QA70HLS/ QA100HLS

LED Strobe Warning Lights for Heavy-Duty Equipment



QA70HLS-Ø70mm
QA100HLS-Ø100mm



QA70HLS



QA100HLS



Common Specifications(QA70HLS/ QA100HLS)

- Uses Qlight's original high brightness LED diffusion system that allows for operation outdoors in intense sunlight conditions
- Excellent vibration and shock resistant structure for superior durability
- Fully enclosed structure that can withstand storm and severe dust environments (IP66)
- Materials : Lens-PC, Housing-ABS+GF(for QA70HLS)/ ABS(for QA100HLS)
- Ambient operating temperature : -30°C to +50°C
- Protection rating : IP66
- Vibration resistant and shock-proof : can withstand 15g of vibration and 100g of shock



QA70HLS LED Strobe Warning Light

- Mountable with two bolts on the main structure of the warning light for convenient assembly
- Suitable for small agricultural machines
- Flashing rate : 45-55 flashes/min

Model number	Voltage	Current	Certificates	Weight	Color
QA70HLS	DC12V-24V	Max 0.620A	-	0.23kg	<ul style="list-style-type: none"> • R-Red • A-Amber

※ DC type model has a free-voltage range of 10V-30V.



QA100HLS LED Strobe Warning Light

- Flashing rate : 60-80 flashes/min

Model number	Voltage	Current	Certificates	Weight	Color
QA100HLS	DC12V-24V	Max 1.200A	CE	0.39kg	<ul style="list-style-type: none"> • R-Red • A-Amber

※ DC type model has a free-voltage range of 10V-30V.



Technical Diagram

(Units : mm)

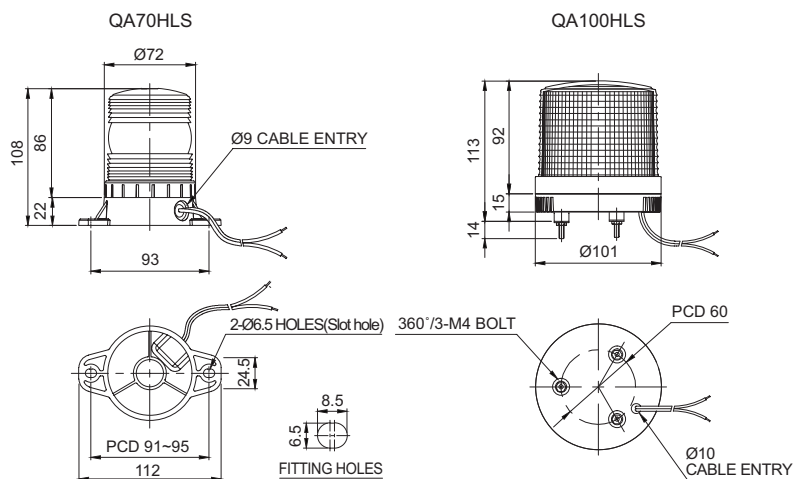

Wiring Instructions

- QA70HLS Model : External power line standard UL1015 AWG18(0.75sq)×2C 400mm
- QA100HLS Model : External power line standard KSC3304 0.85sq×2C 400mm
- Both models can be wired regardless of polarity



Ordering Specification

QA100HLS	-	12/24	-	R
[Model number]		[Voltage]		[Color]
<ul style="list-style-type: none"> • QA70HLS • QA100HLS 		<ul style="list-style-type: none"> • 12/24-DC12V-24V 		<ul style="list-style-type: none"> • R-Red • A-Amber