

RU3110

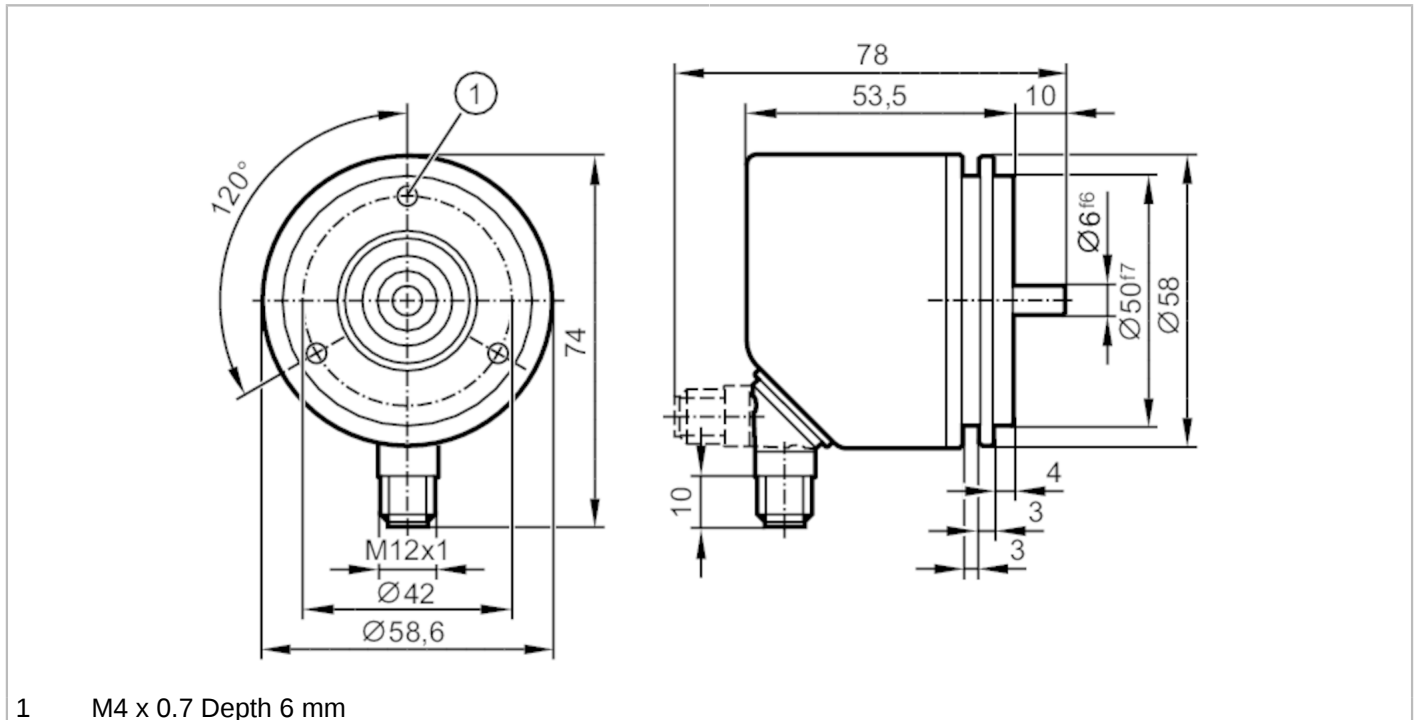

Incremental encoder with solid shaft

INCREMENTAL ENCODER



1 M4 x 0.7 Depth 6 mm

CE EAC IO-Link

Product characteristics

Resolution	1...10000; (parameterisable; Factory setting: 1024) resolution
Communication interface	IO-Link
Shaft design	solid shaft
Shaft diameter [mm]	6

Application

Function principle	incremental
Detection system	magnetic

Electrical data

Operating voltage [V]	4.75...30 DC
Current consumption [mA]	< 150
Protection class	III
Reverse polarity protection	yes
Power-on delay time [s]	0.5
Max. revolution electrical [U/min]	12000

Outputs

Electrical design	HTL/TTL
Switching frequency [kHz]	1000
Factory setting	Output function: HTL (50 mA)
Short-circuit protection	yes
Phase difference A and B [°]	90

Measuring/setting range

Resolution	1...10000; (parameterisable; Factory setting: 1024) resolution
------------	--



Incremental encoder with solid shaft

INCREMENTAL ENCODER

Accuracy / deviations	
Accuracy	[°] 0.1
Software / programming	
Parameter setting options	Resolution; direction of rotation; HTL; TTL
Interfaces	
Communication interface	IO-Link
Transmission type	COM2 (38,4 kBaud)
IO-Link revision	1.1
SIO mode	yes
Min. process cycle time	[ms] 2.3
Operating conditions	
Ambient temperature	[°C] -40...85
Storage temperature	[°C] -40...85
Max. relative air humidity	[%] 95; (condensation not permissible)
Protection	IP 67; (on the housing: IP67; on the shaft: IP67)
Tests / approvals	
Shock resistance	100 g
Vibration resistance	20 g
Mechanical data	
Weight	[g] 596.5
Dimensions	[mm] Ø 58 / L = 63.5
Materials	flange: stainless steel (1.4571/316Ti); housing: stainless steel (1.4521 / 444); NBR
Max. revolution, mechanical	[U/min] 12000
Max. starting torque	[Nm] 1
Reference temperature torque	[°C] 20
Shaft design	solid shaft
Shaft diameter	[mm] 6
Shaft material	stainless steel (1.4571/316Ti)
Max. shaft load axial (at the shaft end)	[N] 40
Max. shaft load radial (at the shaft end)	[N] 60
Fixing flange	synchro-flange

Electrical connection

Connector: 1 x M12, radial, can also be used axially; Moulded body: stainless steel (1.4401 / 316); Maximum cable length: 100 m; (IO-Link: max. 20 m)

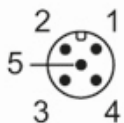

RU3110



Incremental encoder with solid shaft

INCREMENTAL ENCODER

IO-Link

1	L+
2	not to be used
3	L-
4	IO-Link
5	not to be used
Screen	plug

encoder

1	UB
2	A
3	GND
4	Z/0-Pulse (90 deg)
5	B
Screen	plug

Diagrams and graphs

Pulse diagram

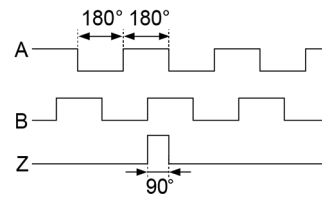

direction of rotation clockwise (looking at the shaft)