

RUP500



Incremental encoder with solid shaft and display

INCREMENTAL ENCODER PERFORMANCE LINE

Speed monitor		
Set point SP	-9994...9999 U/min	-166.6...166.7 Hz
Reset point rP	-9999...9994 U/min	-166.7...166.6 Hz
Counter		
Preset point	1...9999	
Accuracy / deviations		
Accuracy	[°]	0.1
Software / programming		
Parameter setting options	encoder; Resolution; Direction of rotation; HTL; TTL; Speed monitor; Resolution	
Interfaces		
Communication interface	IO-Link	
Transmission type	COM2 (38,4 kBaud)	
IO-Link revision	1.1	
SIO mode	yes	
Min. process cycle time	[ms]	2.3
Operating conditions		
Ambient temperature	[°C]	-40...85
Storage temperature	[°C]	-40...85
Max. relative air humidity	[%]	95; (Condensation not permissible)
Protection	IP 65; (on the housing: IP 67; on the shaft: IP 64)	
Tests / approvals		
Shock resistance		100 g
Vibration resistance		20 g
MTTF	[years]	218
Mechanical data		
Weight	[g]	437
Dimensions	[mm]	Ø 58 / L = 64
Material	flange: aluminum; housing: stainless steel; display window: PEI	
Max. revolution, mechanical	[U/min]	12000
Max. starting torque	[Nm]	1
Reference temperature torque	[°C]	20
Shaft design	solid shaft	
Shaft diameter	[mm]	6
Shaft material	stainless steel	
Max. shaft load axial (at the shaft end)	[N]	40
Max. shaft load radial (at the shaft end)	[N]	60
Fixing flange	Synchro-flange	
Displays / operating elements		
Display		10-segment display, red/ green 4-digit configurable
		2 x LED, yellow
		5 x LED, green

RUP500



Incremental encoder with solid shaft and display

INCREMENTAL ENCODER PERFORMANCE LINE

Electrical connection

Connector: 1 x M12, radial, can also be used axially; Moulded body: stainless steel; Maximum cable length: 100 m; (IO-Link: max. 20 m)

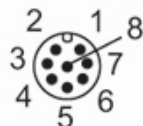

IO-Link

1	L+
2	not to be used
3	L-
4	IO-Link
5	not to be used
6	not to be used
7	not to be used
8	not to be used
screen	plug

encoder

1	UB
2	A
3	GND
4	Z/0-Pulse (90 deg)
5	B
6	A-
7	B-
8	Z-
screen	plug

Speed monitor

1	UB
2	OUT2
3	GND
4	not to be used
5	OUT1
6	OUT2-
7	OUT1-
8	not to be used
screen	plug

RUP500



Incremental encoder with solid shaft and display

INCREMENTAL ENCODER PERFORMANCE LINE

Preset counter

1	UB
2	IN1
3	GND
4	not to be used
5	OUT1
6	not to be used
7	not to be used
8	not to be used
screen	plug

Diagrams and graphs

Pulse diagram

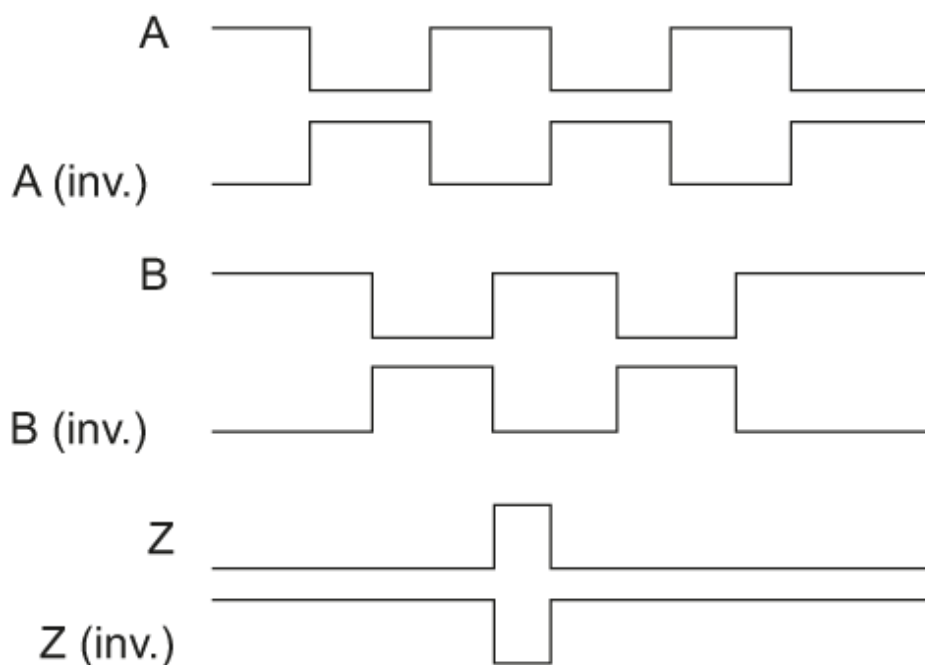

Direction of rotation clockwise (looking at the shaft)