

Ethernet LED Tower Light

ST45(M)L/ ST56(M)EL/ ST80(M)EL-ETN

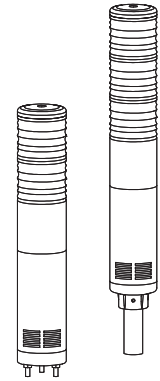

Thank you for purchasing Qlight's products. Please read this user manual carefully prior to installation and operation to ensure safe and correct use.

⚠ Precautions for Safety

Failure to follow the instructions below may cause a loss of life or serious physical injury.

1. During wiring or maintenance, please completely turn off the power of the product. (Failure to follow this may lead to an electric shock.)
2. Do not install the product in locations that subjects it to excessive dust or water other than the conditions designated by the IP protection ratings indicated for each product. (Failure to follow these instructions may cause a fire to the product, electric shock, physical injury, malfunction or damage to the product.)
3. Do not alter or repair this product. If maintenance or repair service is required, please contact your local Qlight contact point. (Failure to follow these instructions may lead to fire, electric shock, or product damage.)
4. Please apply the correct voltage to the product. (Failure to follow these instructions may lead to fire, electric shock, or product damage.)
5. When the product is applied to a condition that may impact lives or property, please make sure to have a double safety device. (Failure to follow this may cause damage to property, fire, electric shock and loss of life.)

⚠ Precautions for Correct Use

Failure to follow the proper instructions may cause damage to property, the product, or malfunction of the product that would void the warranty.

1. Please remove any objects that can interrupt ventilation around the product.
2. Please turn off the power of the product immediately if it fails to operate properly.
3. Carefully wire the product according to each product's specification.
4. Please be careful in preventing chemicals such as thinner, benzene, etc. in contact with the surface of the product.
5. Do not apply excessive force/impact to the product.
6. Failure to follow any of the instructions above may cause malfunction or damage to the product, fire, and electric shock.

Ordering Specifications

• ST45(M)L-ETN

ST45L-ETN-WS	3	24	RAG	LW18
[Model number]	[Layer]	[Voltage]	[Color]	[Mounting option]
• ST45L-ETN-BZ	• Layer1-1	• 12-DC12V	R-Red	• (Blank)
• ST45L-ETN-WS	• Layer2-2	• 24-DC24V	A-Amber	- Standard type
• ST45L-ETN-WM	• Layer3-3	• 110/220	G-Green	• Mounting type
• ST45L-ETN-WA	• Layer4-4	-AC110-220V	B-Blue	- LB18 - LW18
• ST45ML-ETN-BZ	• Layer5-5		W-White	- QZ18 - SZ18
• ST45ML-ETN-WS				- QL18 - SL18
• ST45ML-ETN-WM				- QLA18
• ST45ML-ETN-WA				

• ST56(M)EL-ETN

ST56EL-ETN-WS	3	220	RAG	LW18
[Model number]	[Layer]	[Voltage]	[Color]	[Mounting option]
• ST56EL-ETN-BZ	• Layer1-1	• 12-DC12V	R-Red	• (Blank)
• ST56EL-ETN-WS	• Layer2-2	• 24-DC24V	A-Amber	- Standard type
• ST56EL-ETN-WM	• Layer3-3	• 110/220	G-Green	• Mounting type
• ST56EL-ETN-WA	• Layer4-4	-AC110-220V	B-Blue	- LB18 - LW18
• ST56MEL-ETN-BZ	• Layer5-5		W-White	- QZ18 - SZ18
• ST56MEL-ETN-WS				- QL18 - SL18
• ST56MEL-ETN-WM				- QLA18
• ST56MEL-ETN-WA				



Please scan the QR code for more detailed product information.

www.qlight.com

Ordering Specifications

• ST80(M)EL-ETN

ST80EL-ETN-WS	3	220	RAG	LW24
[Model number]	[Layer]	[Voltage]	[Color]	[Mounting option]
<ul style="list-style-type: none"> • ST80EL-ETN-BZ • ST80EL-ETN-WS • ST80EL-ETN-WM • ST80EL-ETN-WA • ST80MEL-ETN-BZ • ST80MEL-ETN-WS • ST80MEL-ETN-WM • ST80MEL-ETN-WA 	<ul style="list-style-type: none"> • Layer1-1 • Layer2-2 • Layer3-3 • Layer4-4 • Layer5-5 	<ul style="list-style-type: none"> • 12-DC12V • 24-DC24V • 110-AC110V • 220-AC220V 	<ul style="list-style-type: none"> R-Red A-Amber G-Green B-Blue W-White 	<ul style="list-style-type: none"> • (Blank) - Standard type • Mounting type - LB24 - LW24 - QZ24 - SZ24 - QL24 - SL24 - QLA24

Product Specifications

• ST45(M)L-ETN

Model number	Layer	Voltage	Current	Certificate	Color
ST45L-ETN ST45ML-ETN	1	DC12V DC24V AC110V-220V	0.200A 0.135A Max. 0.053A	-	R-Red
	2	DC12V DC24V AC110V-220V	0.210A 0.145A Max. 0.056A		R-Red G-Green
	3	DC12V DC24V AC110V-220V	0.220A 0.155A Max. 0.058A		R-Red A-Amber G-Green
	4	DC12V DC24V AC110V-220V	0.230A 0.165A Max. 0.061A		R-Red A-Amber G-Green B-Blue
	5	DC12V DC24V AC110V-220V	0.240A 0.175A Max. 0.055A		R-Red A-Amber G-Green B-Blue W-White

• ST56(M)EL-ETN

Model number	Layer	Voltage	Current	Certificate	Color
ST56EL-ETN ST56MEL-ETN	1	DC12V DC24V AC110V-220V	0.215A 0.150A Max. 0.060A	CE	R-Red
	2	DC12V DC24V AC110V-220V	0.245A 0.170A Max. 0.065A		R-Red G-Green
	3	DC12V DC24V AC110V-220V	0.275A 0.190A Max. 0.070		R-Red A-Amber G-Green
	4	DC12V DC24V AC110V-220V	0.305A 0.210A Max. 0.075A		R-Red A-Amber G-Green B-Blue
	5	DC12V DC24V AC110V-220V	0.335A 0.230A Max. 0.080A		R-Red A-Amber G-Green B-Blue W-White

※ CE compliant : DC24V, AC110V-220V

• ST80(M)EL-ETN

Model number	Layer	Voltage	Current	Certificate	Color
ST80EL-ETN ST80MEL-ETN	1	DC12V DC24V AC110V-220V	0.230A 0.150A Max. 0.060A	-	R-Red
	2	DC12V DC24V AC110V-220V	0.260A 0.180A Max. 0.065A		R-Red G-Green
	3	DC12V DC24V AC110V-220V	0.290A 0.205A Max. 0.075A		R-Red A-Amber G-Green
	4	DC12V DC24V AC110V-220V	0.320A 0.230A Max. 0.085A		R-Red A-Amber G-Green B-Blue
	5	DC12V DC24V AC110V-220V	0.350A 0.255A Max. 0.090A		R-Red A-Amber G-Green B-Blue W-White

• Protection rating : IP23

• Ambient operating temperature : -30°C to + 50°C

ST45ML-ETN

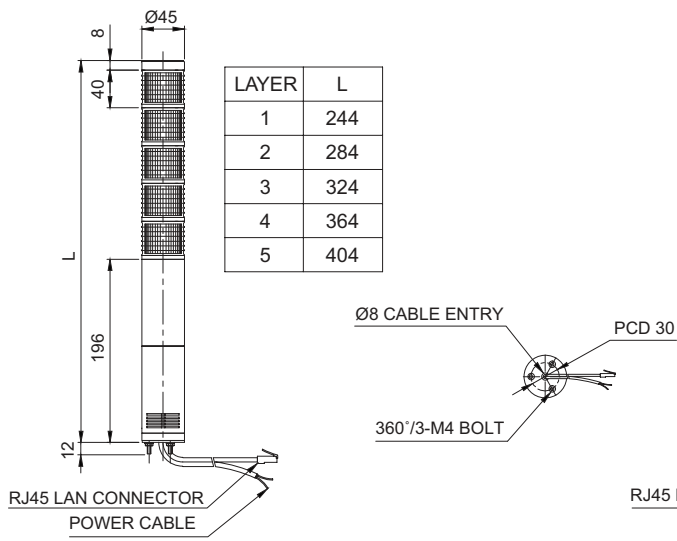

ST45L-ETN

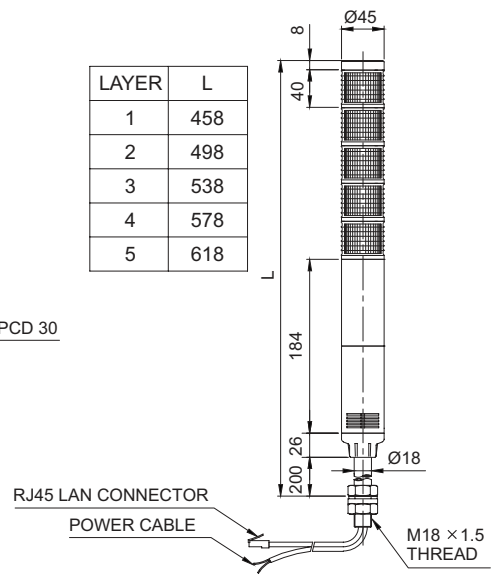

ST56MEL-ETN

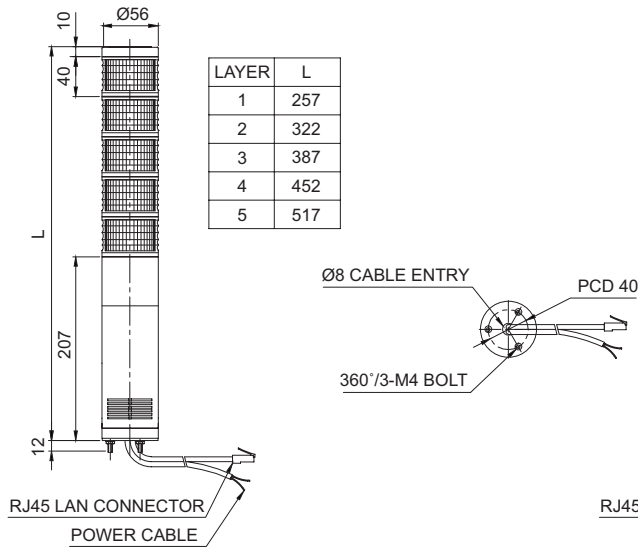

ST56EL-ETN

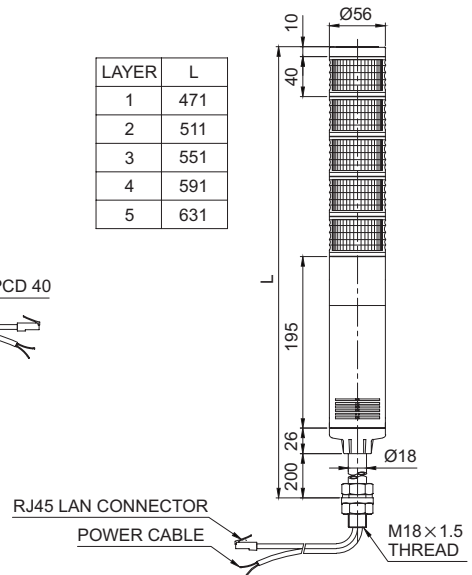

ST80MEL-ETN

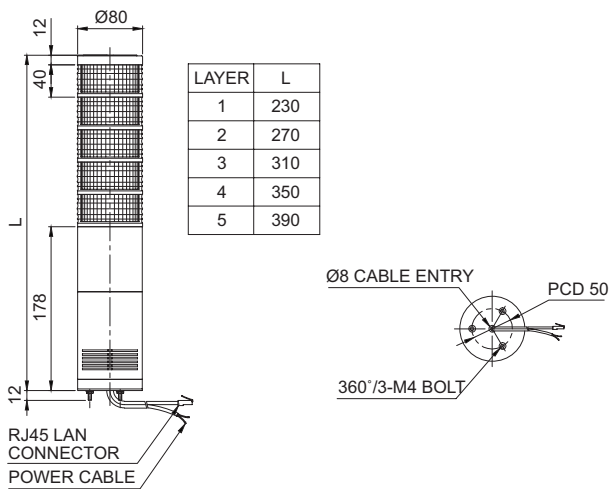

ST80EL-ETN

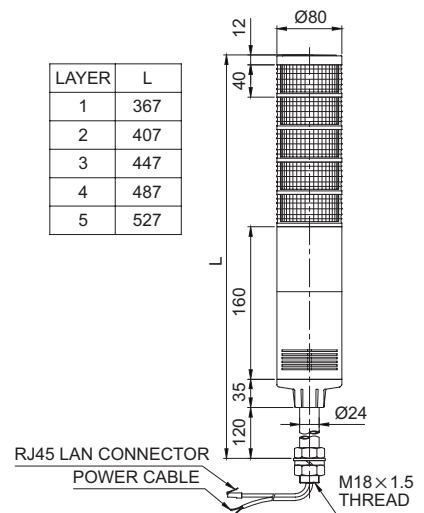

Wiring Instructions

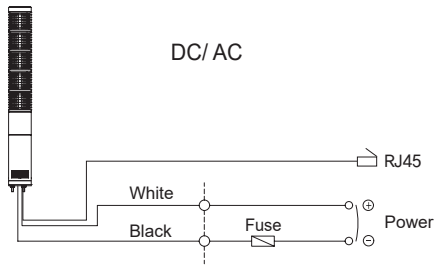

- Connect RJ45 connector that is connected to UTP cable to Ethernet port of a PC or a router.
- External power line - UL1015 AWG18(0.75sq) x 2C 400mm
- For AC type, power cable is equipped with the product.
- UTP Cable : Category 5 cable

Product Installation

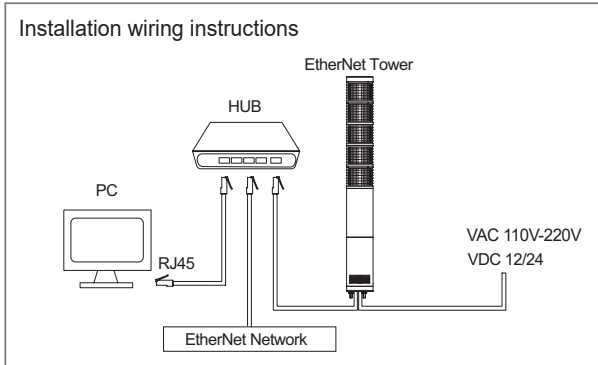

■ Test Ethernet LED Tower Light

1. Please connect LAN cable of the tower light to the router so that the tower light can access Ethernet network by referring left diagram.
2. Please be sure that the power supply shall meet the product specification accordingly.

Applying the Ethernet Device

1. Please activate default PC network only. Please run Windows CMD(Command line) of PC over the same network in order to confirm network information where the Ethernet product will be connected.

Example) Windows 7 : Start(Run)->CMD->ipconfig /all

Windows 10 : Start menu-> Click right mouse button->CMD->ipconfig /all

- Please refer to below network information when the Ethernet product's network environment is configured.

Ethernet adapter Local Area Connection:

```

Connection-specific DNS Suffix . :
IP Address . . . . . : 192.168.10.101
Subnet Mask . . . . . : 255.255.255.0
Default Gateway . . . . . : 192.168.10.1
    
```

2. Because the ETN tower light is connected to a hub with the PC that is same as the picture on the front page, ETN tower light and the PC are now connected with the same network.
3. Please download the product manual, library file and test program from Qlight website(www.qlight.com) or blog.qlight.com

Download

PDF Catalogue

Operating Manual

Test Program

Manual & Library

1.Dev. ETN Program Sample

Program Sample needed when developing (x32bit/x64bit compatibility)

2.How to use

Instructions of how to use the product and library file

4. When you unzip the file, there will be a file with the same name below. The instructions are listed inside the file.

5. When you unzip "ETN TEST PROGRAM.zip" file, following folders are created.

1.ETN Test Program

A program for setting IP before testing the ETN device

2.IP Set Program

A program for setting testing the ETN device

Applying the Ethernet Device

6. Run the "Mac_Setting.exe" program that is inside the IP Set Program Folder .

- ① When the program is running such as the right figure, click the "Mac Find" button in the "Find Mac Address / Select" section
 - MAC Address of the connected device appears when you click the Device List combo box.
 - (If the Mac Addr does not appear, make sure that the connection status or the power supply is functional and then retry.)
- ② Select the MAC Addr of the device you want to change, and then click on the "Read" button.
- ③ Check the information and settings from the "Mac config status"
- ④ Set the value of users network information identified in the previous chapter (subnet mask, gateway) in each text box, and set a different IP_Addr than your PC
Apply the settings by pressing the Write button
 - The port is set to "20000"by default and the port number can be changed if necessary
 - Reconnect After Disconnecting the power from the tower light.

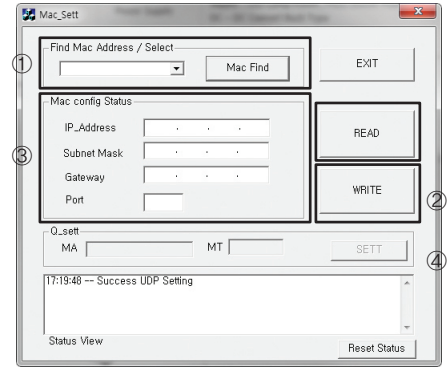

7. ETN Test Program Files folder includes the followings.

 **QLight_Lamptest_TCP.exe**
Test Program

 **QTvc_dll.dll**
Library required for the test program

8. Run the "QLight_Lamptest_TCP" program.

Article	Detailed specification
① Network information setting	- Input port on TCP/PORT and IP address on TCP/IP that set on Ethernet tower lights
② Lamp control	- ON : Click the button Lamp ON - ON/OFF : Click the button Lamp Flash - OFF : Click the button Lamp OFF
③ Sound group selection	- WS : 5 warning sounds(mono) - WP : 5 special warning sounds(mono) - WM(1) : 5 Melodies(mono) - WA(1) : 5 alarms(mono) - WB : Software Buzzer 5 sounds(speaker type) - Buzzer : 5 Buzzer sounds
④ Sound selection	- Select 5 sounds based on model which is fixed on Ordering Specifications

- User can select appropriate sound pattern by referring Ordering Specifications. There're WS, WM, and WA sound patterns and user can choose the option when placing order.

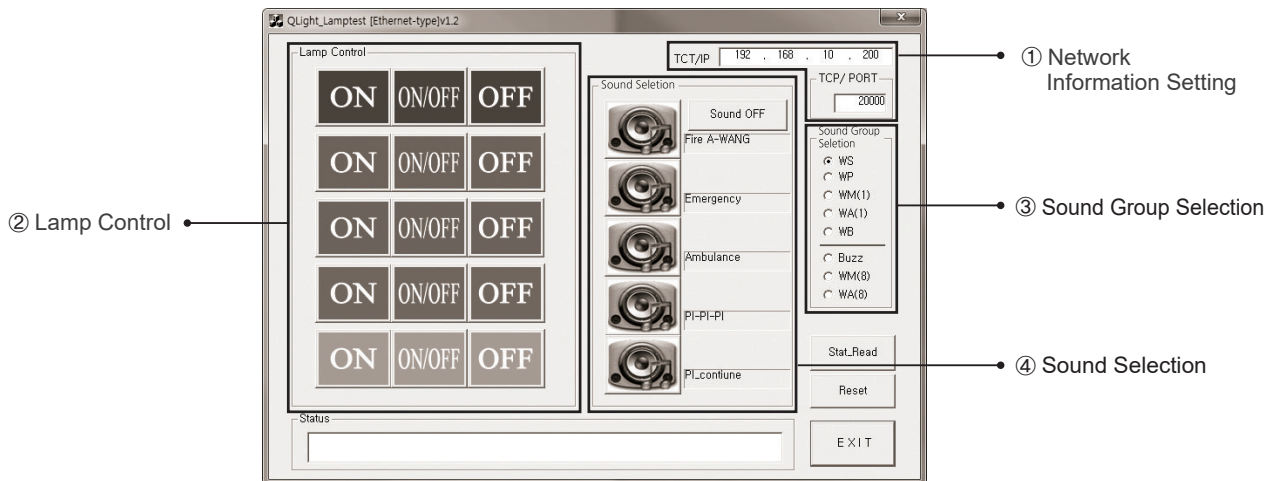

- Fill TCP/IP and TCP/PORT (① Network Information Setting) with IP address and port that has been setted in ethernet tower light.
- When click LAMP ON, correspond lamp turns on.
- When click LAMP OFF, correspond lamp turns off.
- Please choose appropriate sound pattern group by referring ③ Sound Group Selection area.
- You can choose sound pattern by referring ④ Sound Selection.
- Tower lamp plays sound when SOUND button is pressed.
- Tower lamp stops sound when SOUND OFF button is pressed.

Parts Definition

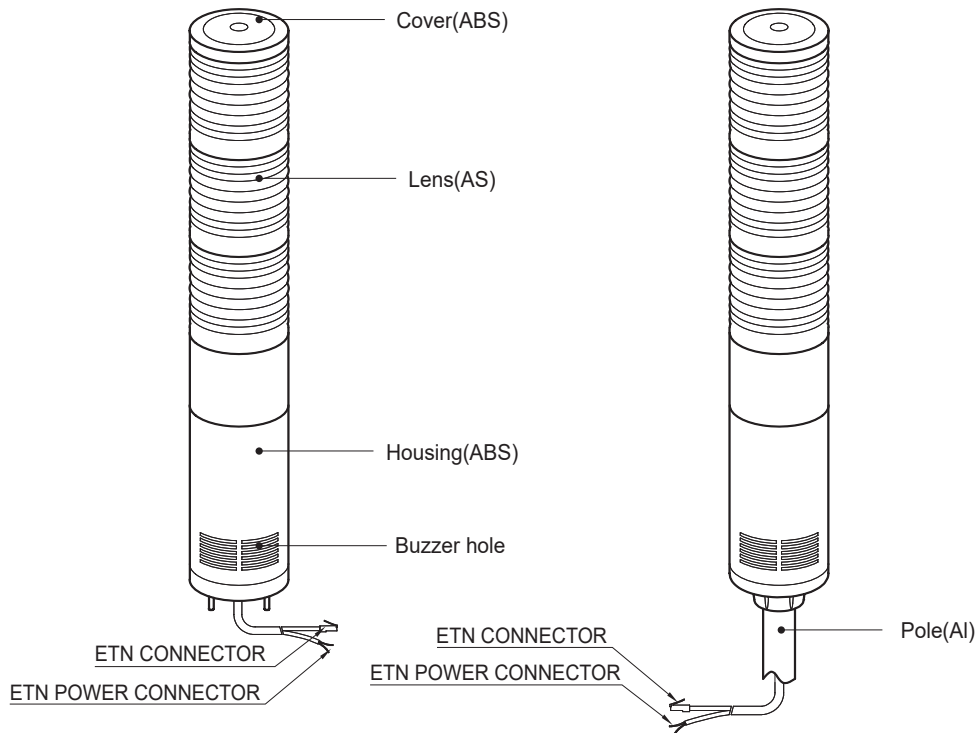

How to Change Lens Kit

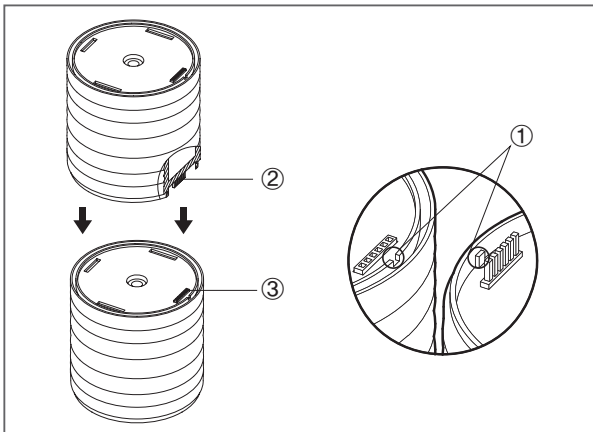

- When rearranging or replacing the lens kits, please be aware of the contact point ① and the connector pin ② marked in the diagram on the left.
- Press down to assemble the lens kits while making sure that connector pin ② and connector ③ aligns correctly.
- Please make sure that the rubber spacer placed on the top of each lens kit is tightly secured to the bottom of the other lens kit.

※ Caution when lens kit

- Lens kits are connected with connector pins each other. Bad connection may be experienced when the connector pins are touched with a foreign substance.
- If the lens kits are not turned on or not flashed after lens kits replacement, please make sure status of lens kit connection.

Mounting Hole Specifications

- ① Machine holes on the mounting surface referring to the diagram below.

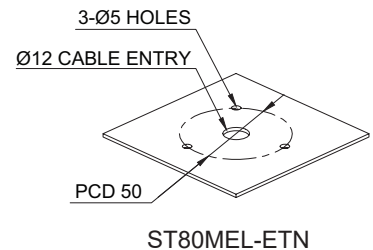
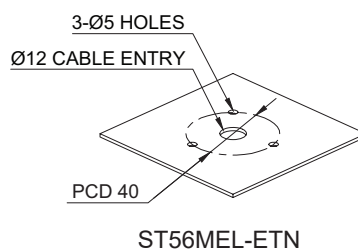
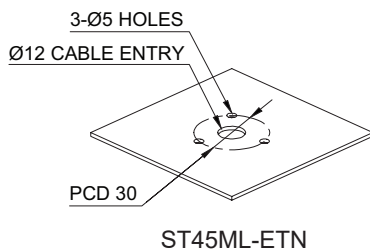

- ② Remove the flange nuts from bolts and place the product through the mounting surface holes.
- ③ Fasten the flange nuts on the opposite side of the mounting surface until the product is tightened securely.

Installation Environment and Protection Rating

- This product is designed for use with protection rating of IP23.
- If the product is installed in locations that subject it to excessive dust or water other than the designated IP protection rating indicated(IP23), it may cause malfunction or damage to the product.
- For further information, please visit our website (www.qlight.com).

Mounting Accessories (Sold Separately)

- Please refer to the dimensions below for installation of mounting brackets

■ ST45ML-ETN/ ST56MEL-ETN/ ST80MEL-ETN - Direct Mounting Type Model

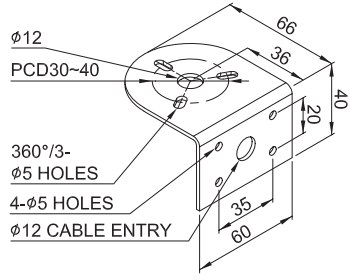
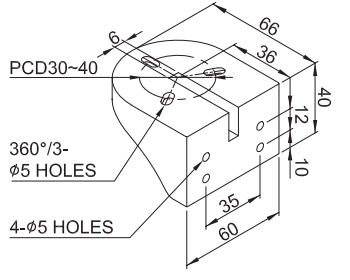
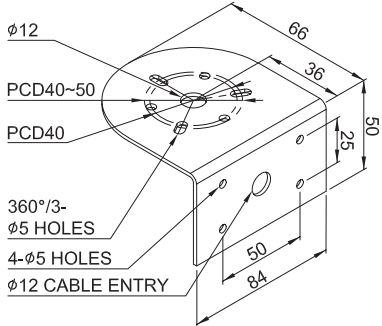
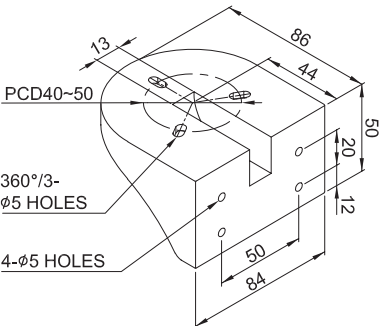
	Dimensions	
ST45ML-ETN ST56MEL-ETN	 <p>TWS45</p>	 <p>TWA45</p>
ST80MEL-ETN	 <p>TWS80</p>	 <p>TWA80</p>

■ ST45L-ETN/ ST56EL-ETN - Pole Mounting Type Model

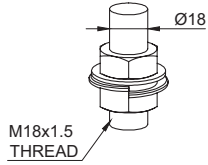
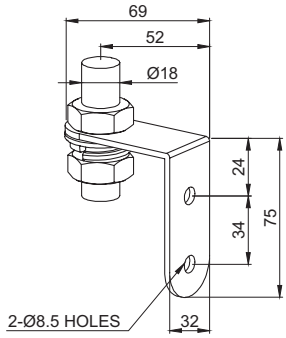
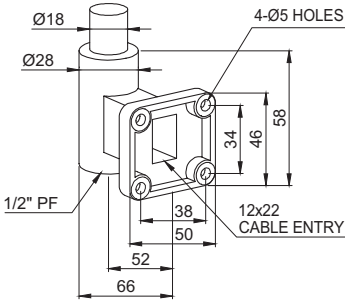
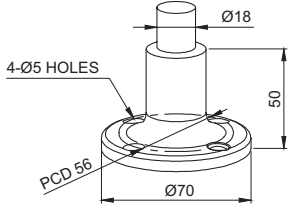
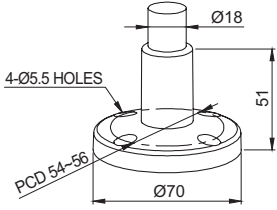
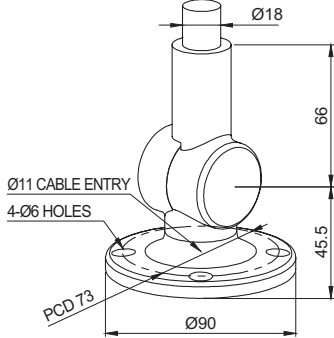
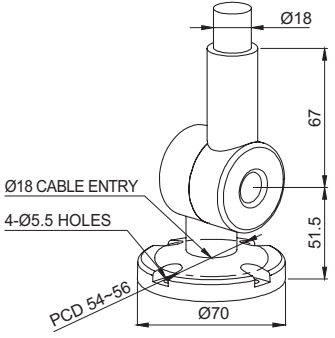
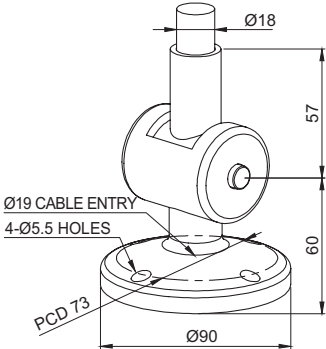
Dimensions	
<p>ST45L-ETN ST56EL-ETN</p>  <p>M18x1.5 THREAD</p> <p style="text-align: center;">18mm SCREW & NUT</p>	 <p style="text-align: center;">LB18</p>
 <p style="text-align: center;">LW18</p>	 <p style="text-align: center;">SZ18</p>
 <p style="text-align: center;">QZ18</p>	 <p style="text-align: center;">SL18</p>
 <p style="text-align: center;">QL18</p>	 <p style="text-align: center;">QLA18</p>

■ ST56EL-ETN - Pole Mounting Type Model

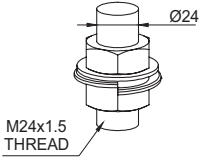
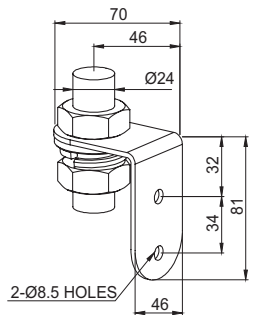
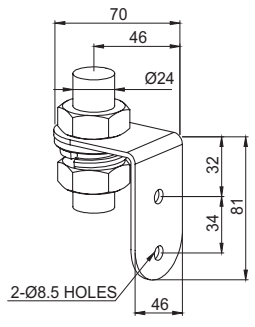
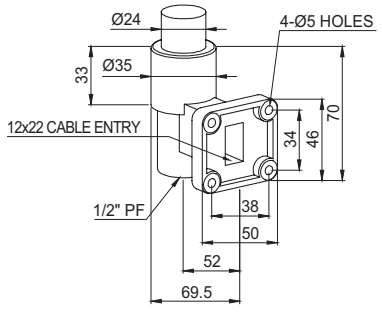
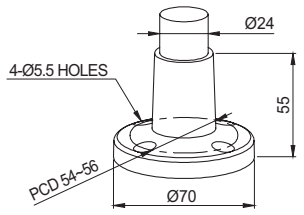
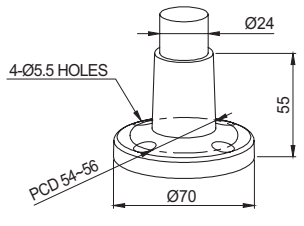
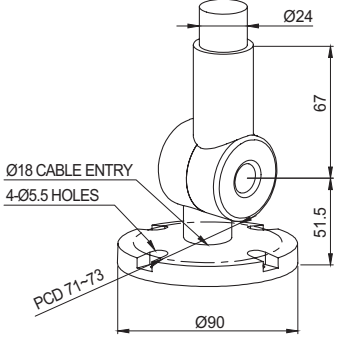
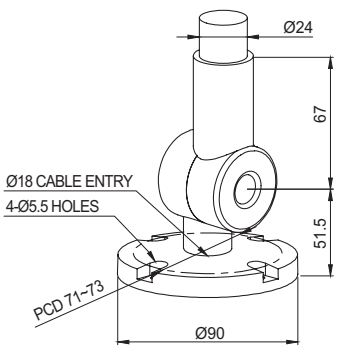
		Dimensions		
ST80EL-ETN	 <p>M24x1.5 THREAD</p> <p>Ø24</p>	<p>24mm SCREW & NUT</p>	 <p>70</p> <p>46</p> <p>Ø24</p> <p>32</p> <p>34</p> <p>81</p> <p>2-Ø8.5 HOLES</p> <p>46</p>	<p>LB24</p>
	 <p>Ø24</p> <p>4-Ø5 HOLES</p> <p>33</p> <p>Ø35</p> <p>12x22 CABLE ENTRY</p> <p>1/2" PF</p> <p>34</p> <p>46</p> <p>70</p> <p>38</p> <p>50</p> <p>52</p> <p>69.5</p>	<p>LW24</p>	 <p>Ø24</p> <p>4-Ø5 HOLES</p> <p>PCD 73</p> <p>Ø90</p> <p>55.5</p>	<p>SZ24</p>
	 <p>Ø24</p> <p>4-Ø5.5 HOLES</p> <p>PCD 54-56</p> <p>Ø70</p> <p>55</p>	<p>QZ24</p>	 <p>Ø24</p> <p>Ø11 CABLE ENTRY</p> <p>4-Ø6 HOLES</p> <p>PCD 73</p> <p>Ø90</p> <p>66</p> <p>45.5</p>	<p>SL24</p>
	 <p>Ø24</p> <p>Ø18 CABLE ENTRY</p> <p>4-Ø5.5 HOLES</p> <p>PCD 71-73</p> <p>Ø90</p> <p>67</p> <p>51.5</p>	<p>QL24</p>	 <p>Ø24</p> <p>Ø19 CABLE ENTRY</p> <p>4-Ø5.5 HOLES</p> <p>PCD 73</p> <p>Ø90</p> <p>57</p> <p>60</p>	<p>QLA24</p>

Technical Certification

- Qlight products are designed to meet strict quality and technical standards. Thus, the Qlight brand is widely recognized for its high quality and technical innovations from leading institutions around the world.



ISO International Organization for Standardization

Qlight quality assurance systems have been certified by ISO by applying the ISO 9001:2008, KS Q ISO 9001:2009 regulation.



IECEX International Explosion Proof Certification (IECEX)

Certified that Qlight's products are being manufactured and manage according to international standards.



ATEX The European Regulatory Framework or Manufacture, Installation and Use of Equipment in Explosive Atmospheres

Qlight's explosion proof products comply with ATEX Directives 94/9/EC.



NEPSI National Supervision and Inspection Center for Explosion Protection and Safety of Instrumentation

Qlight's design and manufacturing system meets the People's Republic of China National explosion proof Standard. (Chinese Standard-GB3836/GB12476)



KCs Explosion Proof Device Safety Certification System

The safety performance of machines and equipment subject to safety certification and Technical capability and production system have been certified safety certification standards.



TIIS Japan Explosion-proof Certification

TIIS is a Japanese explosion proof test and certification system accordance with the Ministry of Health, Labour and Welfare Notice and the explosion proof guidelines for factory electrical equipment. Qlight's explosion proof products have been tested and certified by TIIS.



CCS China Classification Society

Qlight's design and quality assurance system has been certified by the China Classification Society.



RMRS Russian Maritime Register of Shipping

Qlight's design and quality assurance system has been certified from Russian Maritime Register of Shipping.



LR Lloyd's Register

Qlight's design and quality assurance system has been certified from Lloyd's Register.



KR Korean Register of Shipping

Qlight's design and quality assurance system has been certified by the Korean Register of Shipping.



KC Korea Safety Certification

Qlight's products are certified by KC for preventing accident caused by fire.



E-mark Commission Directive Regarding Vehicle Industry

Qlight has obtained EU mark for approved vehicles and vehicle components sold into the EU (EEA : European Economic Area)



ICAO International Civil Aviation Organization

Qlight guarantees our products satisfy the criteria regulated by the International Civil Aviation Organization (ICAO, FAA).



KCC Conformity Assessment of Broadcasting Communication Equipment

Qlight has been certified to protect the electromagnetic environment that causes unwanted electromagnetic waves from the device, communication failure due to other devices or external radio waves, and malfunction of the device.



UL Underwriters Laboratories

Qlight's design and quality assurance system has been certified from UL to ensure the stability of consumption goods and to protect consumers.



CCCF China Certification Center for Security & Protection

Qlight has passed the rigorous examination process of "Passing Fire Protection Products Centering" In order to sell fire-fighting products such as fire alarm equipment to Chinese market.



CCC China Compulsory Certificate

Qlight's has obtained CCC which guarantees safety, protection against fraud, environment, etc.



CE European Commission

Qlight has been certified by the European Commission.



RoHS2 Restriction of Hazardous Substances Directive

Qlight complies with the Restriction of Hazardous Substances Directive by limiting its use of hazardous materials.



For your safety

Specification and dimensions listed in this catalogue subject to change without notice for product quality improvement.
The newest product information is available on our website.(www.qlight.com)
Please read the instruction manual attached to the product carefully before installation and use.

Qlight Co., Ltd. www.qlight.com | trade@qlight.com

Head Office | Suite #1510, STX-V Tower, 128 Gasan digital 1-ro, Geumcheon-gu, Seoul, Korea

Tel. +82-2-2679-6152(Toll free. +82-80-328-2222) Fax. +82-2-2679-6154

Factory | 185-25, Mukbang-ro, Sangdong-myeon, Gimhae-si, Gyeongsangnamdo, Korea Tel. +82-55-328-1111(Toll free. +82-80-328-1111)

Qlight OverSEAs Sales Dept | 704 Nakdong-daero, Sasang-gu, Busan, Korea(Eomgung-Dong) Tel : +82-51-620-4100

Qlight Public Relations & Marketing Team Office | 704 Nakdong-daero, Sasang-gu, Busan, Korea(Eomgung-Dong) Tel. +82-51-245-0017

Qlight USA, Inc. www.qlight.com www.qlightusa.com | sales@qlightusa.com

3003 North First Street, Suite #341, San Jose, CA 95134 USA Tel. +1-408-519-5740 Fax. +1-408-519-5739

SHANGHAI Qlight Electronic Co., Ltd. www.qlight.com www.qlightcn.com | qlightcn@qlight.com

China Factory/ Shanghai Sales Office | #19, Nanda Road, Baoshan Area, Shanghai, China Tel. +86-21-6651-7100 Fax. +86-21-6315-3929

China Factory Site 2 (Qidong) | #33, Haiyan Road, Qidong High-tech Industrial Development Zone, Qidong, Jiangsu Province, China

Tel +86-513-8384-9999 Fax +86-513-8384-9910

Qlightec

Innovation in Alarm & Signal

Product Operation Inquiry / Customer Support +82-51-620-4100

You can expect prompt service if you have exact information such as model name, symptom, telephone number and address.

※ ALL PRODUCT, PRODUCT SPECIFICATIONS AND DATA ARE SUBJECT TO CHANGE WITHOUT NOTICE TO IMPROVE RELIABILITY, FUNCTION OR DESIGN OR OTHERWISE.

Head office : Suite #1510, STX-V Tower, 128 Gasan digital 1-ro, Geumcheon-gu, Seoul, Korea (Postal Code : 08507)

Factory : 185-25, Mukbang-Ro, Sangdong-Myeon, Gimhae-Si, Gyeongsangnam-Do, Korea (Postal Code : 50805)

www.qlight.com

EN - ST45ML-ETN - 2111A