

## JUMBO TYPE IMPACT WRENCHES

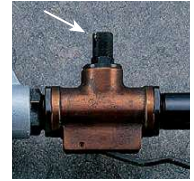

### Built-In Air Regulator

Pull up the spring loaded knob and turn clockwise to lower the power and anticlockwise to increase it, then reset.



BOLT & NUT SETTERS

### SPECIFICATIONS

Recommended Air Pressure : 0.6MPa (85psi)

Model	Capacity (Nominal Bolt Size)		Free Speed (about) min <sup>-1</sup>	Overall Length less Socket (about)		Weight less Socket (about)		From Center to Outside (about)		Sq. Drive Shank		Average Air Consumption		Code
	mm	in		mm	in	kg	lb	mm	in	mm	in	m <sup>3</sup> /min	ft <sup>3</sup> /min	
UW-550	55	2 1/4	3500	525	20 43/64	36.0	79.2	78.0	3 5/64	38.1	1 1/2	2.20	79	11742
UW-75S	75	3	1400	670	26 3/8	56.0	123.0	96.0	3 25/32	44.4	1 3/4	3.20	114	12012
UW-75S (1 1/2)	76	3	1400	670	26 3/8	56.0	123.0	96.0	3 25/32	38.1	1 1/2	3.20	114	12062

Air Hose Size (Inside Diameter) : 19.0 mm (3/4")  
Air Inlet Thread : NPT1"

## STUD BOLT WRENCHES

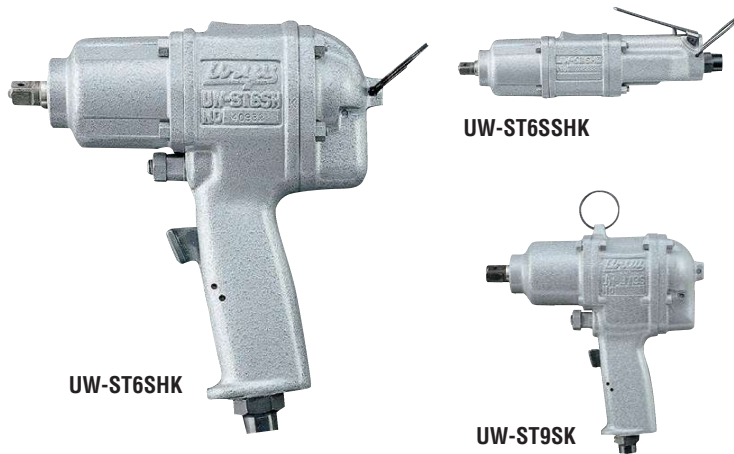

### FEATURES

**Double-Hammer Auto-Reversing for Stud Bolt Driving**

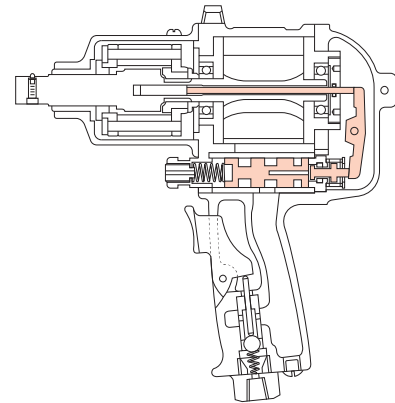

These unique Auto-Reversing tools simply stud-bolt driving (frequent reversing) job considerably for less operator's fatigue & high productivity. Push the tool forward to the work for driving and simply pull it back.

### SPECIFICATIONS

Recommended Air Pressure : 0.6MPa (85psi)

Model	Capacity (Nominal Bolt Size)		Free Speed (about) min <sup>-1</sup>	Overall Length less Socket (about)		Weight less Socket (about)		From Center to Outside (about)		Sq. Drive Shank		Average Air Consumption		Code
	mm	in		mm	in	kg	lb	mm	in	mm	in	m <sup>3</sup> /min	ft <sup>3</sup> /min	
UW-ST6SHK	8	5/16	6500	171	6 47/64	1.70	3.74	28.5	1 1/8	9.5	3/8	0.40	14.0	02132
UW-ST9SK	10	3/8	6300	192	7 9/16	2.35	5.06	33.5	1 5/16	12.7	1/2	0.50	17.6	04432
UW-ST10SHK	10-12	3/8-1/2	6300	194	7 41/64	2.60	5.72	33.5	1 5/16	12.7	1/2	0.50	17.6	04472
UW-ST6SSHK	6-8	1/4-5/16	6500	235	9 1/4	1.35	2.97	28.5	1 1/8	9.5	3/8	0.40	14.0	02172

Air Hose Size (Inside Diameter) : 9.5mm (3/8")  
Air Inlet Thread : NPT1/4"