



# YASKAWA AC Drive Compact Vector Control Drive V1000

200 V CLASS, THREE-PHASE INPUT: 0.1 to 18.5 kW  
200 V CLASS, SINGLE-PHASE INPUT: 0.1 to 3.7 kW  
400 V CLASS, THREE-PHASE INPUT: 0.2 to 18.5 kW



So advanced !

So easy !

So small !

Certified for  
ISO9001 and  
ISO14001



JQA-0422 JQA-EM0498



# Bringing you the world's smallest\* variable speed drive to stand at the top of its class: V1000

Yaskawa has built a reputation for high performance, functionality, quality, and reliability. To make it even easier to optimize your applications, we present the new V1000.

A single drive with so many uses, benefiting your application the more you use it.

## So advanced!

\*: Results from market research on vector drives performed by Yaskawa.

Quick and easy installation, ready to run your application in no time. You'll be amazed how simple it is to use.

# So easy!



# Smallest in the world!

Top performance for its class. Loaded with functions and features in an unbelievably small package!



# C O N T E N T S

|                                |    |
|--------------------------------|----|
| Features                       | 4  |
| Application Benefits           | 8  |
| Software Functions             | 10 |
| Parameter List                 | 12 |
| Basic Instructions             | 16 |
| Product Lineup                 | 18 |
| Model Selection                | 19 |
| Standard Specifications        | 20 |
| Standard Connection Diagram    | 22 |
| Dimensions                     | 24 |
| Fully-Enclosed Design          | 26 |
| Peripheral Devices and Options | 28 |
| Application Notes              | 50 |
| YASKAWA AC Drive Series        | 55 |
| Global Service Network         | 57 |



PUMP



FAN



HVAC

FLUID MACHINE ▶ See page 8.

## APPLICATIONS

COMPACT CONVEYOR ▶ See page 9.



AUTO SHUTTER



PACKAGING



CONVEYOR

Even more eye-opening versatility.

# V1000

## Features

Yaskawa offers solutions customized for your application in an incredibly compact, technologically advanced, environmentally responsible package capable of driving a synchronous motor.

## So advanced!

### Sensorless Control of PM Motors Capability

#### Two drives in one

V1000 runs not only induction motors, but synchronous motors like IPM and SPM motors as well. Get a single drive for all your application needs, and save on spare parts.

Note: See product specifications for information on motor precision.  
The variable torque ratio of synchronous motors is 1 to 10.

#### Conventional models

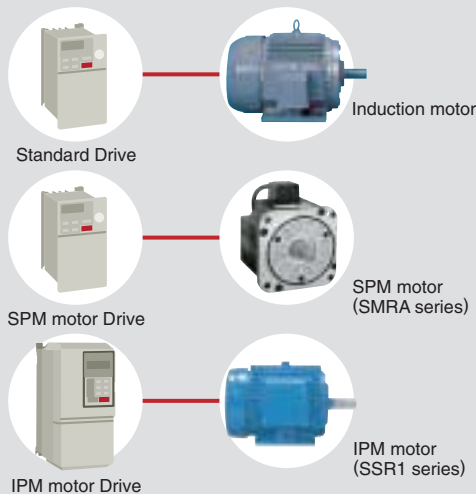

#### V1000

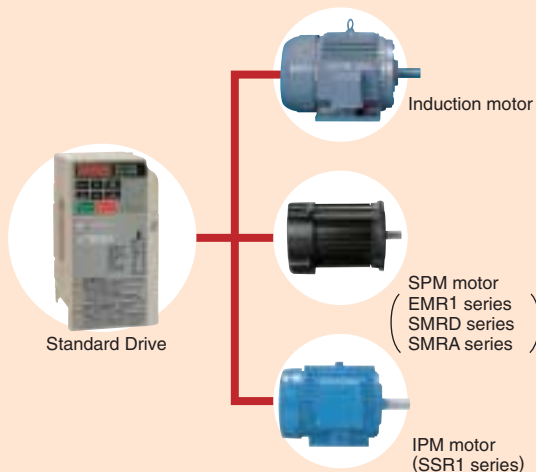

### Top of Its Class

#### Impressive Torque Characteristics

V1000 is the first in its class fully equipped with current vector control. Current Vector control providing a powerful starting torque of 200% at 0.5 Hz\* and precise torque limit operations. The motor Auto-Tuning function saves valuable start up time and assures high performance operation at the highest efficiency.

\*: Using a Yaskawa induction motor under 3.7 kW set for Heavy Duty torque performance.

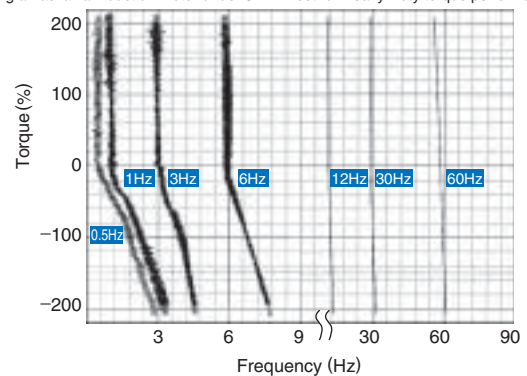

#### Increased braking power during deceleration.

Faster deceleration time with overexcitation braking.\*

\*: Example shown is for a 400 V 3.7 kW drive without braking resistor. Circumstances depends on the motor and load.

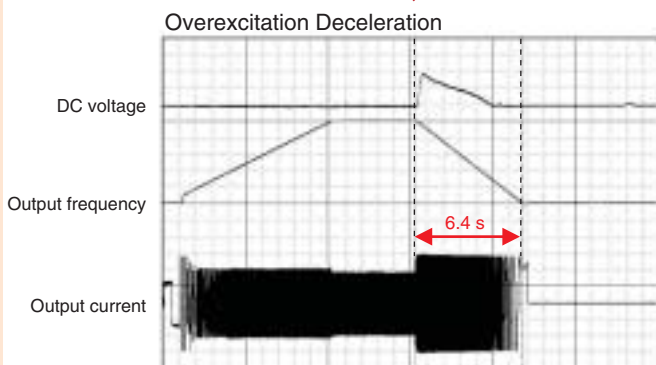
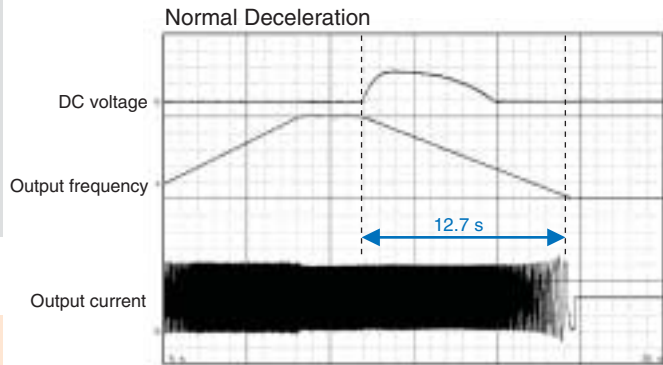

50% faster!

simplest, smallest drive of its class.

### No more trouble from power loss.

V1000 is fully equipped with speed search and KEB Ride-Thru functions for your application needs, whether running an induction motor or permanent magnet motor.

#### ● Speed Search Method

Easily restart the motor without cumbersome speed sensors. Perfect for fan, blowers, and other rotating, fluid-type applications.

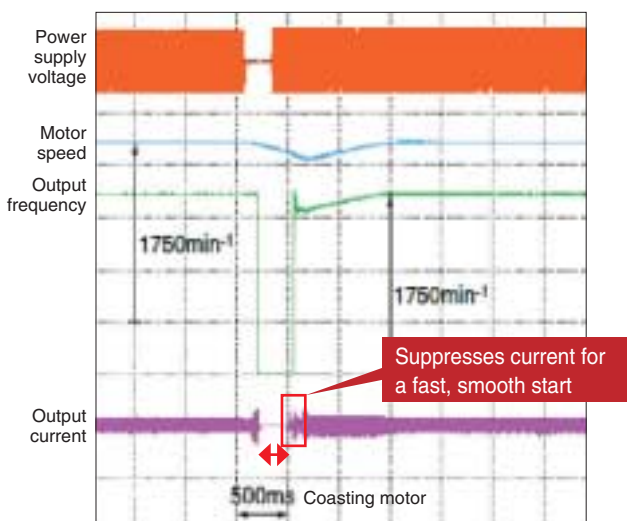

Speed Search performs smooth restart by finding the coasting motors speed.

#### ● KEB Ride-Thru

Drive continues operation by using motor regen. Perfect for HVAC

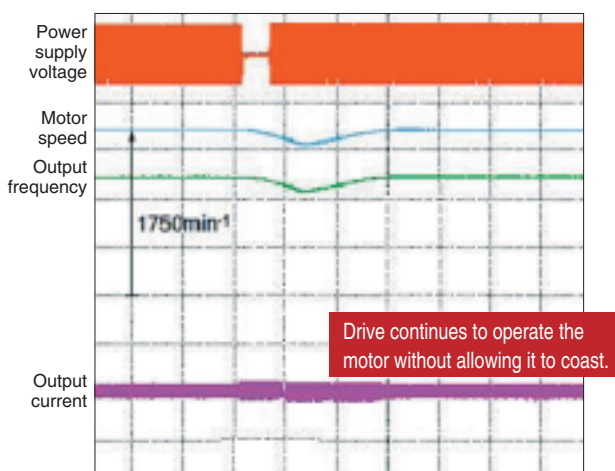

Note: Requires a sensor to detect when power loss occurs. Load conditions may still trip a fault and cause the motor to coast.

### Drive Specialization

#### Software for High-Frequency Output

Yaskawa can offer you a drive with custom software with the specific functions required for your machine.

### Customize the Drive

Optional visual programming software lets you instantly customize V1000 to your application. Let the drive do external device or PLC functions! Easy Drag and Drop functions starting from simple timers up to complex application blocks let you create your very own drive.



### So much variation possible

#### Global Networking

The built in high speed RS-422/485 MEMOBUS and a variety of option units connect V1000 to all popular fieldbus networks. The optional 24 V power supply keeps the drive controller alive under all conditions, providing network communications and monitoring functions even during a main power loss.

|                    |                 |                   |
|--------------------|-----------------|-------------------|
| Open Field Network | MECHATROLINK-II | MECHATROLINK-III* |
|                    | CC-Link         |                   |
|                    | DeviceNet       |                   |
|                    | CompoNet        |                   |
|                    | PROFIBUS-DP     |                   |
|                    | CANopen         |                   |

\*: Available soon

Note: The open field network names mentioned are registered trademarks of their respective companies.

#### Specialized Types

Finless design, and dust-proof models also available.



### Environmentally Friendly

#### Protecting Against Harsh Environments

Various products are available to protect your drive against humidity, dust, oil mist, and vibration. Contact Yaskawa for more information.

#### EU's RoHS Compliance

All V1000 models are fully compliant with the EU's RoHS initiative.

## Features

From setup to maintenance, V1000 makes life easy.

# So easy!

Parameters set automatically—hassle free programming!

### Start up instantly with application presets!

V1000 automatically sets the parameters needed for various applications. Presets for water supply pumps, conveyor systems, exhaust fans, and other applications program the drive instantly for optimized performance—saving enormous hassle setting up for a test run.



| Setting | Application Preset |
|---------|--------------------|
| 00      | General-purpose    |
| 01      | Water Supply Pump  |
| 02      | Conveyor           |
| 03      | Exhaust Fan        |
| 04      | HVAC Fan           |
| 05      | Air Compressor     |
| 06      | Crane (Hoist)      |
| 07      | Crane (Travel)     |

| Parameters are programmed automatically: |                                 |
|--|---------------------------------|
| b1-01                                    | Frequency Reference Selection 1 |
| b1-02                                    | Run Command Selection 1         |
| C1-01                                    | Acceleration Time 1             |
| C1-02                                    | Deceleration Time 1             |
| ⋮  | ⋮                               |

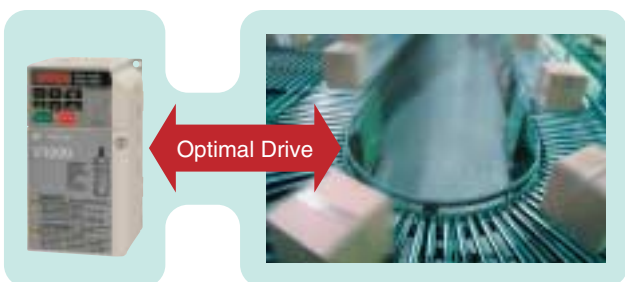
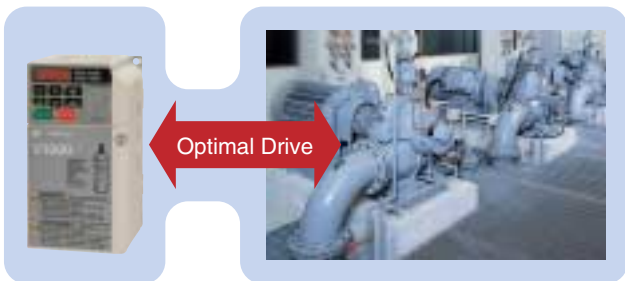

## Breeze-Easy Setup

### Install Multiple Drive Immediately with the USB Copy Unit

Get several drives up and running easily using the USB copy unit. The same copy unit is fully PC compatible.

### Hassle free setting and maintenance straight from a PC

DriveWizard Plus lets you manage the unique settings for all your drives right on your PC.

With DriveWizard's preset operation sequences, built-in oscilloscope function, fine tuning the drive and maintenance checks have never been easier.



- **Drive Replacement Function**  
Saves valuable time during drive set up when replacing or upgrading drives.



- **Sequence Operation**  
View and edit drive parameters.



- **Oscilloscope Function**  
Displays operation status and drive performance in real time.

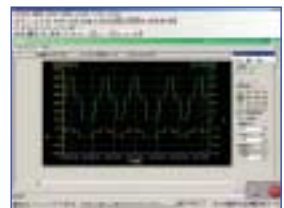

## Safety Standard Compliance TÜV approved

V1000 is the first drive in its class to come standard with safety input features compliant with ISO13849-1 Cat.3 PLd, IEC/EN61508 SIL2.

Through compliance with EN60204-1 (stop category 0), V1000 reduces the number of peripheral devices needed to satisfy safety regulations.

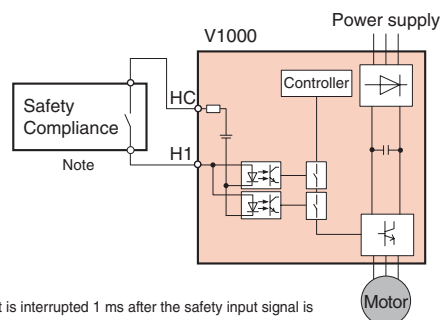

Note: Output is interrupted 1 ms after the safety input signal is triggered.  
Make sure safety input wiring does not exceed 30 m.

Application Example: Safety Compliance

## Hassle-Free Maintenance

### Less Downtime

The first-ever pluggable terminal board with a Parameter Back-Up function lets you replace a drive instantly in the event of failure. No need to re-program the replacement drive—an amazingly convenient time saver!

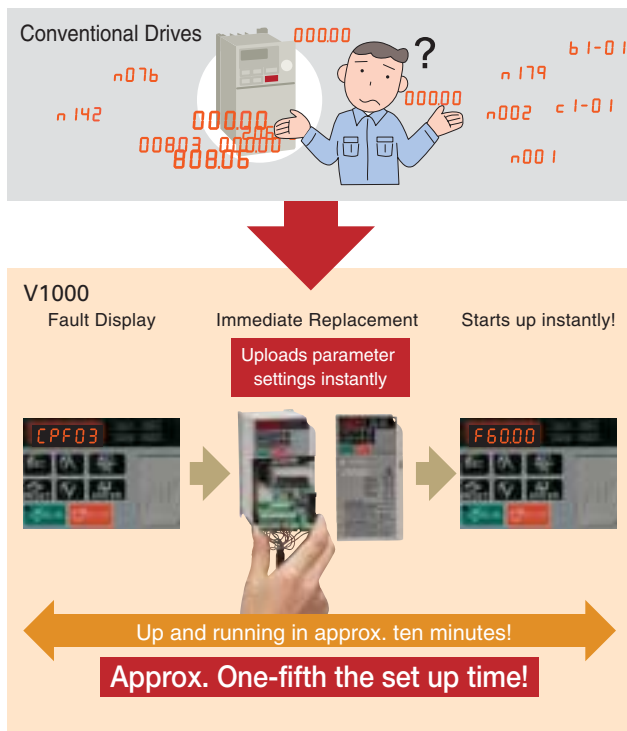

### Exceptional Performance Life

Cooling fan and capacitors have an expected performance life of ten years. In addition, Maintenance Monitors keep track of part wear.

Note: Assumes operation conditions of 40°C, 80% rated load, and 24 hour continuous performance. Performance life may vary with operation conditions.

### Simple Wiring

A pluggable terminal block option is available. Screwless terminals do away with time consuming wiring and periodic maintenance to check wire connections, which in turn makes the drive more reliable. Contact Yaskawa for inquiries.

### Wide Array of Monitors

Monitor functions like output frequency, output current, I/O status and watt hour counter give a clear picture of the drive operation status and helps to keep track of the energy consumption.

### Verify Menu

The Verify Menu lists all setting that have been changed from their original default values. This includes parameters changed by Auto-Tuning, Application Presets, and those edited by the technician. This list makes it easy to reference changes to drive setup.

## The world's smallest!

### The perfect space-saving design

#### World's Smallest Class

Yaskawa has applied the most advanced thermal simulation technology and top reliability to create the world's smallest compact drive. V1000 reduces the space required up to 70% when compared to our earlier models.

● Compare the size difference of a 200 V 5.5 kW drive with V1000 rated for Normal Duty operation:

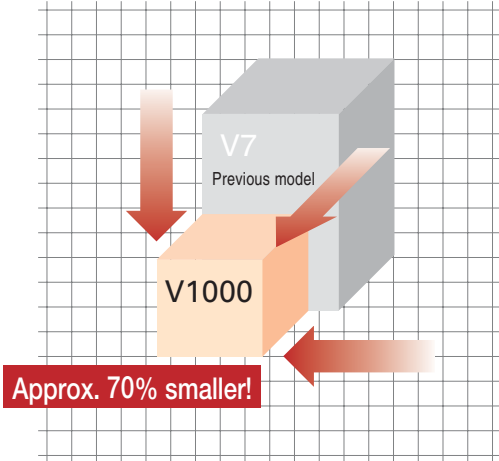

### Side-by-Side

V1000 allows for a truly compact installation, requiring minimal space between units even in a tight enclosure.

Note: Current derating must be considered.

● Example: Side-by-Side installation of 200 V 0.75 kW units

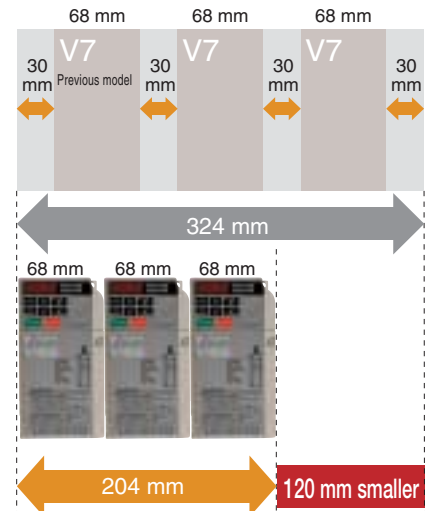

Note: If the last drive in a series is installed next to a wall, a 30 mm gap is required.

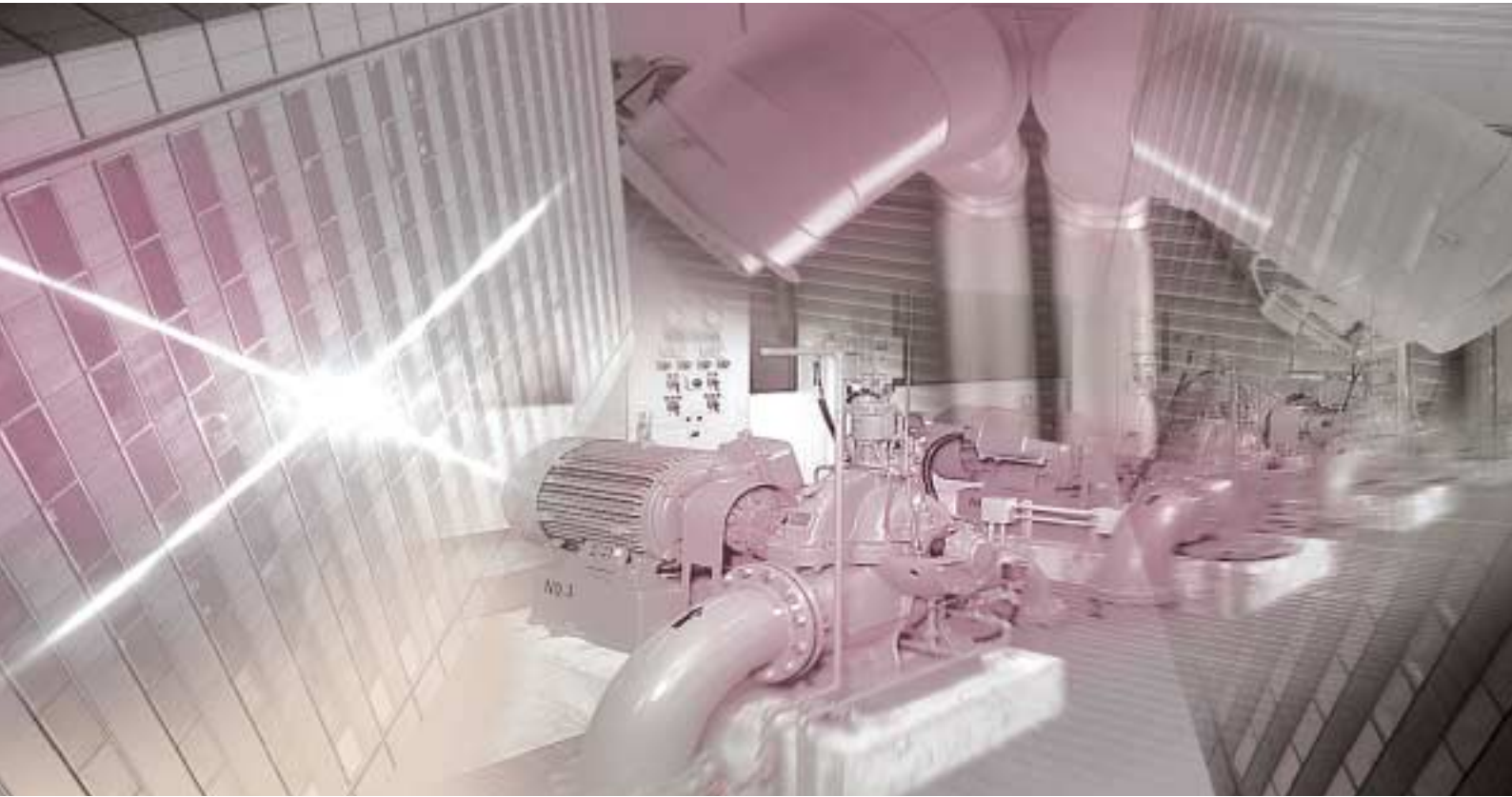

## Fluid Applications

Advantages

- 1 Selecting “Fan” or “Pump” presets automatically programs V1000 for optimal performance.
- 2 Compact design saves installation space. Use a permanent magnet motor to shrink the installation even further while conserving impressive amounts of energy.

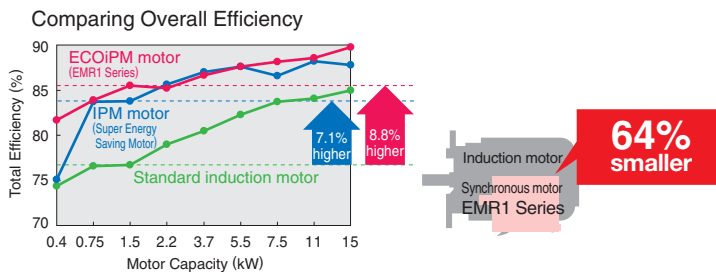

- 3 Pulse output provided to keep track of kilowatt hours-- no power meter needed. (Cannot legally be used as proof of power consumption.)
- 4 Speed Search prevents loss from down time by keeping the application running smoothly through a power loss.
- 5 An optional 24 V power supply lets you monitor drive performance from a PLC even when the power goes out.
- 6 Replace drives immediately and easily thanks to a pluggable terminal board with a built-in Parameter Back-Up function.

Functions

|                                      |                                       |                                       |
|--------------------------------------|---------------------------------------|---------------------------------------|
| <b>NEW</b><br>Application Presets    | <b>NEW</b><br>Watt Hour Pulse Monitor | Undertorque Detection                 |
| <b>NEW</b><br>Overexcitation Braking | Energy Saving                         | Momentary Power Loss Ride-Thru        |
| Speed Search                         | <b>NEW</b><br>Drive WorksEZ           | Stall Prevention                      |
| Multi-Step Speed                     | <b>NEW</b><br>PTC Input               | <b>NEW</b><br>Overvoltage Suppression |
| <b>NEW</b><br>LOCAL/REMOTE           | PID Control                           | Reference Loss Operation              |
| <b>NEW</b><br>IM/PM Control          | Overtorque Detection                  | Fault Restart                         |

**NEW** Functions New software functions for V1000

Applications



Fan



Pump



HVAC





## Conveyor, Transport, and Civil Applications

### Advantages

- 1** Selecting the “Conveyor” preset automatically programs V1000 for optimal performance.
- 2** Safety input functions standard. Easily complies with various safety regulations.
- 3** Overexcitation braking provides more powerful braking capabilities.
- 4** Easily customize the drive through visual programming with DriveWorksEZ.
- 5** With a variety of communication protocols options available, V1000 can be networked instantly. A separate 24 V power supply is also available, allowing the technician to monitor drive performance from a PLC even when the power goes out.
- 6** IP66 and NEMA 4 Type 1 models are available. Provides water-proof and dust-proof protection and separate installation.

### Functions

|                                      |                             |                              |
|--------------------------------------|-----------------------------|------------------------------|
| <b>NEW</b><br>Application Presets    | <b>NEW</b><br>LOCAL/REMOTE  | Pulse Train Output           |
| <b>NEW</b><br>Overexcitation Braking | <b>NEW</b><br>IM/PM Control | <b>NEW</b><br>Torque Limit   |
| S-Curve Characteristics              | <b>NEW</b><br>Online Tuning | <b>NEW</b><br>Current Vector |
| Multi-Step Speed                     | <b>NEW</b><br>Drive WorksEZ | Stall Prevention             |
| Up/Down                              | Pulse Train Input           | Fault Restart                |

**NEW** New Functions      New software functions for V1000

### Applications





# Software Functions

## Loaded with software functions just right for your application.

Note: Major functions listed below.

**New Functions** New V1000 software not available for the V7.

**NEW**  
Application Presets

**No need to struggle with difficult parameters and complex calculations.** Parameters are set instantly simply by selecting the appropriate Application Preset.

### Functions at Start and Stop

**NEW**  
Optimal Deceleration

**Optimal deceleration without needing to set the deceleration time.** Drive slows the application smoothly controlling DC bus voltage.

**NEW**  
Overexcitation Braking

**Perfect for applications with high load inertia that rarely need to be stopped.** Stop quickly—50% faster without the use of a braking resistor. *Note: Stopping times may vary based on motor characteristics.*

DC Injection Braking at Start

**Halt a coasting motor and start it back up again.** When the direction of a coasting motor is unknown, the drive automatically performs DC Injection to bring the motor to a halt and then start it back up again.

Speed Search

**Start a coasting motor.** Automatically brings a coasting motor back to the target frequency without the need for extra speed sensors.

Dwell Function

**Accelerate and decelerate smoothly with large inertia loads.** Drive prevents speed loss by holding the output frequency at a constant level during acceleration and deceleration.

Accel/Decel Time Switch

**Switch easily between accel/decel times.** Switch acceleration and deceleration rates when running two motors from the same drive, or change accel/decel times when operating at high speed.

S-Curve Characteristics

**Prevent sudden shock when starting and stopping the application.** Drive lets the user fine-tune the S-curve characteristics, allowing for smooth acceleration and deceleration.

### Reference Functions

Frequency Reference Upper/Lower Limits

**Limit motor speed.** Set speed limits and eliminate the need for extra peripheral devices and extraneous hardware.

Multi-Step Speed

**Easily program a speed sequence with multiple steps.** Set up to 17 separate speeds to create a speed sequence for the application. The drive can easily be connected to a PLC and allow for a simple positioning with limit switches.

Frequency Jump

**Skip over troublesome resonant frequencies.** Drive can be programmed to avoid machine resonance problems by avoiding constant speed operation at certain speeds.

Frequency Reference Hold

**Improved operability.** Momentarily hold the operating frequency during acceleration or deceleration as the load is lowered or raised.

Up/Down

**Improved operability.** Raise or lower the frequency reference using a remote switch.

**NEW**  
LOCAL/REMOTE

**Switch between remote operating locations.** Easily switch between controlling the drive directly with the keypad or from a control panel at some remote location.

### Functions for Top Performance

**NEW**  
IM/PM Control

**Run both IM and PM motors with a single drive.** The most advanced motor drive technology can run both IM and PM motors, allowing for even greater energy savings and a more compact setup.

**NEW**  
Watt-Hour Pulse Monitor

**No extra watt hour meter needed.** A pulse output lets the user monitor power consumption. (Cannot legally be used as proof of power consumption)

Energy Saving

**Automatically runs at top efficiency.** The drive supplies voltage to the motor relative to the speed and load so that the application is for operating at the most efficient level.

**NEW**  
Online Tuning

**Enables high-precision operation.** Automatically adjusts resistance between motor conductors during operation, thus improving speed accuracy when there are motor temperature fluctuations. This function is active only for Open Loop Vector Control.

**NEW**  
Current Vector

**Achieve high levels of performance.** The drive comes with current vector control capabilities for high performance applications.

NEW

**Drive WorksEZ****Customize the perfect drive to fit your needs.**

Upper controller circuitry and drive I/O terminals can be programmed so that extra hardware is no longer needed. Drag-and-drop visual programming makes customization a breeze.

NEW

**Timer Function****No need for extra hardware.**

Control timing by opening and closing the output signal relative to the input signal.

NEW

**PTC Input****Thermal protection provided by a PTC located in the motor windings.**

Protect the motor from over heat by directly connecting the PTC to the drive.

**PID Control****Automatic PID control.**

The internal PID controller fine-adjusts the output frequency for precise control of pressure, flow or other process parameters.

NEW

**Motor 2 Switch****One drive runs two motors.**

Use a single drive to operate two different motors. (Only one PM motor may be used)

**Pulse Train Input****Improved operability.**

Use the Pulse Train Input to control not only the frequency reference, but also PID feedback and PID input.

**Pulse Train Output****Improved monitor functions.**

Pulse output lets the user observe everything from the frequency reference and output frequency to motor speed, softstart output frequency, PID feedback, and PID input.

**Frequency Detection****Use frequency detection for brake control.**

The drive can output a signal when the output frequency exceeds a specified level.

**Overtorque Detection****Keep the application running while protecting connected machinery.**

Overtorque detection senses motor torque and notifies the user immediately when a filter clogs or the machine is blocked by mechanical problems.

**Undertorque Detection****Better reliability: Keep the application running while protecting the load.**

Fault detection senses any drop in motor torque due to broken belts or worn transmission.

NEW

**Torque Limit****Better reliability: Keep the application running while protecting the load.**

V1000 helps protect your application by restricting the amount of torque the motor can create.

**Protective Functions****Momentary Power Loss Ride-Thru****Keep running even during a momentary loss in power.**

V1000 automatically restarts the motor and keeps the application going in the event of a power loss.

NEW

**KEB Function****Decelerate to stop when the power goes out.**

V1000 uses regenerative energy from the motor to bring the application to a stop, rather than simply letting it coast.

**Stall Prevention****Better reliability: Keep the application running while protecting the load.**

Keeps the machine running by preventing motor stall caused by motor overload or rapid speed changes.

NEW

**Overvoltage Suppression****Avoid overvoltage trip.**

Effective for punching presses and crank shafts where repetitive motion creates large amounts of regenerative energy. The drive increases or decreases the frequency in correspondence with regen levels to prevent overvoltage from occurring.

**Reference Loss Operation****Better reliability for continuous operation.**

The drive can keep running at the most recent frequency reference it was given in the event that the upper controller should fail. An absolute must for HVAC systems.

**Fault Restart****Keep running when a fault occurs.**

V1000 has full self-diagnostic features and can restart the application in the event of a fault. Up to 10 restarts possible.







# Parameter List (continued)

| Function                                   | No.                           | Name  | Range   | Def <sup>#1</sup> | Control Mode |     |    |
|--|-------------------------------|---|---|-------------------|--------------|-----|----|
|  |                               |   |   |                   | V/f          | OLV | PM |
| Serial Communications Option Card Settings | F6-55                         | DeviceNet Baud Rate from Network                            | 0 to 2 (read only)  | —                 | ○            | ○   | ○  |
|  | F6-56                         | DeviceNet / CompoNet Speed Scaling Factor                   | -15 to 15   | 0                 | ○            | ○   | ○  |
|  | F6-57                         | DeviceNet / CompoNet Current Scaling Factor                 | -15 to 15   | 0                 | ○            | ○   | ○  |
|  | F6-58                         | DeviceNet / CompoNet Torque Scaling Factor                  | -15 to 15   | 0                 | ○            | ○   | ○  |
|  | F6-59                         | DeviceNet / CompoNet Power Scaling Factor                   | -15 to 15   | 0                 | ○            | ○   | ○  |
|  | F6-60                         | DeviceNet / CompoNet Voltage Scaling Factor                 | -15 to 15   | 0                 | ○            | ○   | ○  |
|  | F6-61                         | DeviceNet / CompoNet Time Scaling Factor                    | -15 to 15   | 0                 | ○            | ○   | ○  |
|  | F6-62                         | DeviceNet Heartbeat Interval                                | 0 to 10   | 0                 | ○            | ○   | ○  |
|  | F6-63                         | DeviceNet MAC ID from Network                               | 0 to 63 (read only)   | —                 | ○            | ○   | ○  |
|  | Multi-Function Digital Inputs | H1-01   | Multi-Function Digital Input Terminal S1 Function Selection | 1 to 9F           | 40           | ○   | ○  |
| H1-02                                      |                               | Multi-Function Digital Input Terminal S2 Function Selection | 41  |                   | ○            | ○   | ○  |
| H1-03                                      |                               | Multi-Function Digital Input Terminal S3 Function Selection | 24  |                   | ○            | ○   | ○  |
| H1-04                                      |                               | Multi-Function Digital Input Terminal S4 Function Selection | 14  |                   | ○            | ○   | ○  |
| H1-05                                      |                               | Multi-Function Digital Input Terminal S5 Function Selection | 3(0)  |                   | ○            | ○   | ○  |
| H1-06                                      |                               | Multi-Function Digital Input Terminal S6 Function Selection | 4(3)  |                   | ○            | ○   | ○  |
| H1-07                                      |                               | Multi-Function Digital Input Terminal S7 Function Selection | 6(4)  |                   | ○            | ○   | ○  |
| Multi-Function Digital Outputs             |                               | H2-01   | Terminal MA, MB and MC Function Selection (relay)           |                   | 0 to 192     | E   | ○  |
|  | H2-02                         | Terminal P1 Function Selection (open-collector)             | 0   | ○                 |              | ○   | ○  |
|  | H2-03                         | Terminal P2 Function Selection (open-collector)             | 2   | ○                 |              | ○   | ○  |
|  | H2-06                         | Watt Hour Output Unit Selection                             | 0 to 4  | 0                 |              | ○   | ○  |
| Analog Inputs                              | H3-01                         | Terminal A1 Signal Level Selection                          | 0,1   | 0                 | ○            | ○   | ○  |
|  | H3-02                         | Terminal A1 Function Selection                              | 0 to 31   | 0                 | ○            | ○   | ○  |
|  | H3-03                         | Terminal A1 Gain Setting                                    | -999.9 to 999.9   | 100.0%            | ○            | ○   | ○  |
|  | H3-04                         | Terminal A1 Bias Setting                                    | -999.9 to 999.9   | 0.0%              | ○            | ○   | ○  |
|  | H3-09                         | Terminal A2 Signal Level Selection                          | 0 to 3  | 2                 | ○            | ○   | ○  |
|  | H3-10                         | Terminal A2 Function Selection                              | 0 to 31   | 0                 | ○            | ○   | ○  |
|  | H3-11                         | Terminal A2 Gain Setting                                    | -999.9 to 1000.0  | 100.0%            | ○            | ○   | ○  |
|  | H3-12                         | Terminal A2 Input Bias                                      | -999.9 to 999.9   | 0.0%              | ○            | ○   | ○  |
|  | H3-13                         | Analog Input Filter Time Constant                           | 0.00 to 2.00  | 0.03 s            | ○            | ○   | ○  |
|  | H3-14                         | Analog Input Terminal Enable Selection                      | 1,2,7   | 7                 | ○            | ○   | ○  |
| Multi-Function Analog Outputs              | H4-01                         | Multi-Function Analog Output Terminal AM                    | 000 to 999  | 102               | ○            | ○   | ○  |
|  | H4-02                         | Multi-Function Analog Output Terminal AM Gain               | -999.9 to 999.9   | 100.0%            | S            | S   | S  |
|  | H4-03                         | Multi-Function Analog Output Terminal AM Bias               | -999.9 to 999.9   | 0.0%              | ○            | ○   | ○  |
| MEMOBUS/Modbus Communications              | H5-01                         | Drive Slave Address   | 0 to 20 H   | 1F                | ○            | ○   | ○  |
|  | H5-02                         | Communication Speed Selection                               | 0 to 8  | 3                 | ○            | ○   | ○  |
|  | H5-03                         | Communication Parity Selection                              | 0 to 2  | 0                 | ○            | ○   | ○  |
|  | H5-04                         | Stopping Method After Communication Error                   | 0 to 3  | 3                 | ○            | ○   | ○  |
|  | H5-05                         | Communication Fault Detection Selection                     | 0,1   | 1                 | ○            | ○   | ○  |
|  | H5-06                         | Drive Transmit Wait Time                                    | 5 to 65   | 5 ms              | ○            | ○   | ○  |
|  | H5-07                         | RTS Control Selection                                       | 0,1   | 1                 | ○            | ○   | ○  |
|  | H5-09                         | CE Detection Time   | 0.0 to 10.0   | 2.0 s             | ○            | ○   | ○  |
|  | H5-10                         | Unit Selection for MEMOBUS/Modbus Register 0025H            | 0,1   | 0                 | ○            | ○   | ○  |
|  | H5-11                         | Communications ENTER Function Selection                     | 0,1   | 1                 | ○            | ○   | ○  |
|  | H5-12                         | Run Command Method Selection                                | 0,1   | 0                 | ○            | ○   | ○  |
|  | Pulse Train Input/Output      | H6-01   | Pulse Train Input Terminal RP Function Selection            | 0 to 3            | 0            | ○   | ○  |
| H6-02                                      |                               | Pulse Train Input Scaling                                   | 100 to 32000  | 1440 Hz           | ○            | ○   | ○  |
| H6-03                                      |                               | Pulse Train Input Gain                                      | 0.0 to 1000.0   | 100.0%            | ○            | ○   | ○  |
| H6-04                                      |                               | Pulse Train Input Bias                                      | -100.0 to +100.0  | 0.0%              | ○            | ○   | ○  |
| H6-05                                      |                               | Pulse Train Input Filter Time                               | 0.00 to 2.00  | 0.10 s            | ○            | ○   | ○  |

| Function                   | No.                 | Name  | Range                            | Def <sup>#1</sup>      | Control Mode |     |    |
|----------------------------|---------------------|---|----------------------------------|------------------------|--------------|-----|----|
|                            |                     |   |                                  |                        | V/f          | OLV | PM |
| Pulse Train Input/Output   | H6-06               | Pulse Train Monitor Terminal MP Selection                           | 000,031,101,102, 105,116,501,502 | 102                    | ○            | ○   | ○  |
|                            | H6-07               | Pulse Train Monitor Scaling   | 0 to 32000                       | 1440 Hz                | ○            | ○   | ○  |
|                            | H6-08               | Pulse Train Input Minimum Frequency                                 | 0.1 to 1000.0                    | 0.5 Hz                 | ○            | ○   | ○  |
|                            | L1-01               | Motor Overload Protection Selection                                 | 0 to 4,6                         | 1                      | S            | S   | S  |
|                            | L1-02               | Motor Overload Protection Time                                      | 0.1 to 5.0                       | 1.0 min                | ○            | ○   | ○  |
|                            | L1-03               | Motor Overheat Alarm Operation Selection (PTC input)                | 0 to 3                           | 3                      | ○            | ○   | ○  |
|                            | L1-04               | Motor Overheat Fault Operation Selection (PTC input)                | 0 to 2                           | 1                      | ○            | ○   | ○  |
|                            | L1-05               | Motor Temperature Input Filter Time (PTC input)                     | 0.00 to 10.00                    | 0.20 s                 | ○            | ○   | ○  |
|                            | L1-13               | Continuous Electrothermal Operation Selection                       | 0,1                              | 1                      | ○            | ○   | ○  |
|                            | L1-22 <sup>*2</sup> | Leakage Current Filter 1  | 0.0 to 60.0                      | 20.0                   | ○            | ○   | ○  |
| Motor Protection Functions | L1-23 <sup>*2</sup> | Leakage Current Filter 2  | 0.0 to 60.0                      | 1.0                    | ○            | ○   | ○  |
|                            | L2-01               | Momentary Power Loss Operation Selection                            | 0 to 2                           | 0                      | ○            | ○   | ○  |
|                            | L2-02               | Momentary Power Loss Ride-Thru Time                                 | 0.0 to 25.5                      |                        | ○            | ○   | ○  |
|                            | L2-03               | Momentary Power Loss Minimum Baseblock Time                         | 0.1 to 5.0                       | dep. on drive capacity | ○            | ○   | ○  |
|                            | L2-04               | Momentary Power Loss Voltage Recovery Ramp Time                     | 0.0 to 5.0                       |                        | ○            | ○   | ○  |
|                            | L2-05 <sup>*3</sup> | Undervoltage Detection Level (Uv)                                   | 150 to 210                       |                        | ○            | ○   | ○  |
|                            | L2-06               | KEB Deceleration Time   | 0.0 to 200.0                     | 0.0 s                  | ○            | ○   | ○  |
|                            | L2-07               | KEB Acceleration Time   | 0.0 to 25.5                      | 0.0 s                  | ○            | ○   | ○  |
|                            | L2-08               | KEB Start Output Frequency Reduction                                | 0 to 300                         | 100%                   | ○            | ○   | ○  |
|                            | L2-11 <sup>*3</sup> | Desired DC Bus Voltage during KEB                                   | 150 to 400                       | E1-01 × 1.22 (V)       | ○            | ○   | ○  |
| Momentary Power Loss       | L3-01               | Stall Prevention Selection during Acceleration                      | 0 to 2                           | 1                      | ○            | ○   | ○  |
|                            | L3-02               | Stall Prevention Level during Acceleration                          | 0 to 150                         | dep. on drive capacity | ○            | ○   | ○  |
|                            | L3-03               | Stall Prevention Limit during Acceleration                          | 0 to 100                         | 50%                    | ○            | ○   | ○  |
|                            | L3-04               | Stall Prevention Selection during Deceleration                      | 0 to 4,7                         | 1                      | S            | S   | S  |
|                            | L3-05               | Stall Prevention Selection during Run                               | 0 to 2                           | 1                      | ○            | ×   | ○  |
|                            | L3-06               | Stall Prevention Level during Run                                   | 30 to 150                        | dep. on drive capacity | ○            | ×   | ○  |
|                            | L3-11               | ov Suppression Function Selection                                   | 0,1                              | 0                      | ○            | ○   | ○  |
|                            | L3-17 <sup>*3</sup> | Overvoltage Suppression and Stall Prevention Desired DC Bus Voltage | 150 to 400                       | 370 V                  | ○            | ○   | ○  |
|                            | L3-20               | Main Power Circuit Voltage Adjustment Gain                          | 0.00 to 5.00                     | 1.00                   | ○            | ○   | ○  |
|                            | L3-21               | Accel/Decel Rate Calculation Gain                                   | 0.00 to 200.00                   | 1.00                   | ○            | ○   | ○  |
| Stall Prevention Functions | L3-22               | Deceleration Time at Stall Prevention during Acceleration           | 0.0 to 6000.0                    | 0.0 s                  | ×            | ×   | ○  |
|                            | L3-23               | Automatic Reduction Selection for Stall Prevention during Run       | 0,1                              | 0                      | ○            | ○   | ○  |
|                            | L3-24               | Motor Acceleration Time for Inertia Calculations                    | 0.001 to 10.000                  | dep. on drive capacity | ○            | ○   | ○  |
|                            | L3-25               | Load Inertia Ratio  | 0.0 to 1000.0                    | 1.0                    | ○            | ○   | ○  |
|                            | L4-01               | Speed Agreement Detection Level                                     | 0.0 to 400.0                     | 0.0 Hz                 | ○            | ○   | ○  |
|                            | L4-02               | Speed Agreement Detection Width                                     | 0.0 to 20.0                      | 2.0 Hz                 | ○            | ○   | ○  |
|                            | L4-03               | Speed Agreement Detection Level (+/-)                               | -400.0 to 400.0                  | 0.0 Hz                 | ○            | ○   | ○  |
|                            | L4-04               | Speed Agreement Detection Width (+/-)                               | 0.0 to 20.0                      | 2.0 Hz                 | ○            | ○   | ○  |
|                            | L4-05               | Frequency Reference Loss Detection Selection                        | 0,1                              | 0                      | ○            | ○   | ○  |
|                            | L4-06               | Frequency Reference at Reference Loss                               | 0.0 to 100.0                     | 80.0%                  | ○            | ○   | ○  |
| Frequency Detection        | L4-07               | Frequency Detection Conditions                                      | 0,1                              | 0                      | ○            | ○   | ○  |
|                            | L4-08               | Speed Agreement Condition Selection                                 | 0,1                              | 0                      | ○            | ○   | ○  |
|                            | L5-01               | Number of Auto Restart Attempts                                     | 0 to 10                          | 0                      | ○            | ○   | ○  |
|                            | L5-02               | Auto Restart Operation Selection                                    | 0,1                              | 0                      | ○            | ○   | ○  |
|                            | L5-04               | Fault Reset Interval Time   | 0.5 to 600.0                     | 10.0 s                 | ○            | ○   | ○  |
|                            | L5-05               | Fault Reset Operation Selection                                     | 0,1                              | 0                      | ○            | ○   | ○  |
|                            | L6-01               | Torque Detection Selection 1  | 0 to 8                           | 0                      | ○            | ○   | ○  |
|                            | L6-02               | Torque Detection Level 1  | 0 to 300                         | 150%                   | ○            | ○   | ○  |
|                            | L6-03               | Torque Detection Time 1   | 0.0 to 10.0                      | 0.1 s                  | ○            | ○   | ○  |
|                            | L6-04               | Torque Detection Selection 2  | 0 to 8                           | 0                      | ○            | ○   | ○  |
| Overtorque Detection       | L6-05               | Torque Detection Level 2  | 0 to 300                         | 150%                   | ○            | ○   | ○  |
|                            | L6-06               | Torque Detection Time 2   | 0.0 to 10.0                      | 0.1 s                  | ○            | ○   | ○  |
|                            | L6-08               | Mechanical Weakening (oL5) Detection Operation                      | 0 to 8                           | 0                      | ○            | ○   | ○  |
|                            | L6-09               | Mechanical Weakening Detection Speed Level                          | -110.0 to 110.0                  | 110%                   | ○            | ○   | ○  |
|                            | L6-10               | Mechanical Weakening Detection Time                                 | 0.0 to 10.0                      | 0.1 s                  | ○            | ○   | ○  |
|                            | L6-11               | Mechanical Weakening Detection Start Time                           | 0 to 65535                       | 0                      | ○            | ○   | ○  |

\*1: Default setting depends on the control mode.

\*2: L1-22 and L1-23 can only be displayed / setting when C6-02=B.

\*3: Values shown here are for 200 V class drives. Double the value when using a 400 V class drive.



# Basic Instructions

Outstanding operability! Separate settings for each application enables quick set-up.



## Operator Names and Functions

- Data display (5-digit)**  
Displays frequency, parameter number, and other data.
- LO/RE light**  
Lights to indicate that the operator is set for LOCAL.
- ESC key**  
Lets the user back up to the previous display screen.
- Right arrow key**  
Scrolls the cursor to the right.
- RESET key**  
Resets a fault.
- RUN light**  
Lights when the Run command is present.
- RUN key**  
Issues a Run command.
- Glossary**  
Used as a quick guide for the abbreviations used on the display screen. Details listed on the next page.

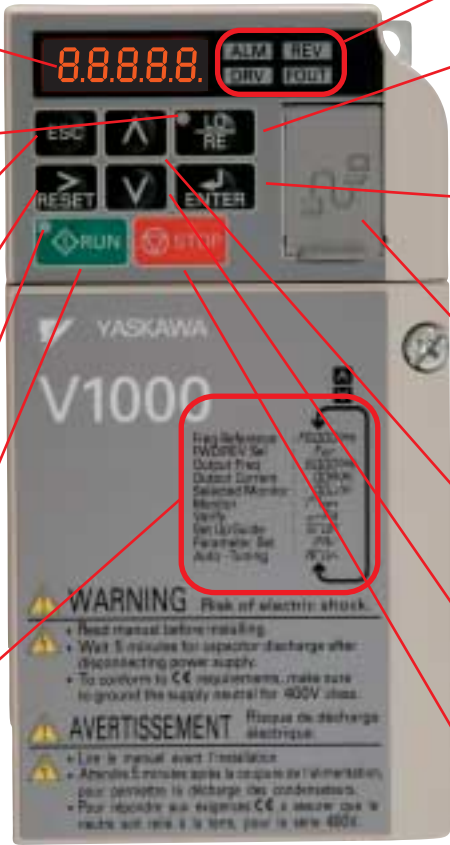

- LED panel**  
More information listed below.
- LO/RE key**  
Determines where the Run command and frequency reference come from: the keypad (LOCAL) or the control terminals (REMOTE).
- ENTER key**  
Press to enter values, edit parameters, and set the control mode. Press this key to proceed to the next screen when scrolling through various menu displays.
- Com port**  
For connecting to a PC (DriveWizard or DriveWork-eZ), a USB copy unit or a LCD operator.
- Up arrow key**  
Scrolls up through the display screen, and increases a selected value.
- Down arrow key**  
Scrolls down through the display screen, and decreases a selected value.
- STOP key**  
Issues a Stop command.



### LED Display Guide

| LED         | ON   | Flashing   | OFF                                 |
|-------------|--|--|-------------------------------------|
| <b>ALM</b>  | A fault has occurred.  | <ul style="list-style-type: none"> <li>• Alarm situation detected.</li> <li>• Operator error (OPE)</li> <li>• Auto-Tuning fault occurred.</li> </ul> | Normal operation                    |
| <b>REV</b>  | Motor is rotating in reverse.  | —  | Motor is rotating forward.          |
| <b>DRV</b>  | <ul style="list-style-type: none"> <li>• In the "Drive Mode"</li> <li>• Executing Auto-Tuning</li> </ul> | DriveWorksEZ is connected.   | Programming Mode                    |
| <b>FOUT</b> | Output frequency   | —  | —                                   |
| <b>RE</b>   | Run command assigned to the operator (LOCAL)   | —  | Control assigned to remote location |
| <b>RUN</b>  | During run   | <ul style="list-style-type: none"> <li>• During deceleration</li> <li>• Run command is present but the frequency reference is zero.</li> </ul>       | Drive is stopped.                   |

### How the RUN light works:

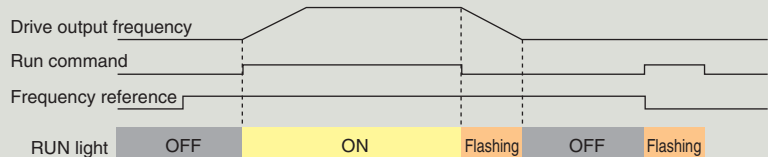



## Operation Example

### Using the LED Operator to Run the Drive

| Steps  | Key | Result/Display             |
|--|-----|----------------------------|
| 1 Turn the power on.   |     | F 0.00                     |
| 2 Set the drive for LOCAL. The frequency reference is displayed. |     | LO should light.<br>F 0.00 |
| 3 Displays the direction (forward).                              |     | For                        |
| 4 Displays the output frequency.                                 |     | 0.00                       |
| 5 Displays the output current.                                   |     | 0.00A                      |
| 6 Displays the output voltage.                                   |     | 0.00V                      |
| 7 Displays the beginning of the Monitor Menu.                    |     | flashing<br>Mnon           |
| 8 Displays the top of the Verify Menu.                           |     | flashing<br>urFY           |
| 9 Displays the top of the Setup Mode.                            |     | flashing<br>SRUP           |
| 10 Displays the top of the parameter settings menu.              |     | PAR                        |
| 11 Displays the top of the Auto-Tuning Mode.                     |     | ATUn                       |
| Returns back to the frequency reference display.                 |     |                            |

Value will flash when it is possible to change the setting.

**Drive Mode:** Run and Stop commands, displays operation status such as the frequency reference, output frequency, output current, output voltage, etc.

#### How to Monitor the Frequency Reference

| Steps   | Key | Result/Display               |
|---|-----|------------------------------|
| Use the arrow keys to select the digits to set. |     | F00.00                       |
|   |     | F00.00                       |
|   |     | F06.00                       |
| Increase or decrease the value displayed.       |     | F06.00                       |
| Press enter to save the new value.              |     | F06.00<br>DRV DRV lights up. |

**Monitor Mode:** Displays operation status and information on faults.

| Steps  | Key | Result/Display      |
|--|-----|---------------------|
| Select a monitor.                                |     | U1-01               |
| Displays U1-01, the frequency reference monitor. |     | 6.00                |
| Select another monitor.                          |     | U1-01               |
|  |     | U1-02               |
|  |     | ...                 |
|  |     | U1-26               |
| Back up to the top of the Monitor Menu.          |     | Mnon<br>Press once. |

**Verify Menu:** Lists all parameters that have been changed from their original default settings, either by the user or from Auto-Tuning.

| Steps  | Key | Result/Display      |
|--|-----|---------------------|
| Lists parameters that have been changed in order.                                |     | C1-01               |
| Pressing Enter displays the parameter value.                                     |     | 00030               |
| Parameters that have been changed from their default values are listed in order. |     | C1-01               |
|  |     | C1-02               |
|  |     | ...                 |
|  |     | C6-02               |
| Returns to the top of the Verify Menu.   |     | urFY<br>Press once. |

Press to go back to the previous display screen.

## Setup Mode

The list of Applications Presets can be accessed in the Setup Mode. Each Application Preset automatically programs drive parameters to their optimal settings specific to the application selected. All parameters affected by the Application Preset are then listed as Preferred Parameters for quick access. Selecting a Water Supply Pump (A1-06=1)

| Steps   | Key | Result/Display  |
|---|-----|---|
| Application Selection   |     | APPL  |
|   |     | 00  |
|   |     | 00  |
| Select, "Water Supply Pump".  |     | 01  |
| All parameters relating to the preset values for a water supply pump application are then listed as Preferred Parameters. |     | APPL  |
|   |     | Scroll to the Preferred Parameter using the up arrow key and see which parameters have been selected. |

#### Water Supply Pump Application Presets

| No.   | Parameter Name                                 | Optimum Setting     |
|-------|--|---------------------|
| A1-02 | Control Method Selection                       | 0: V/f control      |
| b1-04 | Reverse Operation Selection                    | 1: Reverse disabled |
| C1-01 | Acceleration Time 1                            | 1.0 (s)             |
| C1-02 | Deceleration Time 1                            | 1.0 (s)             |
| C6-01 | Normal/Heavy Duty Selection                    | 1: Normal Duty (ND) |
| E1-03 | V/f Pattern Selection                          | 0F (H)              |
| E1-07 | Mid Output Frequency                           | 30.0 (Hz)           |
| E1-08 | Mid Output Frequency Voltage                   | 50.0 (V)            |
| L2-01 | Momentary Power Loss Operation Selection       | 1: Enabled          |
| L3-04 | Stall Prevention Selection during Deceleration | 1: Enabled          |

#### Preferred Parameters

| No.   | Parameter Name                  | No.   | Parameter Name  |
|-------|---------------------------------|-------|---|
| b1-01 | Frequency Reference Selection 1 | E1-08 | Mid Output Frequency Voltage (VC)                           |
| b1-02 | Run Command Selection 1         | E2-01 | Motor Rated Current   |
| b1-04 | Reverse Operation Selection     | H1-05 | Multi-Function Digital Input Terminal S5 Function Selection |
| C1-01 | Acceleration Time 1             | H1-06 | Multi-Function Digital Input Terminal S6 Function Selection |
| C1-02 | Deceleration Time 1             | H1-07 | Multi-Function Digital Input Terminal S7 Function Selection |
| E1-03 | V/f Pattern Selection           | L5-01 | Number of Auto Restart Attempts                             |
| E1-07 | Mid Output Frequency            | -     | -   |

# Product Lineup

Number in parenthesis indicates the rated output current.

| Motor Capacity kW | Three-Phase 200 V          |                           | Single-Phase 200 V       |                           | Three-Phase 400 V         |                           |
|-------------------|----------------------------|---------------------------|--------------------------|---------------------------|---------------------------|---------------------------|
|                   | Normal Duty                | Heavy Duty                | Normal Duty              | Heavy Duty                | Normal Duty               | Heavy Duty                |
| 0.1               |                            | CIMR-VA2A0001<br>(0.8 A)  |                          | CIMR-VABA0001<br>(0.8 A)  |                           |                           |
| 0.2               | CIMR-VA2A0001<br>(1.2 A)   | CIMR-VA2A0002<br>(1.6 A)  | CIMR-VABA0001<br>(1.2 A) | CIMR-VABA0002<br>(1.6 A)  |                           | CIMR-VA4A0001<br>(1.2 A)  |
| 0.4               | CIMR-VA2A0002<br>(1.9 A)   | CIMR-VA2A0004<br>(3 A)    | CIMR-VABA0002<br>(1.9 A) | CIMR-VABA0003<br>(3 A)    | CIMR-VA4A0001<br>(1.2 A)  | CIMR-VA4A0002<br>(1.8 A)  |
| 0.75              | CIMR-VA2A0004<br>(3.5 A)   | CIMR-VA2A0006<br>(5 A)    | CIMR-VABA0003<br>(3.3 A) | CIMR-VABA0006<br>(5 A)    | CIMR-VA4A0002<br>(2.1 A)  | CIMR-VA4A0004<br>(3.4 A)  |
| 1.1               | CIMR-VA2A0006<br>(6 A)     | CIMR-VA2A0008*<br>(6.9 A) | CIMR-VABA0006<br>(6 A)   |                           |                           |                           |
| 1.5               | CIMR-VA2A0008*<br>(8 A)    | CIMR-VA2A0010<br>(8 A)    |                          | CIMR-VABA0010<br>(8 A)    | CIMR-VA4A0004<br>(4.1 A)  | CIMR-VA4A0005<br>(4.8 A)  |
| 2.2               | CIMR-VA2A0010<br>(9.6 A)   | CIMR-VA2A0012<br>(11 A)   | CIMR-VABA0010<br>(9.6 A) | CIMR-VABA0012<br>(11 A)   | CIMR-VA4A0005<br>(5.4 A)  | CIMR-VA4A0007<br>(5.5 A)  |
| 3.0               | CIMR-VA2A0012<br>(12 A)    | CIMR-VA2A0018*<br>(14 A)  | CIMR-VABA0012<br>(12 A)  |                           | CIMR-VA4A0007<br>(6.9 A)  | CIMR-VA4A0009<br>(7.2 A)  |
| 3.7               | CIMR-VA2A0018*<br>(17.5 A) | CIMR-VA2A0020<br>(17.5 A) |                          | CIMR-VABA0018<br>(17.5 A) | CIMR-VA4A0009<br>(8.8 A)  | CIMR-VA4A0011<br>(9.2 A)  |
| 5.5               | CIMR-VA2A0020<br>(19.6 A)  | CIMR-VA2A0030<br>(25 A)   |                          |                           | CIMR-VA4A0011<br>(11.1 A) | CIMR-VA4A0018<br>(14.8 A) |
| 7.5               | CIMR-VA2A0030<br>(30 A)    | CIMR-VA2A0040<br>(33 A)   |                          |                           | CIMR-VA4A0018<br>(17.5 A) | CIMR-VA4A0023<br>(18 A)   |
| 11                | CIMR-VA2A0040<br>(40 A)    | CIMR-VA2A0056<br>(47 A)   |                          |                           | CIMR-VA4A0023<br>(23 A)   | CIMR-VA4A0031<br>(24 A)   |
| 15                | CIMR-VA2A0056<br>(56 A)    | CIMR-VA2A0069<br>(60 A)   |                          |                           | CIMR-VA4A0031<br>(31 A)   | CIMR-VA4A0038<br>(31 A)   |
| 18.5              | CIMR-VA2A0069<br>(69 A)    |                           |                          |                           | CIMR-VA4A0038<br>(38 A)   |                           |

\*: Available in Japan only

## Model Number Key

**CIMR- V A 2 A 0001 B A A**

AC Drive V1000 Series      Design Revision Order

| No. | Region Code | No. | Voltage Class        | No. | Customized Specifications  | No. | Output Current A  | No. | Enclosure Type | No. | Environmental Specification |
|-----|-------------|-----|----------------------|-----|--|-----|---|-----|----------------|-----|-----------------------------|
| T   | Asia        | B   | 1-Phase, 200-240 Vac |     |  |     |   | B   | IP20           | A   | Standard                    |
| A   | Japan       | 2   | 3-Phase, 200-240 Vac | A   | Standard model   |     | Note: Indicates the rated output current of the Normal Duty rating rounded off to the nearest whole number. | F   | NEMA1          | M   | Humidity, dust              |
|     |             | 4   | 3-Phase, 380-480 Vac |     |  |     |   | J   | Finless (IP20) | N   | Oil                         |
|     |             |     |                      |     | Note: Contact a Yaskawa representative for more information on high frequency custom software. |     |   |     |                | S   | Shock, vibration            |
|     |             |     |                      |     |  |     |   |     |                | K   | Gas                         |

Note: Contact a Yaskawa representative for more on environmental specifications.

# Model Selection

## Optimizing Control for Each Application

V1000 offers two separate performance ratings: Normal Duty and Heavy Duty.

Heavy Duty is capable of creating more powerful torque, while Normal Duty allows the drive to operate a larger motor.

Difference between load ratings:

|                    | Normal Duty Rating                 | Heavy Duty Rating      |
|--------------------|------------------------------------|------------------------|
| Parameter settings | C6-01 = 1 (default)                | C6-01 = 0              |
| Overload tolerance | 120% for 60 s                      | 150% for 60 s          |
| Carrier frequency  | Low carrier frequency (Swing PWM)* | High carrier frequency |

\*: Use Swing PWM to quiet undesirable motor noise generated when operating with a low carrier frequency.

### Normal Duty Applications



### Heavy Duty Applications



\*The applications shown above can still use the ND rating, provided that the maximum torque required is no more than 120% for 60 s.

#### ● Selecting a Drive

For a fan application using a 0.75 kW motor, select CIMR-VA2A0004 and set it for Normal Duty performance.

Model: CIMR-VA2A0004

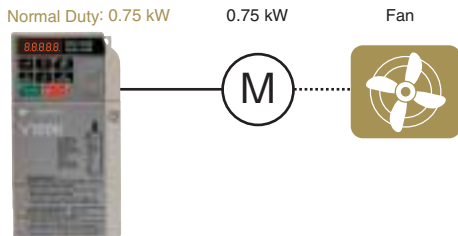

#### ● Selecting a Drive

For a chain block application using a 0.75 kW motor, select CIMR-VA2A0006 and set it for Heavy Duty performance.

Model: CIMR-VA2A0006

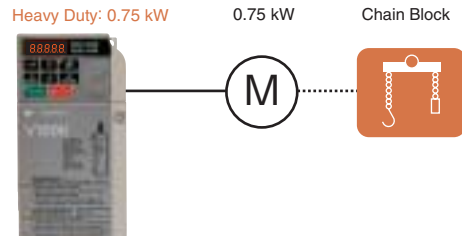

Use the table below to transition from VS mini V7 to the V1000 series (assumes a Heavy Duty rating).

| Max. Applicable Motor Capacity kW | Power Supply Model | 200 V                            |                            |                                  |                            | 400 V                            |                            |
|-----------------------------------|--------------------|----------------------------------|----------------------------|----------------------------------|----------------------------|----------------------------------|----------------------------|
|                                   |                    | Three-Phase                      |                            | Single-Phase                     |                            | Three-Phase                      |                            |
|                                   |                    | VS mini V7<br>CIMR-<br>V7AA2□□□□ | V1000<br>CIMR-<br>VA2A□□□□ | VS mini V7<br>CIMR-<br>V7AAB□□□□ | V1000<br>CIMR-<br>VABA□□□□ | VS mini V7<br>CIMR-<br>V7AA4□□□□ | V1000<br>CIMR-<br>VA4A□□□□ |
| 0.1                               |                    | 0P1                              | 0001                       | 0P1                              | 0001                       | —                                | —                          |
| 0.2                               |                    | 0P2                              | 0002                       | 0P2                              | 0002                       | 0P2                              | 0001                       |
| 0.4                               |                    | 0P4                              | 0004                       | 0P4                              | 0003                       | 0P4                              | 0002                       |
| 0.75                              |                    | 0P7                              | 0006                       | 0P7                              | 0006                       | 0P7                              | 0004                       |
| 1.5                               |                    | 1P5                              | 0010                       | 1P5                              | 0010                       | 1P5                              | 0005                       |
| 2.2                               |                    | 2P2                              | 0012                       | 2P2                              | 0012                       | 2P2                              | 0007                       |
| 3.7                               |                    | 3P7                              | 0020                       | 3P7                              | 0018                       | 3P7                              | 0011                       |
| 5.5                               |                    | 5P5                              | 0030                       | —                                | —                          | 5P5                              | 0018                       |
| 7.5                               |                    | 7P5                              | 0040                       | —                                | —                          | 7P5                              | 0023                       |
| 11                                |                    | —                                | 0056                       | —                                | —                          | —                                | 0031                       |
| 15                                |                    | —                                | 0069                       | —                                | —                          | —                                | 0038                       |

# Standard Specifications

Parameter C6-01 sets the drive for Normal Duty or Heavy Duty performance.

## 200 V Class (Three-Phase/Single-Phase)

Value in brackets is for a single-phase drive.

| Model                            | Three-Phase CIMR-VA2A         | 0001   | 0002                    | 0004  | 0006  | 0008*10   | 0010  | 0012  | 0018*10 | 0020   | 0030   | 0040   | 0056   | 0069   |        |        |
|----------------------------------|-------------------------------|--|-------------------------|-------|-------|-----------|-------|-------|---------|--------|--------|--------|--------|--------|--------|--------|
|                                  | Single-Phase*2 CIMR-VABA      | 0001   | 0002                    | 0003  | 0006  | -         | 0010  | 0012  | -       | 0018*1 | -      | -      | -      | -      |        |        |
| Max. Applicable Motor Capacity*3 | kW                            | Normal Duty  | 0.2                     | 0.4   | 0.75  | 1.1       | 1.5   | 2.2   | 3.0     | 3.7    | 5.5    | 7.5    | 11.0   | 15.0   | 18.5   |        |
|                                  |                               | Heavy Duty   | 0.1                     | 0.2   | 0.4   | 0.75      | 1.1   | 1.5   | 2.2     | 3.0    | 3.7    | 5.5    | 7.5    | 11.0   | 15.0   |        |
| Input                            | Rated Input Current*4         | A  | Three-phase Normal Duty | 1.1   | 1.9   | 3.9       | 7.3   | 8.8   | 10.8    | 13.9   | 18.5   | 24.0   | 37.0   | 52.0   | 68.0   | 80.0   |
|                                  |                               |  | Three-phase Heavy Duty  | 0.7   | 1.5   | 2.9       | 5.8   | 7.0   | 7.5     | 11.0   | 15.6   | 18.9   | 24.0   | 37.0   | 52.0   | 68.0   |
|                                  |                               | Single-phase   | Normal Duty             | 2.0   | 3.6   | 7.3       | 13.8  | -     | 20.2    | 24.0   | -      | -      | -      | -      | -      | -      |
|                                  |                               |  | Heavy Duty              | 1.4   | 2.8   | 5.5       | 11.0  | -     | 14.1    | 20.6   | -      | 35.0   | -      | -      | -      | -      |
| Output                           | Rated Output Capacity*5       | kVA  | Normal Duty*6           | 0.5   | 0.7   | 1.3       | 2.3   | 3.0   | 3.7     | 4.6    | 6.7    | 7.5    | 11.4   | 15.2   | 21.3   | 26.3   |
|                                  |                               |  | Heavy Duty              | 0.3*7 | 0.6*7 | 1.1*7     | 1.9*7 | 2.6*8 | 3.0*8   | 4.2*8  | 5.3*8  | 6.7*8  | 9.5*8  | 12.6*8 | 17.9*8 | 22.9*8 |
|                                  | Rated Output Current          | A  | Normal Duty*6           | 1.2   | 1.9   | 3.5 (3.3) | 6.0   | 8.0   | 9.6     | 12.0   | 17.5   | 19.6   | 30.0   | 40.0   | 56.0   | 69.0   |
|                                  |                               |  | Heavy Duty              | 0.8*7 | 1.6*7 | 3.0*7     | 5.0*7 | 6.9*8 | 8.0*8   | 11.0*8 | 14.0*8 | 17.5*8 | 25.0*8 | 33.0*8 | 47.0*8 | 60.0*8 |
|                                  | Overload Tolerance            | Normal Duty Rating: 120% of rated output current for 60 s.<br>Heavy Duty Rating: 150% of rated output current for 60 s.<br>(Derating may be required for repetitive loads) |                         |       |       |           |       |       |         |        |        |        |        |        |        |        |
|                                  | Carrier Frequency             | 2 kHz (user-set, 2 to 15 kHz possible)   |                         |       |       |           |       |       |         |        |        |        |        |        |        |        |
|                                  | Max. Output Voltage           | Three-phase power supply: three-phase 200 to 240 V (relative to input voltage)<br>Single-phase power supply: three-phase 200 to 240 V (relative to input voltage)          |                         |       |       |           |       |       |         |        |        |        |        |        |        |        |
|                                  | Max. Output Frequency         | 400 Hz (user-set)  |                         |       |       |           |       |       |         |        |        |        |        |        |        |        |
|                                  | Rated Voltage/Rated Frequency | Three-phase AC power supply: three-phase 200 to 240 V 50/60 Hz DC power supply: 270 to 340 V*9<br>Single-phase AC power supply: single-phase 200 to 240 V 50/60 Hz         |                         |       |       |           |       |       |         |        |        |        |        |        |        |        |
|                                  | Allowable Voltage Fluctuation | -15 to +10%  |                         |       |       |           |       |       |         |        |        |        |        |        |        |        |
| Allowable Frequency Fluctuation  | ±5%                           |  |                         |       |       |           |       |       |         |        |        |        |        |        |        |        |
| Power                            | Power Supply                  | kVA  | Three-phase Normal Duty | 0.5   | 0.9   | 1.8       | 3.3   | 4.0   | 4.9     | 6.4    | 8.5    | 11.0   | 17.0   | 24.0   | 31.0   | 37.0   |
|                                  |                               |  | Three-phase Heavy Duty  | 0.3   | 0.7   | 1.3       | 2.7   | 3.2   | 3.4     | 5.0    | 7.1    | 8.6    | 11.0   | 17.0   | 24.0   | 31.0   |
|                                  |                               | Single-phase   | Normal Duty             | 0.5   | 1.0   | 1.9       | 3.6   | -     | 5.3     | 6.3    | -      | -      | -      | -      | -      | -      |
|                                  |                               |  | Heavy Duty              | 0.4   | 0.7   | 1.5       | 2.9   | -     | 3.7     | 5.4    | -      | 9.2    | -      | -      | -      | -      |

\*1: Heavy Duty (3.7 kW) only.

\*2: Drives with a single-phase power supply input have three-phase output. Single-phase motors cannot be used.

\*3: The motor capacity (kW) refers to a Yaskawa 4-pole, 60 Hz, 200 V motor. The rated output current of the drive output amps should be equal to or greater than the motor rated current.

\*4: Value displayed is for the input current when operating Yaskawa standard motors of max. applicable capacity with the rated load at the rated motor speed. This value may fluctuate based on the power supply side impedance, as well as the power supply transformer, input side reactor, and wiring conditions.

\*5: Rated output capacity is calculated with a rated output voltage of 220 V.

\*6: This value assumes a carrier frequency of 2 kHz. Increasing the carrier frequency requires a reduction in current.

\*7: This value assumes a carrier frequency of 10 kHz. Increasing the carrier frequency requires a reduction in current.

\*8: This value assumes a carrier frequency of 8 kHz. Increasing the carrier frequency requires a reduction in current.

\*9: Not compliant with UL or CE standards when using a DC power supply.

\*10: These models are available in Japan only.

## 400 V Class (Three-phase)

| Model                            | CIMR-VA4A  | 0001        | 0002          | 0004 | 0005 | 0007 | 0009 | 0011 | 0018 | 0023 | 0031 | 0038 |      |      |
|----------------------------------|--|-------------|---------------|------|------|------|------|------|------|------|------|------|------|------|
| Max. Applicable Motor Capacity*1 | kW   | Normal Duty | 0.4           | 0.75 | 1.5  | 2.2  | 3.0  | 3.7  | 5.5  | 7.5  | 11.0 | 15.0 | 18.5 |      |
|                                  |  | Heavy Duty  | 0.2           | 0.4  | 0.75 | 1.5  | 2.2  | 3.0  | 3.7  | 5.5  | 7.5  | 11.0 | 15.0 |      |
| Input                            | Rated Input Current*2  | A           | Normal Duty   | 1.2  | 2.1  | 4.3  | 5.9  | 8.1  | 9.4  | 14.0 | 20.0 | 24.0 | 38.0 | 44.0 |
|                                  |  |             | Heavy Duty    | 1.2  | 1.8  | 3.2  | 4.4  | 6.0  | 8.2  | 10.4 | 15.0 | 20.0 | 29.0 | 39.0 |
| Output                           | Rated Output Capacity*3  | kVA         | Normal Duty*4 | 0.9  | 1.6  | 3.1  | 4.1  | 5.3  | 6.7  | 8.5  | 13.3 | 17.5 | 23.6 | 29.0 |
|                                  |  |             | Heavy Duty*5  | 0.9  | 1.4  | 2.6  | 3.7  | 4.2  | 5.5  | 7.0  | 11.3 | 13.7 | 18.3 | 23.6 |
|                                  | Rated Output Current   | A           | Normal Duty*4 | 1.2  | 2.1  | 4.1  | 5.4  | 6.9  | 8.8  | 11.1 | 17.5 | 23.0 | 31.0 | 38.0 |
|                                  |  |             | Heavy Duty*5  | 1.2  | 1.8  | 3.4  | 4.8  | 5.5  | 7.2  | 9.2  | 14.8 | 18.0 | 24.0 | 31.0 |
| Overload Tolerance               | Normal Duty Rating: 120% of rated output current for 60 s.<br>Heavy Duty Rating: 150% of rated output current for 60 s.<br>(Derating may be required for repetitive loads) |             |               |      |      |      |      |      |      |      |      |      |      |      |
| Carrier Frequency                | 2 kHz (user-set, 2 to 15 kHz possible)   |             |               |      |      |      |      |      |      |      |      |      |      |      |
| Max. Output Voltage              | Three-phase 380 to 480 V (relative to input voltage)   |             |               |      |      |      |      |      |      |      |      |      |      |      |
| Max. Output Frequency            | 400 Hz (user-set)  |             |               |      |      |      |      |      |      |      |      |      |      |      |
| Rated Voltage/Rated Frequency    | Three-phase AC power supply 380 to 480 V 50/60 Hz DC power supply: 510 to 680 V*6  |             |               |      |      |      |      |      |      |      |      |      |      |      |
| Allowable Voltage Fluctuation    | -15 to +10%  |             |               |      |      |      |      |      |      |      |      |      |      |      |
| Allowable Frequency Fluctuation  | ±5%  |             |               |      |      |      |      |      |      |      |      |      |      |      |
| Power                            | Power Supply   | kVA         | Normal Duty   | 1.1  | 1.9  | 3.9  | 5.4  | 7.4  | 8.6  | 13.0 | 18.0 | 22.0 | 35.0 | 40.0 |
|                                  |  |             | Heavy Duty    | 1.1  | 1.6  | 2.9  | 4.0  | 5.5  | 7.5  | 9.5  | 14.0 | 18.0 | 27.0 | 36.0 |

\*1: The motor capacity (kW) refers to a Yaskawa 4-pole, 60 Hz, 400 V motor. The rated output current of the drive output amps should be equal to or greater than the motor rated current.

\*2: Value displayed is for the input current when operating Yaskawa standard motors of max. applicable capacity with the rated load at the rated motor speed. This value may fluctuate based on the power supply side impedance, as well as the power supply transformer, input side reactor, and wiring conditions.

\*3: Rated output capacity is calculated with a rated output voltage of 440 V.

\*4: This value assumes a carrier frequency of 2 kHz. Increasing the carrier frequency requires a reduction in current.

\*5: This value assumes a carrier frequency of 8 kHz. Increasing the carrier frequency requires a reduction in current.

\*6: Not compliant with UL or CE standards when using a DC power supply.

## Common Specifications

Rotational Auto-Tuning must be performed to achieve the performance described with Open Loop Vector Control.

|                         | Item  | Specifications   |
|-------------------------|---|--|
| Control Characteristics | Control Method  | Open Loop Vector Control (Current Vector), V/f Control, PM Open Loop Vector Control (for SPM and IPM motors)   |
|                         | Frequency Control Range   | 0.01 to 400 Hz   |
|                         | Frequency Accuracy (Temperature Fluctuation)  | Digital reference: within $\pm 0.01\%$ of the max. output frequency ( $-10$ to $+50^{\circ}\text{C}$ )   |
|                         |   | Analog reference: within $\pm 0.1\%$ of the max. output frequency ( $25 \pm 10^{\circ}\text{C}$ )  |
|                         | Frequency Setting Resolution  | Digital reference: 0.01 Hz   |
|                         |   | Analog reference: 1/1000 of max. frequency   |
|                         | Output Frequency Resolution   | 20 bit of maximum output frequency (parameter E1-04 setting)   |
|                         | Frequency Setting Resolution  | Main frequency reference: 0 to 10 Vdc (20 k $\Omega$ ), 4 to 20 mA (250 $\Omega$ ), 0 to 20 mA (250 $\Omega$ )<br>Main speed reference : Pulse Train Input (max. 32 kHz)   |
|                         | Starting Torque   | 200% / 0.5 Hz (assumes Heavy Duty rating IM of 3.7 kW or less using Open Loop Vector Control), 50% / 6 Hz (assumes PM Open Loop Vector Control)  |
|                         | Speed Control Range   | 1:100 (Open Loop Vector Control), 1:20 to 40 (V/f Control), 1:10 (PM Open Loop Vector Control)   |
|                         | Speed Control Accuracy  | $\pm 0.2\%$ in Open Loop Vector Control ( $25 \pm 10^{\circ}\text{C}$ ) *1   |
|                         | Speed Response  | 5 Hz in Open Loop Vector ( $25 \pm 10^{\circ}\text{C}$ ) (excludes temperature fluctuation when performing Rotational Auto-Tuning)   |
|                         | Torque Limit  | Open Loop Vector Control allows separate settings in four quadrants  |
|                         | Accel/Decel Time  | 0.0 to 6000.0 s (4 selectable combinations of independent acceleration and deceleration settings)  |
| Protection Function     | Braking Torque  | ① Short-time decel torque*2: over 150% for 0.1/0.2 kW motors, over 100% for 0.4/ 0.75 kW motors, over 50% for 1.5 kW motors, and over 20% for 2.2 kW and above motors (overexcitation braking/High-Slip Braking: approx. 40%)<br>② Continuous regen. torque: approx. 20% (approx. 125% with dynamic braking resistor option*3: 10% ED, 10 s, internal braking transistor)  |
|                         | V/f Characteristics   | User-selected programs, V/f preset patterns possible   |
|                         | Main Control Functions  | Momentary power loss ride-thru, Speed search, Overtorque detection, Torque limit, 17-step speed (max), Accel/decel time switch, S-curve accel/decels, 3-wire sequence, Auto-tuning (rotational, stationary tuning for resistance between lines), Dwell, Cooling fan on/off switch, Slip compensation, Torque compensation, Frequency jump, Upper/lower limits for frequency reference, DC injection braking at start and stop, Overexcitation braking, High slip braking, PID control (with sleep function), Energy saving control, MEMOBUS comm. (RS-485/422 max, 115.2 kbps), Fault restart, Application presets, DriveWorksEZ (customized function), Removable terminal block with parameter backup function... |
| Operating Environment   | Motor Protection  | Motor overheat protection based on output current  |
|                         | Momentary Overcurrent Protection  | Drive stops when output current exceeds 200% of Heavy Duty Rating  |
|                         | Overload Protection   | Drive stops after 60 s at 150% of rated output current (Heavy Duty Rating)*4   |
|                         | Overvoltage Protection  | 200 V class: Stops when DC bus exceeds approx. 410 V   |
|                         |   | 400 V class: Stops when DC bus exceeds approx. 820 V (approx. 740 V when power supply voltage is less than 400 V)  |
|                         | Undervoltage Protection   | Three-phase 200 V class: Stops when DC bus falls below approx. 190 V   |
|                         |   | Single-phase 200 V class: Stops when DC bus falls below approx. 160 V<br>Three-phase 400 V class: Stops when DC bus falls below approx. 380 V (approx. 350 V when the power supply voltage is less than 400 V)   |
|                         | Momentary Power Loss Ride-Thru  | Stops after approx. 15 ms (default). Parameter settings allow the drive to continue running if power loss lasts for up to approx. 2 s *5   |
|                         | Heatsink Overheat Protection  | Protection by thermistor   |
|                         | Braking Resistance Overheat Protection  | Overheat sensor for braking resistor (optional ERF-type, 3% ED)  |
| Stall Prevention        | Separate settings allowed during acceleration, and during run. Enable/disable only during deceleration. |  |
| Ground Fault Protection | Protection by electronic circuit *6   |  |
| Charge LED              | Charge LED remains lit until DC bus has fallen below approx. 50 V                                       |  |
| Standards Compliance    | Area of Use   | Indoors  |
|                         | Ambient Temperature   | $-10$ to $+50^{\circ}\text{C}$ (open chassis), $-10$ to $+40^{\circ}\text{C}$ (NEMA Type 1)  |
|                         | Humidity  | 95 RH% or less (no condensation)   |
|                         | Storage Temperature   | $-20$ to $+60^{\circ}\text{C}$ (short-term temperature during transportation)  |
|                         | Altitude  | Up to 1000 meters  |
| Protection Design       | Shock   | 10 to less than 20 Hz (9.8 m/s <sup>2</sup> ) max., 20 to 55 Hz (5.9 m/s <sup>2</sup> ) max.   |
|                         | Standards Compliance  | ·UL508C<br>·EN61800-3, EN61800-5-1<br>·ISO13849-1 Cat.3 PLd, IEC61508 SIL2   |
| Protection Design       | IP20 open-chassis, NEMA Type 1 enclosure  |  |

\*1: Speed control accuracy may vary slightly depending on installation conditions or motor used.

\*2: Momentary average deceleration torque refers to the deceleration torque from 60Hz down to 0 Hz. This may vary depending on the motor.

\*3: Disable Stall Prevention during deceleration by setting L3-04 (Stall Prevention Selection during Deceleration) to 0 (disabled) or 3 (stall prevention with braking resistor) when using a Braking Resistor or Braking Resistor Unit. The motor may not stop within the deceleration time if this setting is not changed.

\*4: Overload protection may be triggered at lower levels if output frequency is below 6 Hz.

\*5: Varies by drive capacity. Drives smaller than 7.5 kW (CIMR-VA2A0040/ CIMR-VA4A0023) require a separate Momentary Power Loss Recovery Unit to continue operating during a momentary power loss of 2 s.

\*6: Protection may not be provided under the following conditions as the motor windings are grounded internally during run:  
· Low resistance to ground from the motor cable or terminal block.  
· Drive already has a short-circuit when the power is turned on.



# Standard Connection Diagram

## Standard Connection Diagram

Example: 200 V Class

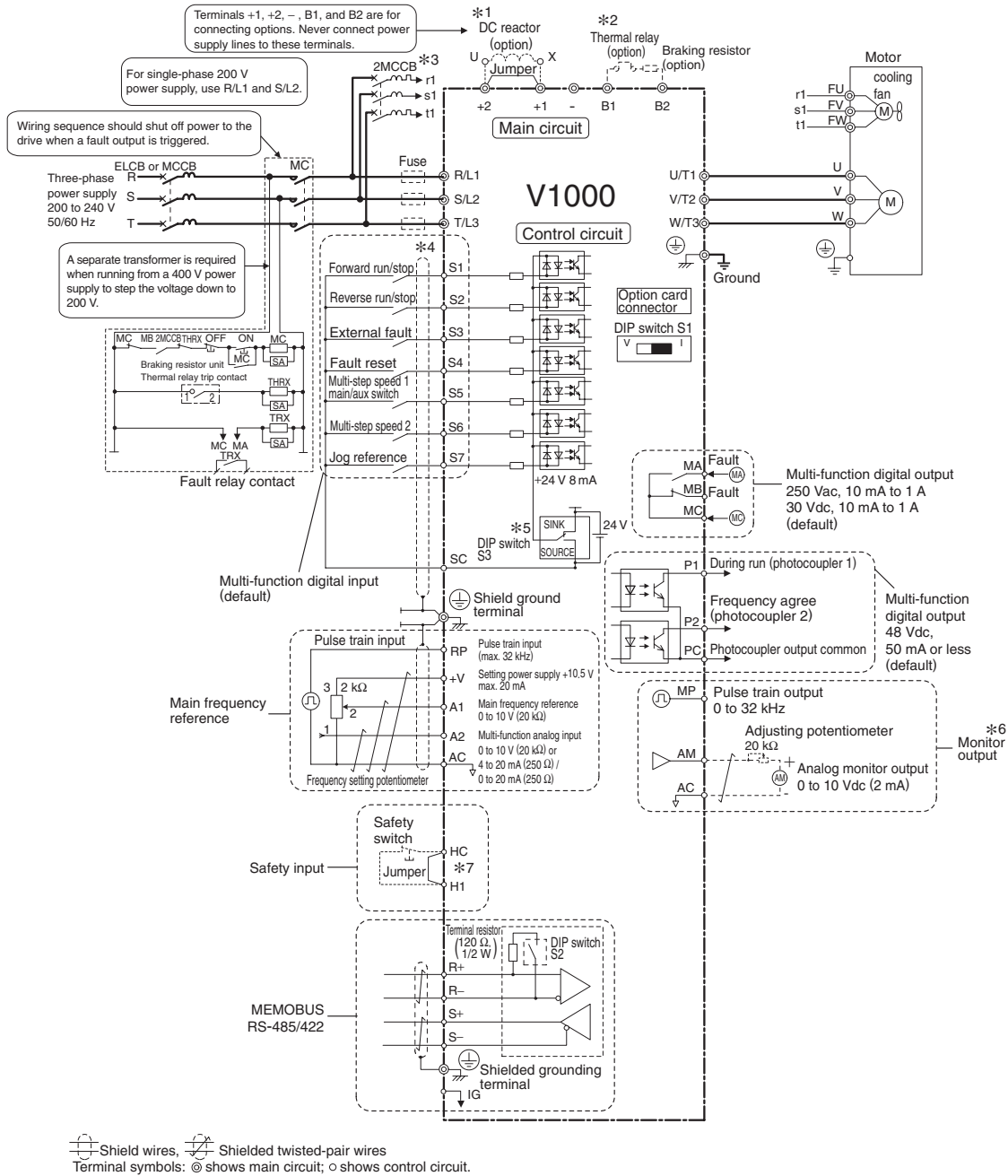

- \*1: Remove the jumper between terminals +1 and +2 when installing an optional DC reactor.
  - \*2: The MC on the input side of the main circuit should open when the thermal relay is triggered.
  - \*3: Self-cooled motors do not require separate cooling fan motor wiring.
  - \*4: Connected using sequence (0 V com/sink mode) input signal (S1 to S7) from NPN transistor (default).
  - \*5: Sinking mode requires an internal 24 V power supply. Source mode requires an external power supply.
  - \*6: Monitor outputs work with devices such as analog frequency meters, current meters, voltmeters and watt meters. They cannot be used in a control system requiring feedback.
  - \*7: When using an external switch to stop the drive as a safety precaution, make sure the jumper creating the short circuit has been removed. Output is interrupted within 1 ms after the safety input is triggered. Make sure safety input wiring does not exceed 30 m.
- Note: Input terminal functions may change when Application Presets are used.

### Control Circuit and Terminal Layout

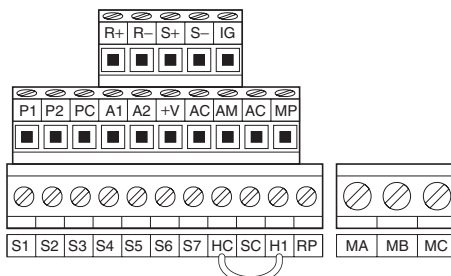

## Terminal Functions

### Main Circuit Terminals

| Terminal             | Terminal Name                   | Function (Signal Level)   |
|----------------------|---------------------------------|---|
| R/L1<br>S/L2<br>T/L3 | Main circuit power supply input | Connects line power to the drive.<br>Drives with single-phase 200 V input power use terminals R/L1 and S/L2 only (do not use T/L3). |
| U/T1<br>V/T2<br>W/T3 |                                 |   |
| B1<br>B2             |                                 |   |
| +1<br>+2             | DC reactor connection           | These terminals are shorted for shipment. Remove the jumper creating the short to install a DC choke.                               |
| +1<br>-              | DC power supply input           | For connecting a DC power supply.<br>DC power supply input terminals (+1, -) are not UL/cUL and CE certified.                       |
| ⊕ Two terminals      | Ground                          | Grounding terminal<br>Grounding resistance for 200 V class: 100 Ω or less<br>Grounding resistance for 400 V class: 10 Ω or less     |

### Control Circuit Input Terminals

| Terminal                           | No. | Terminal Name                                | Function (Signal Level)   |
|------------------------------------|-----|--|---|
| Multi-function digital input       | S1  | Multi-function input 1                       | Photocoupler<br>24 Vdc, 8 mA<br>Note: Drive preset to sinking mode. When using source mode, set DIP switch S3 to allow for a 24 Vdc (±10%) external power supply.     |
|                                    | S2  | Multi-function input 2                       |   |
|                                    | S3  | Multi-function input 3                       |   |
|                                    | S4  | Multi-function input 4                       |   |
|                                    | S5  | Multi-function input 5                       |   |
|                                    | S6  | Multi-function input 6                       |   |
|                                    | S7  | Multi-function input 7                       |   |
|                                    | SC  | Multi-function input common (Control common) |   |
| Main frequency reference input     | RP  | Multi-function pulse train input             | Input frequency: 0.5 to 32 kHz<br>(Duty cycle: 30 to 70%) (High level voltage: 3.5 to 13.2 V)<br>(Low level voltage: 0.0 to 0.8 V) (Input impedance: 3 kΩ)            |
|                                    | +V  | Analog input power supply                    | +10.5 V (max. allowable current 20 mA)  |
|                                    | A1  | Main frequency reference                     | Input voltage<br>0 to 10 Vdc (20 kΩ) resolution: 1/1000   |
|                                    | A2  | Multi-function analog input                  | DIP switch S1 sets the terminal for a voltage or current input signal<br>0 to 10 Vdc (20 kΩ) resolution: 1/1000<br>4 to 20 mA or 0 to 20 mA (250 Ω) resolution: 1/500 |
|                                    | AC  | Frequency reference common                   | 0 V   |
| Hardware baseblock                 | HC  | Power supply for hardware baseblock command  | +24 Vdc (max. 10 mA allowed)  |
|                                    | H1  | Safety Input                                 | Open: Hardware baseblock<br>Closed: Normal operation  |
| Multi-function digital output*1    | MA  | N.O. output                                  | Digital output<br>30 Vdc (or less), 10 mA to 1 A<br>250 Vac (or less), 10 mA to 1 A   |
|                                    | MB  | N.C. output                                  |   |
|                                    | MC  | Digital output common                        |   |
| Multi-function photocoupler output | P1  | Photocoupler output 1                        | Photocoupler output *2<br>48 Vdc (or less), 50 mA (or less)   |
|                                    | P2  | Photocoupler output 2                        |   |
|                                    | PC  | Photocoupler output common                   |   |
| Monitor output                     | MP  | Pulse train output                           | 32 kHz (max.)   |
|                                    | AM  | Analog monitor output                        | 0 to 10 Vdc (2 mA or less)<br>Resolution: 1/1000  |
|                                    | AC  | Monitor common                               | 0 V   |

\*1: Refrain from assigning functions to terminals MA and MB that involve frequent switching, as doing so may shorten relay performance life. Switching life is estimated at 200,000 times (assumes 1 A, resistive load).

\*2: Connect a flywheel diode as shown in the figure on the right when driving a reactive load such as a relay coil. Make sure the diode rating is greater than the circuit voltage.

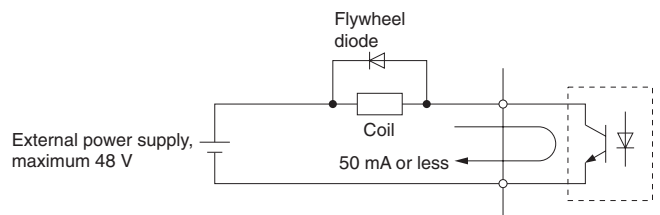

### Serial Communication Terminals

| Type                  | No. | Terminal Name             | Function (Signal Level)   |
|-----------------------|-----|---------------------------|---|
| MEMOBUS communication | R+  | Communications input (+)  | MEMOBUS communication:<br>· Use a RS-485 or RS-422 cable to connect the drive.<br>· RS-485/422 MEMOBUS communication protocol 115.2 kbps (max.) |
|                       | R-  | Communications input (-)  |   |
|                       | S+  | Communications output (+) |   |
|                       | S-  | Communications output (-) |   |
|                       | IG  | Shielded ground           |   |



# Dimensions

## Enclosures

Enclosures of standard products vary depending on the model. Refer to the table below.

### 200 V Class (Single/Three-Phase)

| Model                          | Three-Phase CIMR-VA2A  | 0001                                    | 0002 | 0004 | 0006 | 0008 | 0010 | 0012 | 0018 | 0020  | 0030                                 | 0040 | 0056 | 0069 |
|--------------------------------|------------------------|---|------|------|------|------|------|------|------|-------|--------------------------------------|------|------|------|
|                                | Single-Phase CIMR-VABA | 0001                                    | 0002 | 0003 | 0006 | -    | 0010 | 0012 | -    | 0018* | -                                    | -    | -    | -    |
| Max. Applicable Motor Capacity | Normal Duty            | 0.2                                     | 0.4  | 0.75 | 1.1  | 1.5  | 2.2  | 3    | 3.7  | 5.5   | 7.5                                  | 11   | 15   | 18.5 |
|                                | Heavy Duty             | 0.1                                     | 0.2  | 0.4  | 0.75 | 1.1  | 1.5  | 2.2  | 3    | 3.7   | 5.5                                  | 7.5  | 11   | 15   |
| Open-Chassis                   |                        | Standard: IP20                          |      |      |      |      |      |      |      |       | IP00 (without top and bottom covers) |      |      |      |
| Enclosure Panel [NEMA Type 1]  |                        | Option available (IP20 with NEMA 1 kit) |      |      |      |      |      |      |      |       | Standard                             |      |      |      |

### 400 V Class (Three-Phase)

| Model                          | CIMR-VA4A   | 0001                                    | 0002 | 0004 | 0005 | 0007 | 0009 | 0011 | 0018                                 | 0023 | 0031 | 0038 |
|--------------------------------|-------------|---|------|------|------|------|------|------|--------------------------------------|------|------|------|
| Max. Applicable Motor Capacity | Normal Duty | 0.4                                     | 0.75 | 1.5  | 2.2  | 3    | 3.7  | 5.5  | 7.5                                  | 11   | 15   | 18.5 |
|                                | Heavy Duty  | 0.2                                     | 0.4  | 0.75 | 1.5  | 2.2  | 3    | 3.7  | 5.5                                  | 7.5  | 11   | 15   |
| Open-Chassis                   |             | Standard: IP20                          |      |      |      |      |      |      | IP00 (without top and bottom covers) |      |      |      |
| Enclosure Panel [NEMA Type 1]  |             | Option available (IP20 with NEMA 1 kit) |      |      |      |      |      |      | Standard                             |      |      |      |

\*: CIMR-VABA0018 does not have a Normal Duty rating

### Open-Chassis [ IP20 ]

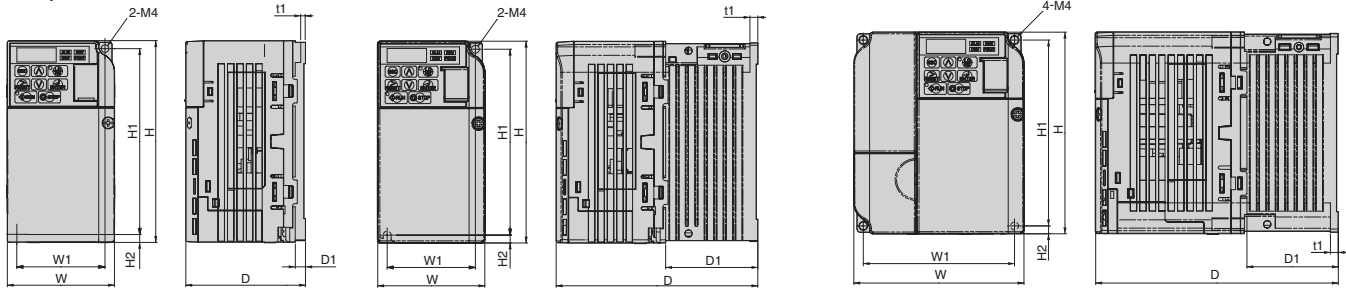

Figure 1

Figure 2

Figure 3

| Voltage Class              | Model CIMR- VA | Figure | Dimensions (mm) |     |       |     |     |    |      |     |            | Weight (kg) | Cooling     |
|----------------------------|----------------|--------|-----------------|-----|-------|-----|-----|----|------|-----|------------|-------------|-------------|
|                            |                |        | W               | H   | D     | W1  | H1  | H2 | D1   | t1  | Mtg. Holes |             |             |
| 200 V Class (Three-Phase)  | 2A0001B        | 1      | 68              | 128 | 76    | 56  | 118 | 5  | 6.5  | 3   | M4         | 0.6         | Self-cooled |
|                            | 2A0002B        |        | 68              | 128 | 76    | 56  | 118 | 5  | 6.5  | 3   | M4         | 0.6         |             |
|                            | 2A0004B        | 2      | 68              | 128 | 108   | 56  | 118 | 5  | 38.5 | 5   | M4         | 0.9         | Fan cooled  |
|                            | 2A0006B        |        | 68              | 128 | 128   | 56  | 118 | 5  | 58.5 | 5   | M4         | 1.1         |             |
|                            | 2A0008B        | 3      | 108             | 128 | 129   | 96  | 118 | 5  | 58   | 5   | M4         | 1.7         |             |
|                            | 2A0010B        |        | 108             | 128 | 129   | 96  | 118 | 5  | 58   | 5   | M4         | 1.7         |             |
|                            | 2A0012B        |        | 108             | 128 | 137.5 | 96  | 118 | 5  | 58   | 5   | M4         | 1.7         |             |
|                            | 2A0018B        |        | 140             | 128 | 143   | 128 | 118 | 5  | 65   | 5   | M4         | 2.4         |             |
| 2A0020B                    | 140            | 128    | 143             | 128 | 118   | 5   | 65  | 5  | M4   | 2.4 |            |             |             |
| 200 V Class (Single-Phase) | BA0001B        | 1      | 68              | 128 | 76    | 56  | 118 | 5  | 6.5  | 3   | M4         | 0.6         | Self-cooled |
|                            | BA0002B        |        | 68              | 128 | 76    | 56  | 118 | 5  | 6.5  | 3   | M4         | 0.6         |             |
|                            | BA0003B        | 2      | 68              | 128 | 118   | 56  | 118 | 5  | 38.5 | 5   | M4         | 1           | Fan cooled  |
|                            | BA0006B        | 3      | 108             | 128 | 137.5 | 96  | 118 | 5  | 58   | 5   | M4         | 1.7         |             |
|                            | BA0010B        |        | 108             | 128 | 154   | 96  | 118 | 5  | 58   | 5   | M4         | 1.8         |             |
|                            | BA0012B        |        | 140             | 128 | 163   | 128 | 118 | 5  | 65   | 5   | M4         | 2.4         |             |
|                            | BA0018B        | 170    | 128             | 180 | 158   | 118 | 5   | 65 | 5    | M4  | 3          |             |             |
| 400 V Class (Three-Phase)  | 4A0001B        | 3      | 108             | 128 | 81    | 96  | 118 | 5  | 10   | 5   | M4         | 1           | Self-cooled |
|                            | 4A0002B        |        | 108             | 128 | 99    | 96  | 118 | 5  | 28   | 5   | M4         | 1.2         |             |
|                            | 4A0004B        |        | 108             | 128 | 137.5 | 96  | 118 | 5  | 58   | 5   | M4         | 1.7         |             |
|                            | 4A0005B        |        | 108             | 128 | 154   | 96  | 118 | 5  | 58   | 5   | M4         | 1.7         | Fan cooled  |
|                            | 4A0007B        |        | 108             | 128 | 154   | 96  | 118 | 5  | 58   | 5   | M4         | 1.7         |             |
|                            | 4A0009B        |        | 108             | 128 | 154   | 96  | 118 | 5  | 58   | 5   | M4         | 1.7         |             |
|                            | 4A0011B        |        | 140             | 128 | 143   | 128 | 118 | 5  | 65   | 5   | M4         | 2.4         |             |



■ Enclosure Panel [NEMA Type 1]

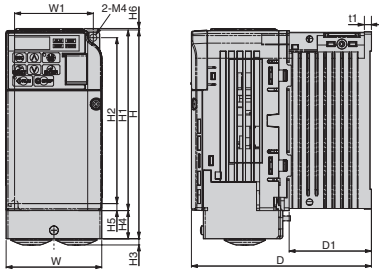

Figure 1

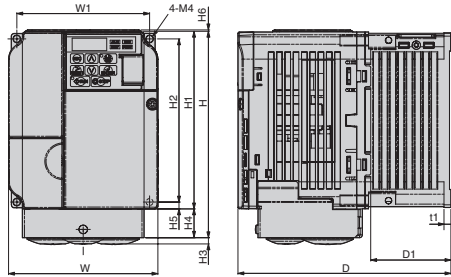

Figure 2

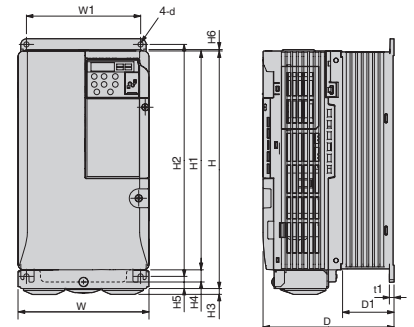

Figure 3

| Voltage Class              | Model CIMR-VA | Figure | Dimensions (mm) |     |     |     |       |    |    |      |     |    |     |     |     | Weight (kg)              | NEMA 1 Kit Code No. (Model) | Cooling     |
|----------------------------|---------------|--------|-----------------|-----|-----|-----|-------|----|----|------|-----|----|-----|-----|-----|--------------------------|-----------------------------|-------------|
|                            |               |        | W1              | H2  | W   | H1  | D     | t1 | H5 | D1   | H   | H4 | H3  | H6  | d   |                          |                             |             |
| 200 V Class (Three-Phase)  | 2A0001B       | 1      | 56              | 118 | 68  | 128 | 76    | 3  | 5  | 6.5  | 148 | 20 | 5   | 1.5 | M4  | 0.8                      | 100-036-378 (EZZ020564A)    | Self cooled |
|                            | 2A0002B       |        | 56              | 118 | 68  | 128 | 76    | 3  | 5  | 6.5  | 148 | 20 | 5   | 1.5 | M4  | 0.8                      |                             |             |
|                            | 2A0004B       |        | 56              | 118 | 68  | 128 | 108   | 5  | 5  | 38.5 | 148 | 20 | 5   | 1.5 | M4  | 1.1                      |                             |             |
|                            | 2A0006B       |        | 56              | 118 | 68  | 128 | 128   | 5  | 5  | 58.5 | 148 | 20 | 5   | 1.5 | M4  | 1.3                      |                             |             |
|                            | 2A0008B       | 2      | 96              | 118 | 108 | 128 | 129   | 5  | 5  | 58   | 149 | 21 | 5   | 1.5 | M4  | 1.9                      | 100-036-380 (EZZ020564G)    | Fan cooled  |
|                            | 2A0010B       |        | 96              | 118 | 108 | 128 | 129   | 5  | 5  | 58   | 149 | 21 | 5   | 1.5 | M4  | 1.9                      |                             |             |
|                            | 2A0012B       |        | 96              | 118 | 108 | 128 | 137.5 | 5  | 5  | 58   | 149 | 21 | 5   | 1.5 | M4  | 1.9                      |                             |             |
|                            | 2A0018B       |        | 128             | 118 | 140 | 128 | 143   | 5  | 5  | 65   | 149 | 21 | 5   | 5   | M4  | 2.6                      |                             |             |
|                            | 2A0020B       | 3      | 128             | 118 | 140 | 128 | 143   | 5  | 5  | 65   | 149 | 21 | 5   | 5   | M4  | 2.6                      | Not required (Standard)     |             |
|                            | 2A0030F       |        | 122             | 248 | 140 | 234 | 140   | 5  | 13 | 55   | 254 | 13 | 6   | 1.5 | M5  | 3.8                      |                             |             |
|                            | 2A0040F       |        | 122             | 248 | 140 | 234 | 140   | 5  | 13 | 55   | 254 | 13 | 6   | 1.5 | M5  | 3.8                      |                             |             |
|                            | 2A0056F       |        | 160             | 284 | 180 | 270 | 163   | 5  | 13 | 75   | 290 | 15 | 6   | 1.5 | M5  | 5.5                      |                             |             |
| 2A0069F                    |               | 192    | 336             | 220 | 320 | 187 | 5     | 22 | 78 | 350  | 15  | 7  | 1.5 | M6  | 9.2 |                          |                             |             |
| 200 V Class (Single-Phase) | BA0001B       | 1      | 56              | 118 | 68  | 128 | 76    | 3  | 5  | 6.5  | 148 | 20 | 5   | 1.5 | M4  | 0.8                      | 100-036-378 (EZZ020564A)    | Self cooled |
|                            | BA0002B       |        | 56              | 118 | 68  | 128 | 76    | 3  | 5  | 6.5  | 148 | 20 | 5   | 1.5 | M4  | 0.8                      |                             |             |
|                            | BA0003B       |        | 56              | 118 | 68  | 128 | 118   | 5  | 5  | 38.5 | 148 | 20 | 5   | 1.5 | M4  | 1.2                      |                             |             |
|                            | BA0006B       | 2      | 96              | 118 | 108 | 128 | 137.5 | 5  | 5  | 58   | 149 | 21 | 5   | 1.5 | M4  | 1.9                      | 100-036-381 (EZZ020564C)    | Fan cooled  |
|                            | BA0010B       |        | 96              | 118 | 108 | 128 | 154   | 5  | 5  | 58   | 149 | 21 | 5   | 1.5 | M4  | 2                        |                             |             |
|                            | BA0012B       |        | 128             | 118 | 140 | 128 | 163   | 5  | 5  | 65   | 149 | 21 | 5   | 5   | M4  | 2.6                      |                             |             |
| BA0018B                    |               | 158    | 118             | 170 | 128 | 180 | 5     | 5  | 65 | 166  | 38  | 5  | 5   | M4  | 3.3 | 100-036-386 (EZZ020564F) |                             |             |
| 400 V Class (Three-Phase)  | 4A0001B       | 2      | 96              | 118 | 108 | 128 | 81    | 5  | 5  | 10   | 149 | 21 | 5   | 1.5 | M4  | 1.2                      | 100-036-380 (EZZ020564G)    | Self cooled |
|                            | 4A0002B       |        | 96              | 118 | 108 | 128 | 99    | 5  | 5  | 28   | 149 | 21 | 5   | 1.5 | M4  | 1.4                      |                             |             |
|                            | 4A0004B       |        | 96              | 118 | 108 | 128 | 137.5 | 5  | 5  | 58   | 149 | 21 | 5   | 1.5 | M4  | 1.9                      |                             |             |
|                            | 4A0005B       |        | 96              | 118 | 108 | 128 | 154   | 5  | 5  | 58   | 149 | 21 | 5   | 1.5 | M4  | 1.9                      |                             |             |
|                            | 4A0007B       |        | 96              | 118 | 108 | 128 | 154   | 5  | 5  | 58   | 149 | 21 | 5   | 1.5 | M4  | 1.9                      |                             |             |
|                            | 4A0009B       |        | 96              | 118 | 108 | 128 | 154   | 5  | 5  | 58   | 149 | 21 | 5   | 1.5 | M4  | 1.9                      |                             |             |
|                            | 4A0011B       | 3      | 128             | 118 | 140 | 128 | 143   | 5  | 5  | 65   | 149 | 21 | 5   | 5   | M4  | 2.6                      | 100-036-384 (EZZ020564H)    | Fan cooled  |
|                            | 4A0018F       |        | 122             | 248 | 140 | 234 | 140   | 5  | 13 | 55   | 254 | 13 | 6   | 1.5 | M5  | 3.8                      |                             |             |
|                            | 4A0023F       |        | 122             | 248 | 140 | 234 | 140   | 5  | 13 | 55   | 254 | 13 | 6   | 1.5 | M5  | 3.8                      |                             |             |
|                            | 4A0031F       |        | 160             | 284 | 180 | 270 | 143   | 5  | 13 | 55   | 290 | 15 | 6   | 1.5 | M5  | 5.2                      |                             |             |
| 4A0038F                    |               | 160    | 284             | 180 | 270 | 163 | 5     | 13 | 75 | 290  | 15  | 6  | 1.5 | M5  | 5.5 | Not required (Standard)  |                             |             |

Note: For the models shown in Figures 1 and 2, the NEMA 1 kit (option) is required.  
The dimensions in the above table are intended for the IP20/Open Chassis enclosure with the NEMA 1 kit.



# Fully-Enclosed Design

The Open Chassis type drive can be installed in a fully-enclosed panel.

The heatsink can be mounted outside the enclosure panel, thus reducing the amount of heat inside the panel and allowing for a more compact set up. Proper installation requires an understanding of the temperature at each point within the enclosure panel as shown below.

Be sure to leave enough clearance during installation for ventilation and proper cooling as well as access to wiring for maintenance.

## Cooling Design for Fully-Closed Enclosure Panel

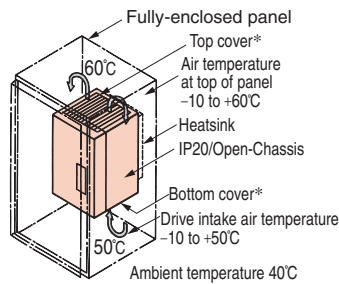

## Mounting the External Heatsink

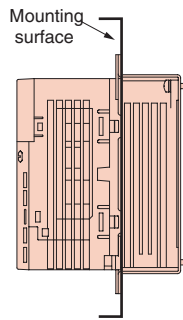

## Ensuring Ventilation

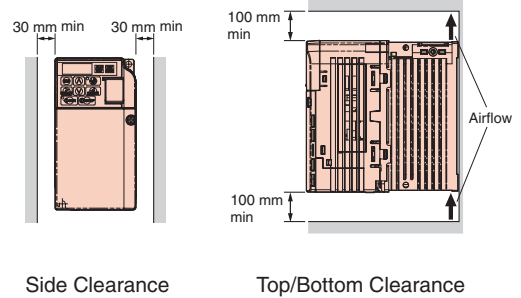

Note: A separate mounting bracket option is required to install the heatsink outside the enclosure. Refer to the following page.

\*: The Enclosure Panel type models (CIMR-VA2A0030 to 0069, CIMR-VA4A0018 to 0038) can be installed with the top and bottom covers removed.

## Drive Watts Loss Data

### Normal Duty Ratings

| Voltage Class              | Model Number |                      | 0001            | 0002 | 0004 | 0006 | 0008 | 0010 | 0012 | 0018 | 0020 | 0030  | 0040  | 0056  | 0069  |       |       |
|----------------------------|--------------|----------------------|-----------------|------|------|------|------|------|------|------|------|-------|-------|-------|-------|-------|-------|
| 200 V Class (Three-Phase)  | CIMR-VA2A    | Rated Output Current | A               | 1.2  | 1.9  | 3.5  | 6    | 8    | 9.6  | 12   | 17.5 | 19.6  | 30    | 40    | 56    | 69    |       |
|                            |              | Heat Loss            | Heatsink        | W    | 5    | 7.6  | 15.8 | 27.5 | 44.6 | 51.7 | 61.3 | 89.8  | 98.7  | 246.4 | 266.7 | 357.9 | 461.7 |
|                            |              |                      | Internal        | W    | 8    | 9.5  | 13.6 | 17.2 | 24   | 25.8 | 30.4 | 44.1  | 46.3  | 88.9  | 112.8 | 151.8 | 184.5 |
|                            |              |                      | Total Heat Loss | W    | 13   | 17.1 | 29.4 | 44.7 | 68.6 | 77.5 | 91.7 | 133.9 | 145   | 335.3 | 379.5 | 509.7 | 646.2 |
| 200 V Class (Single-Phase) | CIMR-VABA    | Rated Output Current | A               | 1.2  | 1.9  | 3.3  | 6    | -    | 9.6  | 12   | -    | -     | -     | -     | -     | -     |       |
|                            |              | Heat Loss            | Heatsink        | W    | 5    | 7.6  | 14.6 | 30.1 | -    | 51.7 | 61.3 | -     | -     | -     | -     | -     | -     |
|                            |              |                      | Internal        | W    | 8.5  | 9.7  | 14.4 | 19.4 | -    | 29.8 | 37.1 | -     | -     | -     | -     | -     | -     |
|                            |              |                      | Total Heat Loss | W    | 13.5 | 17.3 | 29   | 49.5 | -    | 81.5 | 98.4 | -     | -     | -     | -     | -     | -     |
| 400 V Class (Three-Phase)  | CIMR-VA4A    | Rated Output Current | A               | 1.2  | 2.1  | 4.1  | 5.4  | -    | 6.9  | 8.8  | -    | 11.1  | 17.5  | 23    | 31    | 38    |       |
|                            |              | Heat Loss            | Heatsink        | W    | 10   | 18.5 | 30.5 | 44.5 | -    | 58.5 | 63.7 | -     | 81.7  | 181.2 | 213.4 | 287.5 | 319.2 |
|                            |              |                      | Internal        | W    | 9.6  | 13.9 | 16.8 | 21.8 | -    | 28.5 | 31.4 | -     | 46    | 80.1  | 107.7 | 146.1 | 155.8 |
|                            |              |                      | Total Heat Loss | W    | 19.6 | 32.4 | 47.3 | 66.3 | -    | 87   | 95.1 | -     | 127.7 | 261.3 | 321.1 | 433.6 | 475   |

Note: Heat loss data based on carrier frequency of 2 kHz (default).

### Heavy Duty Ratings

| Voltage Class              | Model Number |                      | 0001*1          | 0002*1 | 0004*1 | 0006*1 | 0008*1 | 0010*2 | 0012*2 | 0018*2 | 0020*2 | 0030*2 | 0040*2 | 0056*2 | 0069*2 |       |       |
|----------------------------|--------------|----------------------|-----------------|--------|--------|--------|--------|--------|--------|--------|--------|--------|--------|--------|--------|-------|-------|
| 200 V Class (Three-Phase)  | CIMR-VA2A    | Rated Output Current | A               | 0.8    | 1.6    | 3      | 5      | 6.9    | 8      | 11     | 14     | 17.5   | 25     | 33     | 47     | 60    |       |
|                            |              | Heat Loss            | Heatsink        | W      | 4.3    | 7.9    | 16.1   | 27.4   | 48.7   | 54.8   | 70.7   | 92.6   | 110.5  | 231.5  | 239.5  | 347.6 | 437.7 |
|                            |              |                      | Internal        | W      | 7.3    | 8.8    | 11.5   | 15.9   | 22.2   | 23.8   | 30     | 38.8   | 43.3   | 72.2   | 81.8   | 117.6 | 151.4 |
|                            |              |                      | Total Heat Loss | W      | 11.6   | 16.7   | 27.6   | 43.3   | 70.9   | 78.6   | 100.7  | 131.4  | 153.8  | 303.7  | 321.3  | 465.2 | 589.1 |
| 200 V Class (Single-Phase) | CIMR-VABA    | Rated Output Current | A               | 0.8    | 1.6    | 3      | 5      | -      | 8      | 11     | -      | 17.5   | -      | -      | -      | -     |       |
|                            |              | Heat Loss            | Heatsink        | W      | 4.3    | 7.9    | 16.1   | 33.7   | -      | 54.8   | 70.7   | -      | 110.5  | -      | -      | -     | -     |
|                            |              |                      | Internal        | W      | 7.4    | 8.9    | 11.5   | 16.8   | -      | 25.9   | 34.1   | -      | 51.4   | -      | -      | -     | -     |
|                            |              |                      | Total Heat Loss | W      | 11.7   | 16.8   | 27.6   | 50.5   | -      | 80.7   | 104.8  | -      | 161.9  | -      | -      | -     | -     |
| 400 V Class (Three-Phase)  | CIMR-VA4A    | Rated Output Current | A               | 1.2    | 1.8    | 3.4    | 4.8    | -      | 5.5    | 7.2    | -      | 9.2    | 14.8   | 18     | 24     | 31    |       |
|                            |              | Heat Loss            | Heatsink        | W      | 19.2   | 28.9   | 42.3   | 70.7   | -      | 81     | 84.6   | -      | 107.2  | 166    | 207.1  | 266.9 | 319.1 |
|                            |              |                      | Internal        | W      | 11.4   | 14.9   | 17.9   | 26.2   | -      | 30.7   | 32.9   | -      | 41.5   | 62.7   | 78.1   | 105.9 | 126.6 |
|                            |              |                      | Total Heat Loss | W      | 30.6   | 43.8   | 60.2   | 96.9   | -      | 111.7  | 117.5  | -      | 148.7  | 228.7  | 285.2  | 372.8 | 445.7 |

\*1: Heat loss data based on carrier frequency of 10 kHz (default).

\*2: Heat loss data based on carrier frequency of 8 kHz (default).

## Attachment for External Heatsink

Additional attachments required for installation.  
Final dimensions are taller than drive height.

### Dimensions (Heatsink for a 200 V 0.4 kW drive)

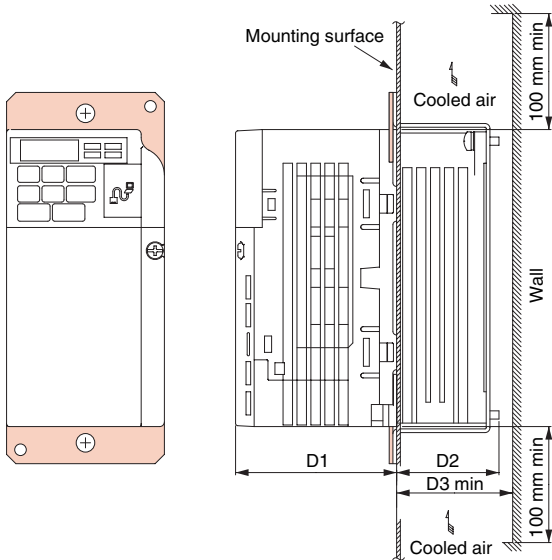

Note: The Enclosure Panel type models (CIMR-VA2A0030 to 0069, CIMR-VA4A0018 to 0038) can be installed with the top and bottom covers removed.

| Model<br>CIMR-VA | Dimensions (mm) |      |    | Code No.<br>(Model)      |
|------------------|-----------------|------|----|--------------------------|
|                  | D1              | D2   | D3 |                          |
| 2A0001           | 69.5            | 12   | 30 | 100-034-075 (EZZ020568A) |
| 2A0002           |                 |      |    |                          |
| 2A0004           |                 |      |    |                          |
| 2A0006           | 69.5            | 42   | 50 | 100-034-076 (EZZ020568B) |
| 2A0008           |                 |      |    |                          |
| 2A0010           | 71              | 58   | 70 | 100-034-079 (EZZ020568D) |
| 2A0012           |                 |      |    |                          |
| 2A0018           |                 |      |    |                          |
| 2A0020           | 78              | 65   | 70 | 100-034-080 (EZZ020568E) |
| 2A0030           |                 |      |    |                          |
| 2A0040           | 86.6            | 53.4 | 60 | 100-036-300 (EZZ020568H) |
| 2A0056           |                 |      |    |                          |
| 2A0069           |                 |      |    |                          |
| 2A0069           | 110.6           | 76.4 | 85 | 100-036-302 (EZZ020568K) |
| BA0001           | 69.5            | 12   | 30 | 100-034-075 (EZZ020568A) |
| BA0002           |                 |      |    |                          |
| BA0003           |                 |      |    |                          |
| BA0006           | 79.5            | 58   | 70 | 100-036-418 (EZZ020568C) |
| BA0010           |                 |      |    |                          |
| BA0012           | 96              | 58   | 70 | 100-034-079 (EZZ020568D) |
| BA0018           |                 |      |    |                          |
| BA0018           |                 |      |    |                          |
| BA0018           | 115             | 65   | 70 | 100-036-357 (EZZ020568F) |
| 4A0001           | 71              | 13.5 | 30 | 100-034-078 (EZZ020568L) |
| 4A0002           |                 |      |    |                          |
| 4A0004           |                 |      |    |                          |
| 4A0005           | 79.5            | 58   | 70 | 100-036-418 (EZZ020568C) |
| 4A0007           |                 |      |    |                          |
| 4A0009           |                 |      |    |                          |
| 4A0011           | 96              | 58   | 70 | 100-034-079 (EZZ020568D) |
| 4A0018           |                 |      |    |                          |
| 4A0018           |                 |      |    |                          |
| 4A0023           | 86.6            | 53.4 | 60 | 100-036-300 (EZZ020568H) |
| 4A0031           |                 |      |    |                          |
| 4A0038           |                 |      |    |                          |
| 4A0038           | 89.6            | 53.4 | 60 | 100-036-301 (EZZ020568J) |
|                  |                 | 73.4 | 80 |                          |

DIN rail attachment available for quick mounting and disassembly.

## DIN Rail Attachment

The attachment is applicable to models with dimensions of 170 mm (W) and 128 mm (H) max.  
Not for use with finless-type models (models without a heatsink).

### Dimension (Heatsink for a 200 V 0.4 kW drive)

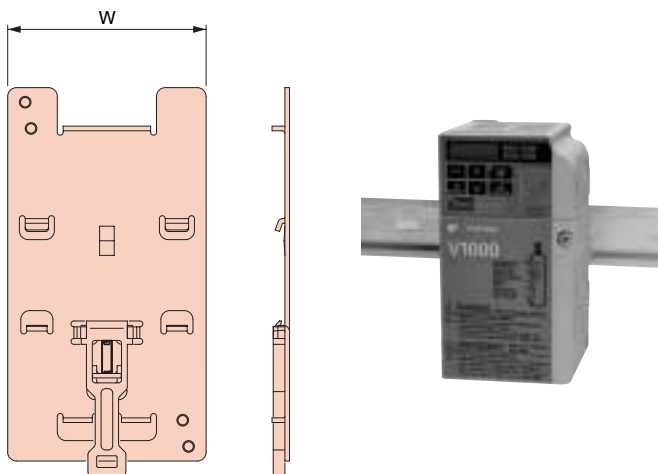

| Model<br>CIMR-VA | Width (mm) | Code No.  |
|------------------|------------|-----------|
| 2A0001           | 68         | EZZ08122A |
| 2A0002           |            |           |
| 2A0004           |            |           |
| 2A0006           | 108        | EZZ08122B |
| 2A0008           |            |           |
| 2A0010           |            |           |
| 2A0012           | 140        | EZZ08122C |
| 2A0018           |            |           |
| 2A0020           |            |           |
| BA0001           | 68         | EZZ08122A |
| BA0002           |            |           |
| BA0003           |            |           |
| BA0006           | 108        | EZZ08122B |
| BA0010           |            |           |
| BA0012           |            |           |
| BA0018           | 170        | EZZ08122D |
| BA0018           |            |           |
| BA0018           |            |           |
| 4A0001           | 108        | EZZ08122B |
| 4A0002           |            |           |
| 4A0004           |            |           |
| 4A0005           |            |           |
| 4A0007           |            |           |
| 4A0009           |            |           |
| 4A0011           |            |           |
| 4A0011           | 140        | EZZ08122C |
|                  |            |           |



# Peripheral Devices and Options

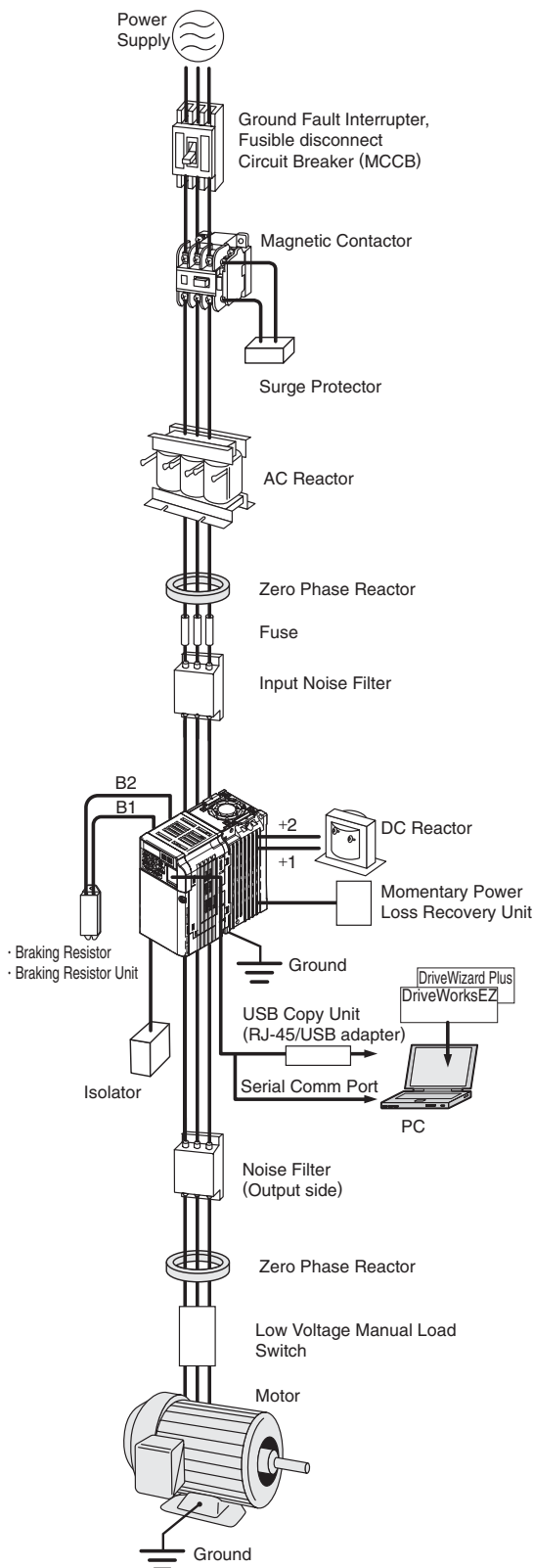

| Name                                      | Purpose   | Model, Manufacturer   | Page     |
|---|---|---|----------|
| Ground Fault Interrupter (GFI)            | Always install a GFI on the power-supply side to protect the power supply system and to prevent an overload at the occurrence of short-circuit, and to protect the drive from ground faults that could result in electric shock or fire. Note: When a GFI is installed for the upper power supply system, an MCCB can be used instead of a GFI.<br><br>(Choose a GFI designed to minimize harmonics specifically for AC drives. Use one GFI per drive, each with a current rating of at least 30 mA.) | Recommended: NV series by Mitsubishi Electric   | p.30     |
| Circuit Breaker                           | Always install a circuit breaker on the power-supply side to protect the power supply system and to prevent an overload at the occurrence of a short-circuit.   | Recommended: NF series by Mitsubishi Electric   | p.30     |
| Magnetic Contactor                        | Interrupts the power supply to the drive. In addition to protecting drive circuitry, a magnetic contactor also prevents damage to a braking resistor if used.   | Recommended: SC series by Fuji Electric   | p.31     |
| Surge Protector                           | Absorbs the voltage surge from switching of electro-magnetic contactors and control relays. Install a surge protector to the magnetic contactors and control relays as well as magnetic valves and magnetic braking coil.   | DCR2 series RFN series by Nippon Chemi-Con Corporation  | p.31     |
| DC Reactor                                | Used for harmonic current suppression and total improving power factor.   | UZDA series   | p.32, 33 |
| AC Reactor                                | Should be used if the power supply capacity is larger than 600 kVA.   | UZBA series   | p.34, 35 |
| Zero Phase Reactor                        | Reduces noise from the line that enters into the drive input power system. Should be installed as close as possible to the drive. Can be used on both the input and output sides.   | F6045GB F11080GB by Hitachi Metals, Ltd.  | p.36     |
| Fuse / Fuse Holder                        | Protects internal circuitry in the event of component failure. Fuse should be connected to the input terminal of the drive. Note: Refer to the instruction manual for information on UL approval.   | CR6L series CMS series by Fuji Electric   | p.37     |
| Capacitor-type Noise Filter               | Reduces noise from the line that enters into the drive input power system. The noise filter can be used in combination with a zero-phase reactor. Note: Available for drive input only. Do not connect the noise filter to the output terminals.  | 3XYG 1003 by Okaya Electric Industries  | p.37     |
| Input Noise Filter                        | Reduces noise from the line that enters into the drive input power system. Should be installed as close as possible to the drive.   | LNFD series LNFB series FN series For CE Marking (EMC Directive) compliant models, refer to V1000 Technical Manual. | p.38, 39 |
| Output Noise Filter                       | Reduces noise from the line that enters into the drive input power system. Should be installed as close as possible to the drive.   | LF series by NEC TOKIN Corporation  | p.40     |
| Isolator                                  | Isolates the drive I/O signal, and is effective in reducing inductive noise.  | DGP2 series   | p.41     |
| Braking Resistor                          | Used to shorten the deceleration time by dissipating regenerative energy through a resistor. (3% ED)  | ERF-150WJ series CF120-B579 series  | p.42, 43 |
| Braking Resistor Unit                     | Used to shorten the deceleration time by dissipating regenerative energy through a resistor. A thermal overload relay is built in. (10% ED)   | LKEB series   | p.42, 43 |
| 24 V Power Supply                         | Provides power supply for the control circuit and option boards. Note: Parameter settings cannot be changed when the drive is operating solely from this power supply.  | PS-V10S PS-V10M   | p.44     |
| USB Copy Unit (RJ-45/USB compatible plug) | · Adapter for connecting the drive to the USB port of a PC.<br>· Can copy parameter settings to be later transferred to another drive.  | JVOP-181  | p.45     |

| Name  | Purpose   | Model, Manufacturer  | Page           |      |
|---|---|--|----------------|------|
| Support Tools<br>(DriveWizard) Cable                        | Connects the drive to a PC for use with DriveWizard.  | WV103  | p.45           |      |
| Remote Digital Operator                                     | Allows for remote operation.<br>Includes a Copy function for saving drive settings.   | LCD: JVOP-180<br>LED: JVOP-182   | p.46           |      |
| Operator Extension Cable                                    | Cable for connecting the remote digital operator.   | WV001: 1 m<br>WV003: 3 m   |                |      |
| Communi-<br>cation<br>Interface<br>Unit                     | Allows control of the drive via a fieldbus network.   | MECHATROLINK-II  | SI-T3/V        | p.47 |
|   |   | MECHATROLINK-III   | Available soon |      |
|   |   | CC-Link  | SI-C3/V        |      |
|   |   | DeviceNet  | SI-N3/V        |      |
|   |   | CompoNet   | SI-M3/V        |      |
|   |   | PROFIBUS-DP  | SI-P3/V        |      |
|   |   | CANopen  | SI-S3/V        |      |
| Momentary Power Loss<br>Recovery Unit                       | Ensures continued drive operation for a power loss of up to 2 s.  | P0010 Type (200 V class)<br>P0020 Type (400 V class)                       | p.48           |      |
| Frequency Meter, Current Meter                              | Allows the user to set and monitor the frequency, current, and voltage using an external device.  | DCF-6A   | p.48           |      |
| Frequency setting<br>Potentiometer (2 k $\Omega$ )          |   | RH000739   |                |      |
| Frequency Meter Adjusting<br>Potentiometer (20 k $\Omega$ ) |   | RH000850   |                |      |
| Control Dial for Frequency<br>Setting Potentiometer         |   | CM-3S  | p.49           |      |
| Output Voltage Meter  |   | SCF-12NH   |                |      |
| Potential Transformer                                       |   | UPN-B  |                |      |
| NEMA 1 Kit  | Turns an IP20 open-chassis design into a NEMA 1 compliant enclosure panel.  | —  | p.25           |      |
| Attachment for External<br>Heatsink                         | Mechanical kit to install the drive with the heatsink out of the cabinet.<br>Note: Current derating must be considered in some instances. | —  | p.27           |      |
| DIN Rail Attachment   | Allows mounting the drive on a DIN rail.<br>Installs to the rear of the drive unit.   | —  |                |      |
| Low Voltage Manual Load<br>Switch                           | Prevents shock from the voltage created on the terminals board from a coasting synchronous motor.   | Recommended:<br>AICUT, LB<br>series by AICHI<br>ELECTRIC<br>WORKS CO.,Ltd. | —              |      |

Note: Contact the manufacturer in question for availability and specifications of non-Yaskawa products.



# Peripheral Devices and Options (continued)

## Ground Fault Interrupter, Circuit Breaker

Base device selection on motor capacity.



Ground Fault Interrupter  
[Mitsubishi Electric]



Circuit Breaker  
[Mitsubishi Electric]

### Three-Phase 200 V Class

| Motor Capacity (kW) | Ground Fault Interrupter |                   |                                   |                |                   |                                   | Circuit Breaker   |                   |                                   |                |                   |                                   |
|---------------------|--------------------------|-------------------|-----------------------------------|----------------|-------------------|-----------------------------------|-------------------|-------------------|-----------------------------------|----------------|-------------------|-----------------------------------|
|                     | Without Reactor*1        |                   |                                   | With Reactor*2 |                   |                                   | Without Reactor*1 |                   |                                   | With Reactor*2 |                   |                                   |
|                     | Model                    | Rated Current (A) | Interrupt Capacity (kA) Icu/Ics*3 | Model          | Rated Current (A) | Interrupt Capacity (kA) Icu/Ics*3 | Model             | Rated Current (A) | Interrupt Capacity (kA) Icu/Ics*3 | Model          | Rated Current (A) | Interrupt Capacity (kA) Icu/Ics*3 |
| 0.1                 | NV32-SV                  | 5                 | 10/10                             | NV32-SV        | 5                 | 10/10                             | NF32-SV           | 5                 | 7.5/7.5                           | NF32-SV        | 5                 | 7.5/7.5                           |
| 0.2                 | NV32-SV                  | 5                 | 10/10                             | NV32-SV        | 5                 | 10/10                             | NF32-SV           | 5                 | 7.5/7.5                           | NF32-SV        | 5                 | 7.5/7.5                           |
| 0.4                 | NV32-SV                  | 5                 | 10/10                             | NV32-SV        | 5                 | 10/10                             | NF32-SV           | 5                 | 7.5/7.5                           | NF32-SV        | 5                 | 7.5/7.5                           |
| 0.75                | NV32-SV                  | 10                | 10/10                             | NV32-SV        | 10                | 10/10                             | NF32-SV           | 10                | 7.5/7.5                           | NF32-SV        | 10                | 7.5/7.5                           |
| 1.5                 | NV32-SV                  | 15                | 10/10                             | NV32-SV        | 10                | 10/10                             | NF32-SV           | 15                | 7.5/7.5                           | NF32-SV        | 10                | 7.5/7.5                           |
| 2.2                 | NV32-SV                  | 20                | 10/10                             | NV32-SV        | 15                | 10/10                             | NF32-SV           | 20                | 7.5/7.5                           | NF32-SV        | 15                | 7.5/7.5                           |
| 3.7                 | NV32-SV                  | 30                | 10/10                             | NV32-SV        | 20                | 10/10                             | NF32-SV           | 30                | 7.5/7.5                           | NF32-SV        | 20                | 7.5/7.5                           |
| 5.5                 | NV63-SV                  | 50                | 15/15                             | NV63-SV        | 40                | 15/15                             | NF63-SV           | 50                | 15/15                             | NF63-SV        | 40                | 15/15                             |
| 7.5                 | NV125-SV                 | 60                | 50/50                             | NV63-SV        | 50                | 15/15                             | NF125-SV          | 60                | 50/50                             | NF63-SV        | 50                | 15/15                             |
| 11                  | NV125-SV                 | 75                | 50/50                             | NV125-SV       | 75                | 50/50                             | NF125-SV          | 75                | 50/50                             | NF125-SV       | 75                | 50/50                             |
| 15                  | NV250-SV                 | 125               | 85/85                             | NV125-SV       | 100               | 50/50                             | NF250-SV          | 125               | 85/85                             | NF125-SV       | 100               | 50/50                             |
| 18.5                | NV250-SV                 | 150               | 85/85                             | NV250-SV       | 125               | 85/85                             | NF250-SV          | 150               | 85/85                             | NF250-SV       | 125               | 85/85                             |

### Single-Phase 200 V Class

| Motor Capacity (kW) | Ground Fault Interrupter |                   |                                   |                |                   |                                   | Circuit Breaker   |                   |                                   |                |                   |                                   |
|---------------------|--------------------------|-------------------|-----------------------------------|----------------|-------------------|-----------------------------------|-------------------|-------------------|-----------------------------------|----------------|-------------------|-----------------------------------|
|                     | Without Reactor*1        |                   |                                   | With Reactor*2 |                   |                                   | Without Reactor*1 |                   |                                   | With Reactor*2 |                   |                                   |
|                     | Model                    | Rated Current (A) | Interrupt Capacity (kA) Icu/Ics*3 | Model          | Rated Current (A) | Interrupt Capacity (kA) Icu/Ics*3 | Model             | Rated Current (A) | Interrupt Capacity (kA) Icu/Ics*3 | Model          | Rated Current (A) | Interrupt Capacity (kA) Icu/Ics*3 |
| 0.1                 | NV32-SV                  | 5                 | 10/10                             | NV32-SV        | 5                 | 10/10                             | NF32-SV           | 5                 | 7.5/7.5                           | NF32-SV        | 5                 | 7.5/7.5                           |
| 0.2                 | NV32-SV                  | 5                 | 10/10                             | NV32-SV        | 5                 | 10/10                             | NF32-SV           | 5                 | 7.5/7.5                           | NF32-SV        | 5                 | 7.5/7.5                           |
| 0.4                 | NV32-SV                  | 10                | 10/10                             | NV32-SV        | 10                | 10/10                             | NF32-SV           | 10                | 7.5/7.5                           | NF32-SV        | 10                | 7.5/7.5                           |
| 0.75                | NV32-SV                  | 20                | 10/10                             | NV32-SV        | 15                | 10/10                             | NF32-SV           | 20                | 7.5/7.5                           | NF32-SV        | 15                | 7.5/7.5                           |
| 1.5                 | NV32-SV                  | 30                | 10/10                             | NV32-SV        | 20                | 10/10                             | NF32-SV           | 30                | 7.5/7.5                           | NF32-SV        | 20                | 7.5/7.5                           |
| 2.2                 | NV32-SV                  | 30                | 10/10                             | NV32-SV        | 20                | 10/10                             | NF32-SV           | 30                | 7.5/7.5                           | NF32-SV        | 20                | 7.5/7.5                           |
| 3.7                 | NV63-SV                  | 50                | 15/15                             | NV63-SV        | 40                | 15/15                             | NF63-SV           | 50                | 15/15                             | NF63-SV        | 40                | 15/15                             |

### Three-Phase 400 V Class

| Motor Capacity (kW) | Ground Fault Interrupter |                   |                                   |                |                   |                                   | Circuit Breaker   |                   |                                   |                |                   |                                   |
|---------------------|--------------------------|-------------------|-----------------------------------|----------------|-------------------|-----------------------------------|-------------------|-------------------|-----------------------------------|----------------|-------------------|-----------------------------------|
|                     | Without Reactor*1        |                   |                                   | With Reactor*2 |                   |                                   | Without Reactor*1 |                   |                                   | With Reactor*2 |                   |                                   |
|                     | Model                    | Rated Current (A) | Interrupt Capacity (kA) Icu/Ics*3 | Model          | Rated Current (A) | Interrupt Capacity (kA) Icu/Ics*3 | Model             | Rated Current (A) | Interrupt Capacity (kA) Icu/Ics*3 | Model          | Rated Current (A) | Interrupt Capacity (kA) Icu/Ics*3 |
| 0.2                 | NV32-SV                  | 5                 | 5/5                               | NV32-SV        | 5                 | 5/5                               | NF32-SV           | 3                 | 2.5/2.5                           | NF32-SV        | 3                 | 2.5/2.5                           |
| 0.4                 | NV32-SV                  | 5                 | 5/5                               | NV32-SV        | 5                 | 5/5                               | NF32-SV           | 3                 | 2.5/2.5                           | NF32-SV        | 3                 | 2.5/2.5                           |
| 0.75                | NV32-SV                  | 5                 | 5/5                               | NV32-SV        | 5                 | 5/5                               | NF32-SV           | 5                 | 2.5/2.5                           | NF32-SV        | 5                 | 2.5/2.5                           |
| 1.5                 | NV32-SV                  | 10                | 5/5                               | NV32-SV        | 10                | 5/5                               | NF32-SV           | 10                | 2.5/2.5                           | NF32-SV        | 10                | 2.5/2.5                           |
| 2.2                 | NV32-SV                  | 15                | 5/5                               | NV32-SV        | 10                | 5/5                               | NF32-SV           | 15                | 2.5/2.5                           | NF32-SV        | 10                | 2.5/2.5                           |
| 3.7                 | NV32-SV                  | 20                | 5/5                               | NV32-SV        | 15                | 5/5                               | NF32-SV           | 20                | 2.5/2.5                           | NF32-SV        | 15                | 2.5/2.5                           |
| 5.5                 | NV32-SV                  | 30                | 5/5                               | NV32-SV        | 20                | 5/5                               | NF32-SV           | 30                | 2.5/2.5                           | NF32-SV        | 20                | 2.5/2.5                           |
| 7.5                 | NV32-SV                  | 30                | 5/5                               | NV32-SV        | 30                | 5/5                               | NF32-SV           | 30                | 2.5/2.5                           | NF32-SV        | 30                | 2.5/2.5                           |
| 11                  | NV63-SV                  | 50                | 7.5/7.5                           | NV63-SV        | 40                | 7.5/7.5                           | NF63-SV           | 50                | 7.5/7.5                           | NF63-SV        | 40                | 7.5/7.5                           |
| 15                  | NV125-SV                 | 60                | 25/25                             | NV63-SV        | 50                | 7.5/7.5                           | NF125-SV          | 60                | 25/25                             | NF63-SV        | 50                | 7.5/7.5                           |
| 18.5                | NV125-SV                 | 75                | 25/25                             | NV125-SV       | 60                | 25/25                             | NF125-SV          | 75                | 25/25                             | NF125-SV       | 60                | 25/25                             |

\*1 : The AC or DC reactor is not connected to the drive.

\*2 : The AC or DC reactor is connected to the drive.

\*3 : Icu: Rated ultimate short-circuit breaking capacity Ics: Rated service short-circuit breaking capacity

## Magnetic Contactor

Base device selection on motor capacity.

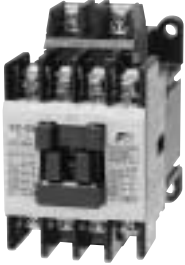

Magnetic Contactor  
[Fuji Electric]

| Motor Capacity (kW) | Three-Phase 200 V Class |                   |                |                   | Single-Phase 200 V Class |                   |                |                   | Three-Phase 400 V Class |                   |                |                   |
|---------------------|-------------------------|-------------------|----------------|-------------------|--------------------------|-------------------|----------------|-------------------|-------------------------|-------------------|----------------|-------------------|
|                     | Without Reactor*1       |                   | With Reactor*2 |                   | Without Reactor*1        |                   | With Reactor*2 |                   | Without Reactor*1       |                   | With Reactor*2 |                   |
|                     | Model                   | Rated Current (A) | Model          | Rated Current (A) | Model                    | Rated Current (A) | Model          | Rated Current (A) | Model                   | Rated Current (A) | Model          | Rated Current (A) |
| 0.1                 | SC-03                   | 11                | SC-03          | 11                | SC-03                    | 11                | SC-03          | 11                | —                       | —                 | —              | —                 |
| 0.2                 | SC-03                   | 11                | SC-03          | 11                | SC-03                    | 11                | SC-03          | 11                | SC-03                   | 7                 | SC-03          | 7                 |
| 0.4                 | SC-03                   | 11                | SC-03          | 11                | SC-03                    | 11                | SC-03          | 11                | SC-03                   | 7                 | SC-03          | 7                 |
| 0.75                | SC-05                   | 13                | SC-03          | 11                | SC-4-0                   | 18                | SC-4-0         | 18                | SC-03                   | 7                 | SC-03          | 7                 |
| 1.5                 | SC-4-0                  | 18                | SC-05          | 13                | SC-N2                    | 35                | SC-N1          | 26                | SC-05                   | 9                 | SC-05          | 9                 |
| 2.2                 | SC-N1                   | 26                | SC-4-0         | 18                | SC-N2                    | 35                | SC-N2          | 35                | SC-4-0                  | 13                | SC-4-0         | 13                |
| 3.7                 | SC-N2                   | 35                | SC-N1          | 26                | SC-N2S                   | 50                | SC-N2S         | 50                | SC-4-1                  | 17                | SC-4-1         | 17                |
| 5.5                 | SC-N2S                  | 50                | SC-N2          | 35                | —                        | —                 | —              | —                 | SC-N2                   | 32                | SC-N1          | 25                |
| 7.5                 | SC-N3                   | 65                | SC-N2S         | 50                | —                        | —                 | —              | —                 | SC-N2S                  | 48                | SC-N2          | 32                |
| 11                  | SC-N4                   | 80                | SC-N4          | 80                | —                        | —                 | —              | —                 | SC-N2S                  | 48                | SC-N2S         | 48                |
| 15                  | SC-N5                   | 93                | SC-N4          | 80                | —                        | —                 | —              | —                 | SC-N3                   | 65                | SC-N2S         | 48                |
| 18.5                | SC-N5                   | 93                | SC-N5          | 93                | —                        | —                 | —              | —                 | SC-N3                   | 65                | SC-N3          | 65                |

\*1 : The AC or DC reactor is not connected to the drive.

\*2 : The AC or DC reactor is connected to the drive.

## Surge Protector

Dimensions (mm)

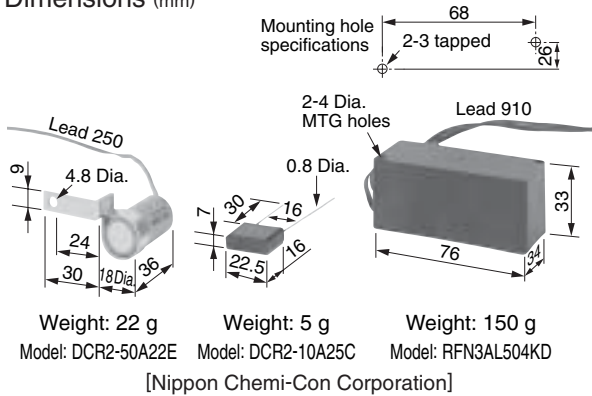

### Product Line

| Surge Protector |  | Model  | Specifications                    | Code No. |
|-----------------|--|--|-----------------------------------|----------|
| 200 V to 230 V  | Large-Capacity Coil (other than relay) | DCR2-50A22E  | 220 Vac 0.5 $\mu$ F+200 $\Omega$  | C002417  |
| 200 V to 240 V  | Control Relay                          | MY2, MY3 [Omron Corporation]<br>MM2, MM4 [Omron Corporation]<br>HH22, HH23 [Fuji Electric] | 250 Vac 0.1 $\mu$ F+100 $\Omega$  | C002482  |
| 380 to 480 V    |  | RFN3AL504KD  | 1000 Vdc 0.5 $\mu$ F+220 $\Omega$ | C002630  |



# Peripheral Devices and Options (continued)

## DC Reactor (UZDA-B for DC circuit)

Base device selection on motor capacity.

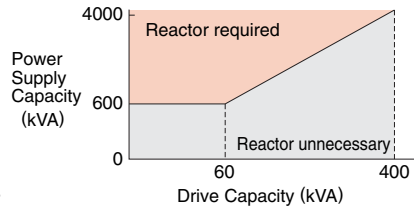
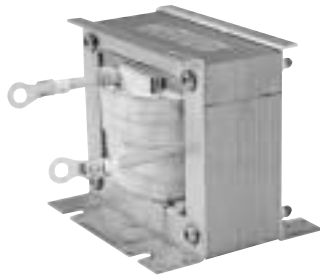

Note: Reactor recommended for power supplies larger than 600 kVA. Use an AC reactor if power supply is 0.2 kW or smaller.

### Connection Diagram

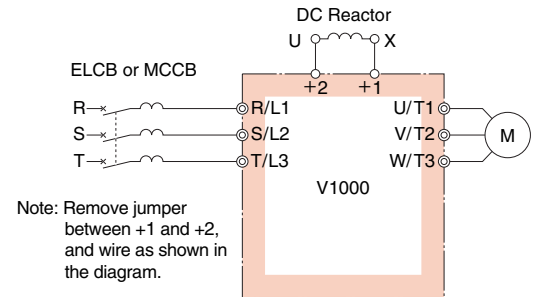

### Dimensions (mm)

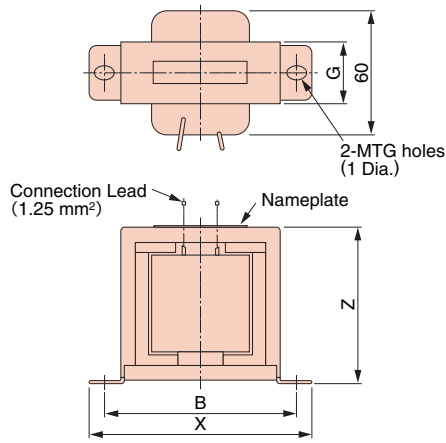

Figure 1

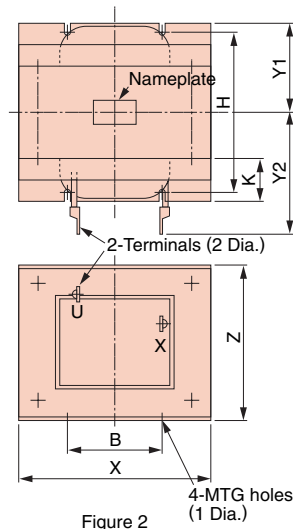

Figure 2

**Three-Phase 200 V Class** Note: Contact Yaskawa directly for information on 200 V class single-phase drives. Use an AC reactor for motor capacities up to 0.2 kW.

| Motor Capacity (kW) | Current (A) | Inductance (mH) | Code No. | Figure | Dimensions (mm) |     |         |     |     |         |     |     |        |        | Weight (kg) | Watt Loss (W) | Wire Gauge* (mm²) |     |    |    |
|---------------------|-------------|-----------------|----------|--------|-----------------|-----|---------|-----|-----|---------|-----|-----|--------|--------|-------------|---------------|-------------------|-----|----|----|
|                     |             |                 |          |        | X               | Y2  | Y1      | Z   | B   | H       | K   | G   | 1 Dia. | 2 Dia. |             |               |                   |     |    |    |
| 0.4<br>0.75         | 5.4         | 8               | X010048  | 1      | 85              | -   | -       | 53  | 74  | -       | -   | 32  | M4     | -      | 0.8         | 8             | 2                 |     |    |    |
| 1.5<br>2.2<br>3.7   |             |                 |          |        | 18              | 3   | X010049 | 2   | 86  | 80      | 36  | 76  | 60     | 55     | 18          | -             | M4                | M5  | 2  | 18 |
| 5.5<br>7.5          | 36          | 1               | X010050  | 105    |                 |     |         |     | 90  | 46      | 93  | 64  | 80     | 26     | -           | M6            | M6                | 3.2 | 22 | 8  |
| 11<br>15            |             |                 |          | 72     |                 |     |         |     | 0.5 | X010051 | 105 | 105 | 56     | 93     | 64          | 100           | 26                | -   | M6 | M8 |
| 18.5                | 90          | 0.4             | X010176  |        | 133             | 120 | 52.5    | 117 |     |         | 86  | 80  | 25     | -      | M6          | M8            | 6.5               | 45  | 30 |    |

### Three-Phase 400 V Class

| Motor Capacity (kW) | Current (A) | Inductance (mH) | Code No. | Figure | Dimensions (mm) |         |         |     |    |     |         |      |        |        | Weight (kg) | Watt Loss (W) | Wire Gauge* (mm²) |    |    |    |    |
|---------------------|-------------|-----------------|----------|--------|-----------------|---------|---------|-----|----|-----|---------|------|--------|--------|-------------|---------------|-------------------|----|----|----|----|
|                     |             |                 |          |        | X               | Y2      | Y1      | Z   | B  | H   | K       | G    | 1 Dia. | 2 Dia. |             |               |                   |    |    |    |    |
| 0.4<br>0.75         | 3.2         | 28              | X010052  | 1      | 85              | -       | -       | 53  | 74 | -   | -       | 32   | M4     | -      | 0.8         | 9             | 2                 |    |    |    |    |
| 1.5<br>2.2          |             |                 |          |        | 5.7             | 11      | X010053 | 1   | 90 | -   | -       | 60   | 80     | -      | -           | 32            | M4                | -  | 1  | 11 | 2  |
| 3.7                 | 12          | 6.3             | X010054  | 2      |                 |         |         |     | 86 | 80  | 36      | 76   | 60     | 55     | 18          | -             | M4                | M5 | 2  | 16 | 2  |
| 5.5<br>7.5          |             |                 |          |        |                 |         |         |     | 23 | 3.6 | X010055 | 105  | 90     | 46     | 93          | 64            | 80                | 26 | -  | M6 | M5 |
| 11                  | 33          | 1.9             | X010056  | 105    | 95              | 51      | 93      | 64  |    |     |         | 90   | 26     | -      | M6          | M6            | 4                 | 26 | 8  |    |    |
| 18.5                |             |                 |          | 47     | 1.3             | X010177 | 115     | 125 |    |     |         | 57.5 | 100    | 72     | 90          | 25            | -                 | M6 | M6 | 6  | 42 |

\*: Cable: IV, 75°C, ambient temperature 45°C, 3 lines max.



## Terminal Type



## Dimensions (mm)

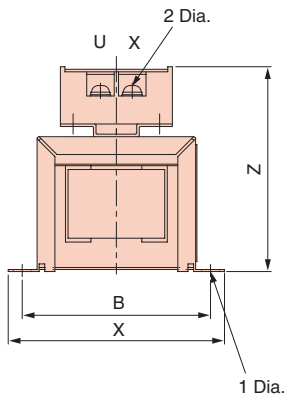

Figure 1

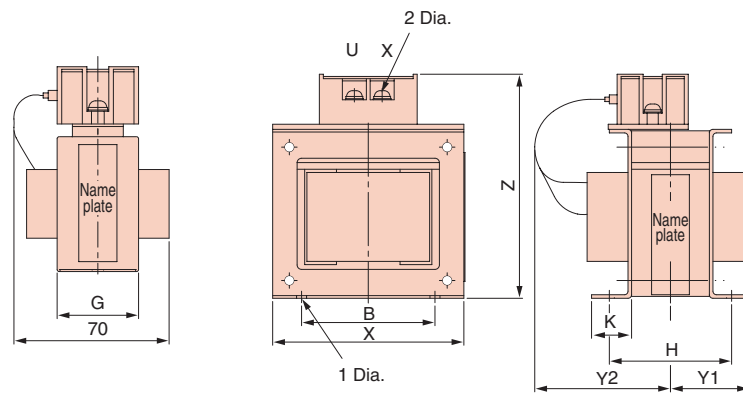

Figure 2

## 200 V Class

| Motor Capacity (kW) | Current (A) | Inductance (mH) | Code No.    | Figure | Dimensions (mm) |       |      |     |    |     |    |    | Weight (kg) | Watt Loss (W) |        |        |
|---------------------|-------------|-----------------|-------------|--------|-----------------|-------|------|-----|----|-----|----|----|-------------|---------------|--------|--------|
|                     |             |                 |             |        | X               | Y2    | Y1   | Z   | B  | H   | K  | G  |             |               | 1 Dia. | 2 Dia. |
| 0.4                 | 5.4         | 8               | 300-027-130 | 1      | 85              | –     | –    | 81  | 74 | –   | –  | 32 | M4          | M4            | 0.8    | 8      |
| 0.75                |             |                 |             |        |                 |       |      |     |    |     |    |    |             |               |        |        |
| 1.5                 |             |                 |             |        |                 |       |      |     |    |     |    |    |             |               |        |        |
| 2.2                 | 18          | 3               | 300-027-131 | 2      | 86              | 84    | 36   | 101 | 60 | 55  | 18 | –  | M4          | M4            | 2      | 18     |
| 3.7                 |             |                 |             |        |                 |       |      |     |    |     |    |    |             |               |        |        |
| 5.5                 | 36          | 1               | 300-027-132 | 2      | 105             | 94    | 46   | 129 | 64 | 80  | 26 | –  | M6          | M4            | 3.2    | 22     |
| 7.5                 |             |                 |             |        |                 |       |      |     |    |     |    |    |             |               |        |        |
| 11                  | 72          | 0.5             | 300-027-133 | 2      | 105             | 124   | 56   | 135 | 64 | 100 | 26 | –  | M6          | M6            | 4.9    | 29     |
| 15                  |             |                 |             |        |                 |       |      |     |    |     |    |    |             |               |        |        |
| 18.5                | 90          | 0.4             | 300-027-139 | 2      | 133             | 147.5 | 52.5 | 160 | 86 | 80  | 25 | –  | M6          | M6            | 6.5    | 44     |

## 400 V Class

| Motor Capacity (kW) | Current (A) | Inductance (mH) | Code No.    | Figure | Dimensions (mm) |       |      |     |    |    |    |    | Weight (kg) | Watt Loss (W) |        |        |
|---------------------|-------------|-----------------|-------------|--------|-----------------|-------|------|-----|----|----|----|----|-------------|---------------|--------|--------|
|                     |             |                 |             |        | X               | Y2    | Y1   | Z   | B  | H  | K  | G  |             |               | 1 Dia. | 2 Dia. |
| 0.4                 | 3.2         | 28              | 300-027-134 | 1      | 85              | –     | –    | 81  | 74 | –  | –  | 32 | M4          | M4            | 0.8    | 9      |
| 0.75                |             |                 |             |        |                 |       |      |     |    |    |    |    |             |               |        |        |
| 1.5                 | 5.7         | 11              | 300-027-135 | 1      | 90              | –     | –    | 88  | 80 | –  | –  | 32 | M4          | M4            | 1      | 11     |
| 2.2                 |             |                 |             |        |                 |       |      |     |    |    |    |    |             |               |        |        |
| 3.7                 | 12          | 6.3             | 300-027-136 | 2      | 86              | 84    | 36   | 101 | 60 | 55 | 18 | –  | M4          | M4            | 2      | 16     |
| 5.5                 |             |                 |             |        |                 |       |      |     |    |    |    |    |             |               |        |        |
| 7.5                 | 23          | 3.6             | 300-027-137 | 2      | 105             | 104   | 46   | 118 | 64 | 80 | 26 | –  | M6          | M4            | 3.2    | 27     |
| 11                  |             |                 |             |        |                 |       |      |     |    |    |    |    |             |               |        |        |
| 15                  | 33          | 1.9             | 300-027-138 | 2      | 105             | 109   | 51   | 129 | 64 | 90 | 26 | –  | M6          | M4            | 4      | 26     |
| 18.5                |             |                 |             |        |                 |       |      |     |    |    |    |    |             |               |        |        |
| 18.5                | 47          | 1.3             | 300-027-140 | 2      | 115             | 142.5 | 57.5 | 136 | 72 | 90 | 25 | –  | M6          | M5            | 6      | 42     |



## AC Reactor (UZBA-B for Input 50/60 Hz)

Base device selection on motor capacity.

### Connection Diagram

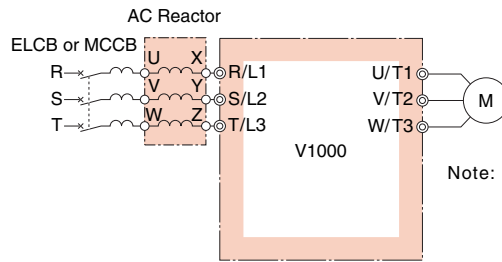

Note: When using low noise type drives (high-carrier frequency of 2.5 kHz or more), do not connect an AC reactor to the output side (U, V, W) of the drive.

### Dimensions (mm)

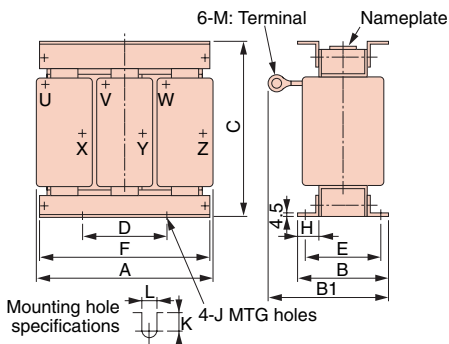

Figure 1

### Three-Phase 200 V Class Note: For the 200 V class single-phase input series, contact us for inquiry.

| Motor Capacity (kW) | Current (A) | Inductance (mH) | Code No. | Figure | Dimensions (mm) |     |       |     |    |    |     |    |    |      |   | Weight (kg) | Watt Loss (W) |      |
|---------------------|-------------|-----------------|----------|--------|-----------------|-----|-------|-----|----|----|-----|----|----|------|---|-------------|---------------|------|
|                     |             |                 |          |        | A               | B   | B1    | C   | D  | E  | F   | H  | J  | K    | L |             |               | M    |
| 3.7                 | 20          | 0.53            | X002491  | 1      | 130             | 88  | 114   | 105 | 50 | 70 | 130 | 22 | M6 | 11.5 | 7 | M5          | 3             | 35   |
| 5.5                 | 30          | 0.35            | X002492  |        |                 |     | 119   |     |    |    |     |    |    | 9    |   |             |               | 45   |
| 7.5                 | 40          | 0.265           | X002493  |        |                 | 98  | 139   |     |    |    |     |    |    | 80   |   |             |               | 11.5 |
| 11                  | 60          | 0.18            | X002495  |        | 160             | 105 | 147.5 | 130 | 75 | 85 | 160 | 25 | M6 | 10   | 7 | M6          | 6             | 65   |
| 15                  | 80          | 0.13            | X002497  |        | 180             | 100 | 155   | 150 | 75 | 80 | 180 | 25 | M6 | 10   | 7 | M8          | 8             | 75   |
| 18.5                | 90          | 0.12            | X002498  |        |                 |     | 150   |     |    |    |     |    |    |      |   |             |               | 90   |

### Three-Phase 400 V Class

| Motor Capacity (kW) | Current (A) | Inductance (mH) | Code No. | Figure | Dimensions (mm) |     |       |     |    |    |     |    |    |    |   | Weight (kg) | Watt Loss (W) |    |
|---------------------|-------------|-----------------|----------|--------|-----------------|-----|-------|-----|----|----|-----|----|----|----|---|-------------|---------------|----|
|                     |             |                 |          |        | A               | B   | B1    | C   | D  | E  | F   | H  | J  | K  | L |             |               | M  |
| 7.5                 | 20          | 1.06            | X002502  | 1      | 160             | 90  | 115   | 130 | 75 | 70 | 160 | 25 | M6 | 10 | 7 | M5          | 5             | 50 |
| 11                  | 30          | 0.7             | X002503  |        |                 | 105 | 132.5 |     |    | 85 |     |    |    |    |   |             | 6             | 65 |
| 15                  | 40          | 0.53            | X002504  |        | 180             | 100 | 140   | 150 | 75 | 80 | 180 | 25 | M6 | 10 | 7 | M6          | 8             | 90 |
| 18.5                | 50          | 0.42            | X002505  |        |                 |     | 145   |     |    |    |     |    |    |    |   |             |               | 90 |

### Terminal Type

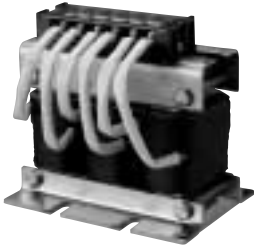

### Dimensions (mm)

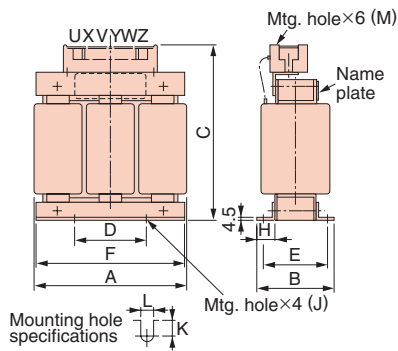

Figure 1

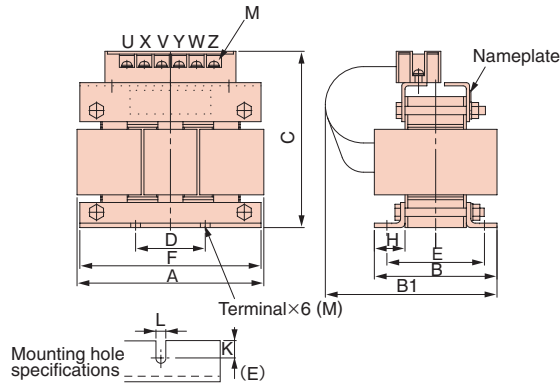

Figure 2

### 200 V Class

| Motor Capacity (kW) | Current (A) | Inductance (mH) | Code No.    | Figure | Dimensions (mm) |     |     |     |    |    |     |    |    |      |    | Weight (kg) | Watt Loss (W) |     |
|---------------------|-------------|-----------------|-------------|--------|-----------------|-----|-----|-----|----|----|-----|----|----|------|----|-------------|---------------|-----|
|                     |             |                 |             |        | A               | B   | B1  | C   | D  | E  | F   | H  | J  | K    | L  |             |               | M   |
| 0.1                 | 2           | 7               | X002764     | 1      | 120             | 71  | -   | 120 | 40 | 50 | 105 | 20 | M6 | 10.5 | 7  | M4          | 2.5           | 15  |
| 0.2                 | 2           | 7               |             |        |                 |     |     |     |    |    |     |    |    |      |    |             |               |     |
| 0.4                 | 2.5         | 4.2             | X002553     |        | 130             | 88  | -   | 130 | 50 | 70 | 130 | 22 | M6 | 11.5 | 7  | M4          | 3             | 25  |
| 0.75                | 5           | 2.1             | X002554     |        |                 |     |     |     |    |    |     |    |    |      |    |             |               |     |
| 1.5                 | 10          | 1.1             | X002489     |        |                 |     |     |     |    |    |     |    |    |      |    |             |               |     |
| 2.2                 | 15          | 0.71            | X002490     |        |                 |     |     |     |    |    |     |    |    |      |    |             |               |     |
| 3.7                 | 20          | 0.53            | 300-027-120 | 2      | 135             | 88  | 140 | 130 | 50 | 70 | 130 | 22 | M6 | -    | 7  | M4          | 3             | 35  |
| 5.5                 | 30          | 0.35            | 300-027-121 |        |                 |     | 150 |     |    |    |     |    |    |      |    |             |               |     |
| 7.5                 | 40          | 0.265           | 300-027-122 |        | 135             | 98  | 160 | 140 | 50 | 80 | 130 | 22 | M6 | 11.5 | 7  | M5          | 4             | 50  |
| 11                  | 60          | 0.18            | 300-027-123 |        |                 |     |     |     |    |    |     |    |    |      |    |             |               |     |
| 15                  | 80          | 0.13            | 300-027-124 |        | 185             | 100 | 180 | 195 | 75 | 80 | 180 | 25 | M6 | 10   | M6 | 8           | 75            |     |
| 18.5                | 90          | 0.12            | 300-027-125 |        |                 |     |     |     |    |    |     |    |    |      |    |             |               | 185 |

### 400 V Class

| Motor Capacity (kW) | Current (A) | Inductance (mH) | Code No.    | Figure | Dimensions (mm) |     |     |     |    |    |     |    |    |      |   | Weight (kg) | Watt Loss (W) |    |
|---------------------|-------------|-----------------|-------------|--------|-----------------|-----|-----|-----|----|----|-----|----|----|------|---|-------------|---------------|----|
|                     |             |                 |             |        | A               | B   | B1  | C   | D  | E  | F   | H  | J  | K    | L |             |               | M  |
| 0.2                 | 1.3         | 18              | X002561     | 1      | 120             | 71  | -   | 120 | 40 | 50 | 105 | 20 | M6 | 10.5 | 7 | M4          | 2.5           | 15 |
| 0.4                 | 1.3         | 18              |             |        |                 |     |     |     |    |    |     |    |    |      |   |             |               |    |
| 0.75                | 2.5         | 8.4             | X002562     |        | 130             | 88  | -   | 130 | 50 | 70 | 130 | 22 | M6 | 9    | 7 | M4          | 3             | 25 |
| 1.5                 | 5           | 4.2             | X002563     |        |                 |     |     |     |    |    |     |    |    |      |   |             |               |    |
| 2.2                 | 7.5         | 3.6             | X002564     |        |                 |     |     |     |    |    |     |    |    |      |   |             |               |    |
| 3.7                 | 10          | 2.2             | X002500     |        |                 |     |     |     |    |    |     |    |    |      |   |             |               |    |
| 5.5                 | 15          | 1.42            | X002501     | 2      | 165             | 90  | 160 | 155 | 75 | 70 | 160 | 25 | M6 | 10   | 7 | M4          | 5             | 50 |
| 7.5                 | 20          | 1.06            | 300-027-126 |        |                 |     |     |     |    |    |     |    |    |      |   |             |               |    |
| 11                  | 30          | 0.7             | 300-027-127 |        | 185             | 100 | 170 | 185 | 75 | 80 | 180 | 25 | M6 | 10   | 7 | M5          | 8             | 90 |
| 15                  | 40          | 0.53            | 300-027-128 |        |                 |     |     |     |    |    |     |    |    |      |   |             |               |    |
| 18.5                | 50          | 0.42            | 300-027-129 |        |                 |     |     |     |    |    |     |    |    |      |   |             |               |    |



# Peripheral Devices and Options (continued)

## Zero Phase Reactor

Zero-phase reactor should match wire gauge.\*

\*: Current values for wire gauges may vary based on electrical codes.

The table below lists selections based on Japanese electrical standards and Yaskawa's ND rating. Contact Yaskawa for questions regarding UL.

Finemet Zero-Phase Reactor to Reduce Radio Noise Note: Finemet is a registered trademark of Hitachi Metals, Ltd.



[Hitachi Metals, Ltd.]

### Connection Diagram

Compatible with the input and output side of the drive.

Example: Connection to output terminal

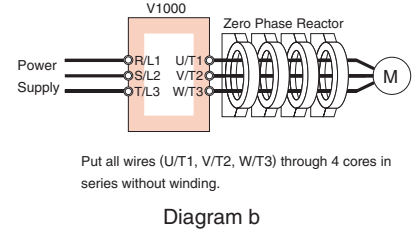
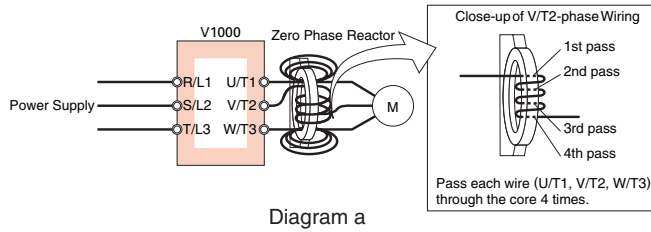

### Dimensions (mm)

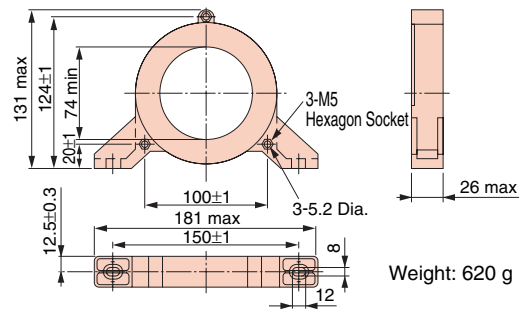
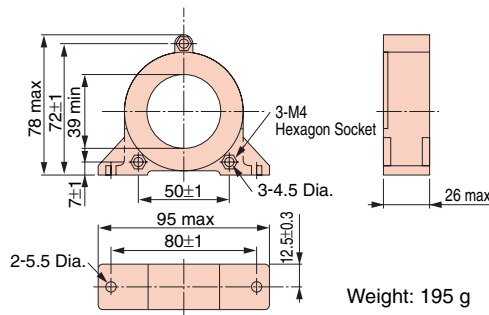

### Three-Phase 200 V Class

| V1000               |                                      | Zero Phase Reactor |           |      |         |
|---------------------|--------------------------------------|--------------------|-----------|------|---------|
| Motor Capacity (kW) | Recommended Gauge (mm <sup>2</sup> ) | Model              | Code No.  | Qty. | Diagram |
| 0.1                 | 2                                    | F6045GB            | FIL001098 | 1    | a       |
| 0.2                 | 2                                    | F6045GB            | FIL001098 | 1    | a       |
| 0.4                 | 2                                    | F6045GB            | FIL001098 | 1    | a       |
| 0.75                | 2                                    | F6045GB            | FIL001098 | 1    | a       |
| 1.5                 | 2                                    | F6045GB            | FIL001098 | 1    | a       |
| 2.2                 | 2                                    | F6045GB            | FIL001098 | 1    | a       |
| 3.7                 | 3.5                                  | F6045GB            | FIL001098 | 1    | a       |
| 5.5                 | 5.5                                  | F6045GB            | FIL001098 | 1    | a       |
| 7.5                 | 8                                    | F11080GB           | FIL001097 | 1    | a       |
| 11                  | 14                                   | F6045GB            | FIL001098 | 4    | b       |
| 15                  | 22                                   | F6045GB            | FIL001098 | 4    | b       |
| 18.5                | 30                                   | F6045GB            | FIL001098 | 4    | b       |

### Three-Phase 400 V Class

| V1000               |                                      | Zero Phase Reactor |           |      |         |
|---------------------|--------------------------------------|--------------------|-----------|------|---------|
| Motor Capacity (kW) | Recommended Gauge (mm <sup>2</sup> ) | Model              | Code No.  | Qty. | Diagram |
| 0.2                 | 2                                    | F6045GB            | FIL001098 | 1    | a       |
| 0.4                 | 2                                    | F6045GB            | FIL001098 | 1    | a       |
| 0.75                | 2                                    | F6045GB            | FIL001098 | 1    | a       |
| 1.5                 | 2                                    | F6045GB            | FIL001098 | 1    | a       |
| 2.2                 | 2                                    | F6045GB            | FIL001098 | 1    | a       |
| 3.0                 | 2                                    | F6045GB            | FIL001098 | 1    | a       |
| 3.7                 | 2                                    | F6045GB            | FIL001098 | 1    | a       |
| 5.5                 | 2                                    | F6045GB            | FIL001098 | 1    | a       |
| 7.5                 | 5.5                                  | F6045GB            | FIL001098 | 1    | a       |
| 11                  | 5.5                                  | F6045GB            | FIL001098 | 1    | a       |
| 15                  | 14                                   | F6045GB            | FIL001098 | 4    | b       |
| 18.5                | 14                                   | F6045GB            | FIL001098 | 4    | b       |

### Single-Phase 200 V Class

| V1000               |                                      | Zero Phase Reactor |           |      |         |
|---------------------|--------------------------------------|--------------------|-----------|------|---------|
| Motor Capacity (kW) | Recommended Gauge (mm <sup>2</sup> ) | Model              | Code No.  | Qty. | Diagram |
| 0.1                 | 2                                    | F6045GB            | FIL001098 | 1    | a       |
| 0.2                 | 2                                    | F6045GB            | FIL001098 | 1    | a       |
| 0.4                 | 2                                    | F6045GB            | FIL001098 | 1    | a       |
| 0.75                | 2                                    | F6045GB            | FIL001098 | 1    | a       |
| 1.5                 | 2                                    | F6045GB            | FIL001098 | 1    | a       |
| 2.2                 | 3.5                                  | F6045GB            | FIL001098 | 1    | a       |
| 3.7                 | 8                                    | F11080GB           | FIL001097 | 1    | a       |

## Fuse/Fuse Holder

Install a fuse to the drive input terminals to prevent damage in case a fault occurs.  
Refer to the instruction manual for information on UL-approved components.

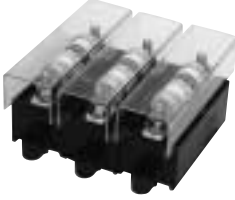

[Fuji Electric]

### Three-Phase 200 V Class

| Model<br>CIMR-VA2A | AC Power Supply / DC Power Supply |   |       |       |             |          |        |      |
|--------------------|-----------------------------------|---|-------|-------|-------------|----------|--------|------|
|                    | Fuse                              |   |       |       | Fuse Holder |          |        |      |
| Model              | Code No.                          | Rated Short-Circuit Breaking Current (kA) | Qty.* | Model | Code No.    | Qty.*    | Figure |      |
| 0001               | CR6L-20/UL                        | FU002087                                  | 100   | 3     | CMS-4       | FU002091 | 3      | 1    |
| 0002               | CR6L-20/UL                        | FU002087                                  |       |       |             |          |        |      |
| 0004               | CR6L-20/UL                        | FU002087                                  |       |       |             |          |        |      |
| 0006               | CR6L-30/UL                        | FU002088                                  |       |       |             |          |        |      |
| 0008               | CR6L-50/UL                        | FU000935                                  |       |       |             |          |        |      |
| 0010               | CR6L-50/UL                        | FU000935                                  |       |       |             |          |        |      |
| 0012               | CR6L-50/UL                        | FU000935                                  |       |       |             |          |        |      |
| 0018               | CR6L-75/UL                        | FU002089                                  |       |       |             |          |        |      |
| 0020               | CR6L-75/UL                        | FU002089                                  |       |       |             |          |        |      |
| 0030               | CR6L-100/UL                       | FU000927                                  |       |       |             |          |        |      |
| 0040               | CR6L-150/UL                       | FU000928                                  | 3     | CMS-5 | FU002092    | 3        | 2      |      |
| 0056               | CR6L-150/UL                       | FU000928                                  |       |       |             |          |        |      |
| 0069               | CR6L-200/UL                       | FU000929                                  |       |       |             |          |        |      |
|                    |                                   |   | 3     |       |             |          |        | Note |

\* : Multiple fuses are needed when using an AC power supply. DC power requires only two fuses.  
Note: Manufacturer does not recommend a specific fuse holder for this fuse.  
Contact the manufacturer for information on fuse dimensions.

### Single-Phase 200 V Class

| Model<br>CIMR-VABA | AC Power Supply / DC Power Supply |   |      |       |             |          |        |   |       |          |   |   |
|--------------------|-----------------------------------|---|------|-------|-------------|----------|--------|---|-------|----------|---|---|
|                    | Fuse                              |   |      |       | Fuse Holder |          |        |   |       |          |   |   |
| Model              | Code No.                          | Rated Short-Circuit Breaking Current (kA) | Qty. | Model | Code No.    | Qty.     | Figure |   |       |          |   |   |
| 0001               | CR6L-20/UL                        | FU002087                                  | 100  | 2     | CMS-4       | FU002091 | 2      | 1 |       |          |   |   |
| 0002               | CR6L-30/UL                        | FU002088                                  |      |       |             |          |        |   |       |          |   |   |
| 0003               | CR6L-50/UL                        | FU000935                                  |      |       |             |          |        |   |       |          |   |   |
| 0006               | CR6L-75/UL                        | FU002089                                  |      |       |             |          |        |   |       |          |   |   |
| 0010               | CR6L-100/UL                       | FU000927                                  |      |       |             |          |        |   |       |          |   |   |
| 0012               | CR6L-100/UL                       | FU000927                                  |      |       |             |          |        |   |       |          |   |   |
| 0018               | CR6L-150/UL                       | FU000928                                  |      |       |             |          |        |   |       |          |   |   |
|                    |                                   |   |      | 2     |             |          |        |   | CMS-5 | FU002092 | 2 | 1 |
|                    |                                   |   |      | 2     |             |          |        |   |       |          |   |   |

## Connection Diagram

DC Input Power Supply (example shows two V1000 drives connected in parallel.)  
For use with an AC power supply see the connection diagram on page 22.

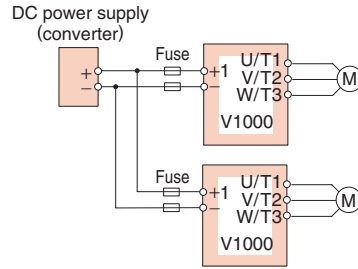

Note: When connecting multiple drives together, make sure that each drive has its own fuse. If any one fuse blows, all fuses should be replaced.

### Three-Phase 400 V Class

| Model<br>CIMR-VA4A | AC Power Supply / DC Power Supply |   |       |       |             |          |        |   |
|--------------------|-----------------------------------|---|-------|-------|-------------|----------|--------|---|
|                    | Fuse                              |   |       |       | Fuse Holder |          |        |   |
| Model              | Code No.                          | Rated Short-Circuit Breaking Current (kA) | Qty.* | Model | Code No.    | Qty.*    | Figure |   |
| 0001               | CR6L-20/UL                        | FU002087                                  | 100   | 3     | CMS-4       | FU002091 | 3      | 1 |
| 0002               | CR6L-20/UL                        | FU002087                                  |       |       |             |          |        |   |
| 0004               | CR6L-50/UL                        | FU000935                                  |       |       |             |          |        |   |
| 0005               | CR6L-50/UL                        | FU000935                                  |       |       |             |          |        |   |
| 0007               | CR6L-50/UL                        | FU000935                                  |       |       |             |          |        |   |
| 0009               | CR6L-50/UL                        | FU000935                                  |       |       |             |          |        |   |
| 0011               | CR6L-50/UL                        | FU000935                                  |       |       |             |          |        |   |
| 0018               | CR6L-50/UL                        | FU000935                                  |       |       |             |          |        |   |
| 0023               | CR6L-75/UL                        | FU002089                                  |       |       |             |          |        |   |
| 0031               | CR6L-100/UL                       | FU000927                                  |       |       |             |          |        |   |
| 0038               | CR6L-150/UL                       | FU000928                                  | 3     | CMS-5 | FU002092    | 3        | 2      |   |
|                    |                                   |   | 3     |       |             |          |        |   |

\* : Multiple fuses are needed when using an AC power supply. DC power requires only two fuses.

## Dimensions (mm)

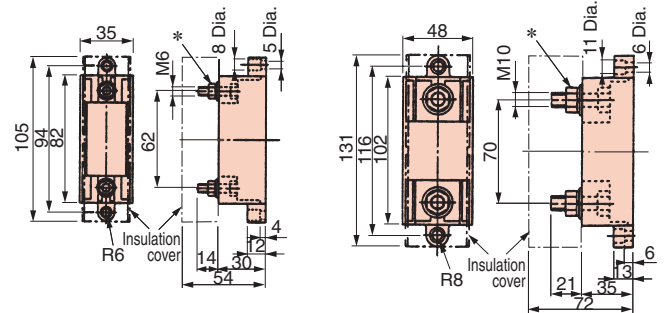

Figure 1

Figure 2

\* : Mounting components supplied separately. Tighten bolt when fuse is installed.

## Capacitor-type Noise Filter

Capacitor-type noise filter exclusively designed for drive input. The noise filter can be used in combination with a zero-phase reactor. For both 200 V and 400 V classes.  
Note: The capacitor-type noise filter can be used for drive input only. Do not connect the noise filter to the output terminals.



[Okaya Electric Industries]

## Connection Diagram

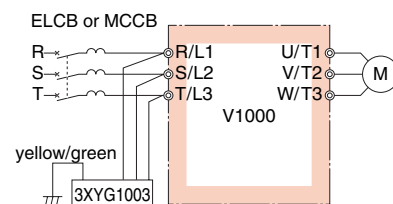

## Specifications

| Rated Voltage | Capacitance (3 devices each)                                     | Operating Temperature Range (°C) |
|---------------|--|----------------------------------|
| 440 V         | X (Δ connection): 0.1 μ F±20%<br>Y (λ connection): 0.003 μ F±20% | -40 to +85                       |

Note: For use with 460 V and 480 V units, contact Yaskawa directly.

## Dimensions (mm)

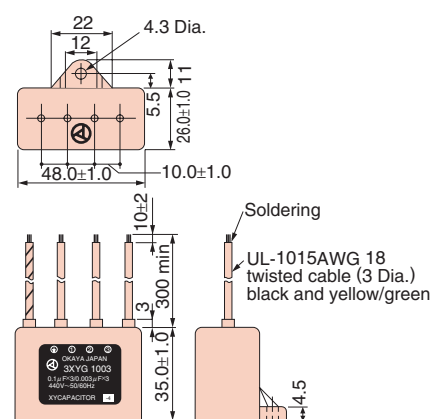

## Input Noise Filter

Base device selection on motor capacity.

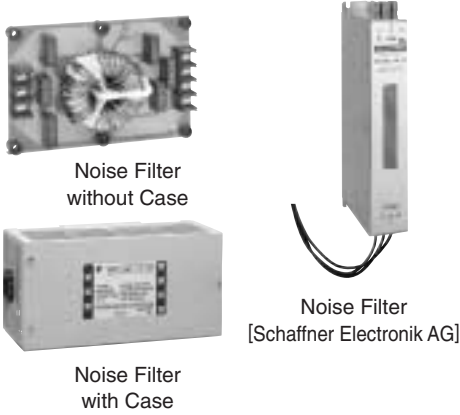

Note: Contact Yaskawa for CE compliant models (EMC directive).

### Connection Diagram

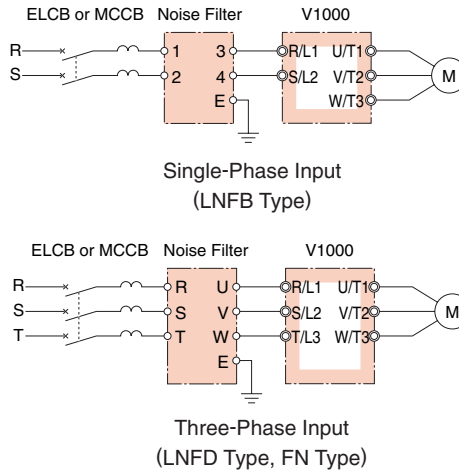

Note: Do not connect the input noise filter to the drive output terminals (U, V, W). Connect in parallel when using two filters. Only a single noise filter is required if the filter is made by Schaffner Elektronik AG.

Connecting Noise Filters in Parallel to the Input or Output Side (examples shows two filters in parallel)

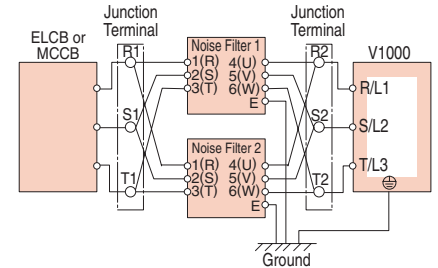

Note: When wiring contactors in parallel, make sure wiring lengths are the same to keep current flow even to the relay terminals. Noise filters and grounding wire should be as heavy and as short as possible.

### Three-Phase 200 V Class

| Motor Capacity (kW) | Noise Filter without Case |           |      |                   | Noise Filter with Case |           |      |                   | Noise Filter by Schaffner Elektronik AG |           |      |                   |
|---------------------|---------------------------|-----------|------|-------------------|------------------------|-----------|------|-------------------|---|-----------|------|-------------------|
|                     | Model                     | Code No.  | Qty. | Rated Current (A) | Model                  | Code No.  | Qty. | Rated Current (A) | Model                                   | Code No.  | Qty. | Rated Current (A) |
| 0.1                 | LNFD-2103DY               | FIL000132 | 1    | 10                | LNFD-2103HY            | FIL000140 | 1    | 10                | —                                       | —         | —    | —                 |
| 0.2                 | LNFD-2103DY               | FIL000132 | 1    | 10                | LNFD-2103HY            | FIL000140 | 1    | 10                | —                                       | —         | —    | —                 |
| 0.4                 | LNFD-2103DY               | FIL000132 | 1    | 10                | LNFD-2103HY            | FIL000140 | 1    | 10                | —                                       | —         | —    | —                 |
| 0.75                | LNFD-2103DY               | FIL000132 | 1    | 10                | LNFD-2103HY            | FIL000140 | 1    | 10                | —                                       | —         | —    | —                 |
| 1.5                 | LNFD-2103DY               | FIL000132 | 1    | 10                | LNFD-2103HY            | FIL000140 | 1    | 10                | —                                       | —         | —    | —                 |
| 2.2                 | LNFD-2153DY               | FIL000133 | 1    | 15                | LNFD-2153HY            | FIL000141 | 1    | 15                | —                                       | —         | —    | —                 |
| 3.7                 | LNFD-2303DY               | FIL000135 | 1    | 30                | LNFD-2303HY            | FIL000143 | 1    | 30                | —                                       | —         | —    | —                 |
| 5.5                 | LNFD-2203DY               | FIL000134 | 2    | 40                | LNFD-2203HY            | FIL000142 | 2    | 40                | FN258L-42-07                            | FIL001065 | 1    | 42                |
| 7.5                 | LNFD-2303DY               | FIL000135 | 2    | 60                | LNFD-2303HY            | FIL000143 | 2    | 60                | FN258L-55-07                            | FIL001066 | 1    | 55                |
| 11                  | LNFD-2303DY               | FIL000135 | 3    | 90                | LNFD-2303HY            | FIL000143 | 3    | 90                | FN258L-75-34                            | FIL001067 | 1    | 75                |
| 15                  | LNFD-2303DY               | FIL000135 | 3    | 90                | LNFD-2303HY            | FIL000143 | 3    | 90                | FN258L-100-35                           | FIL001068 | 1    | 100               |
| 18.5                | LNFD-2303DY               | FIL000135 | 4    | 120               | LNFD-2303HY            | FIL000143 | 4    | 120               | FN258L-100-35                           | FIL001068 | 1    | 100               |

### Single-Phase 200 V Class

| Motor Capacity (kW) | Noise Filter without Case |           |      |                   | Noise Filter with Case |           |      |                   |
|---------------------|---------------------------|-----------|------|-------------------|------------------------|-----------|------|-------------------|
|                     | Model                     | Code No.  | Qty. | Rated Current (A) | Model                  | Code No.  | Qty. | Rated Current (A) |
| 0.1                 | LNFB-2102DY               | FIL000128 | 1    | 10                | LNFB-2102HY            | FIL000136 | 1    | 10                |
| 0.2                 | LNFB-2102DY               | FIL000128 | 1    | 10                | LNFB-2102HY            | FIL000136 | 1    | 10                |
| 0.4                 | LNFB-2152DY               | FIL000129 | 1    | 15                | LNFB-2152HY            | FIL000137 | 1    | 15                |
| 0.75                | LNFB-2202DY               | FIL000130 | 1    | 20                | LNFB-2202HY            | FIL000138 | 1    | 20                |
| 1.5                 | LNFB-2302DY               | FIL000131 | 1    | 30                | LNFB-2302HY            | FIL000139 | 1    | 30                |
| 2.2                 | LNFB-2202DY               | FIL000130 | 2    | 40                | LNFB-2202HY            | FIL000138 | 2    | 40                |
| 3.7                 | LNFB-2302DY               | FIL000131 | 2    | 60                | LNFB-2302HY            | FIL000139 | 2    | 60                |

### Three-Phase 400 V Class

| Motor Capacity (kW) | Noise Filter without Case |           |      |                   | Noise Filter with Case |           |      |                   | Noise Filter by Schaffner Elektronik AG |           |      |                   |
|---------------------|---------------------------|-----------|------|-------------------|------------------------|-----------|------|-------------------|---|-----------|------|-------------------|
|                     | Model                     | Code No.  | Qty. | Rated Current (A) | Model                  | Code No.  | Qty. | Rated Current (A) | Model                                   | Code No.  | Qty. | Rated Current (A) |
| 0.2                 | LNFD-4053DY               | FIL000144 | 1    | 5                 | LNFD-4053HY            | FIL000149 | 1    | 5                 | —                                       | —         | —    | —                 |
| 0.4                 | LNFD-4053DY               | FIL000144 | 1    | 5                 | LNFD-4053HY            | FIL000149 | 1    | 5                 | —                                       | —         | —    | —                 |
| 0.75                | LNFD-4053DY               | FIL000144 | 1    | 5                 | LNFD-4053HY            | FIL000149 | 1    | 5                 | —                                       | —         | —    | —                 |
| 1.5                 | LNFD-4103DY               | FIL000145 | 1    | 10                | LNFD-4103HY            | FIL000150 | 1    | 10                | —                                       | —         | —    | —                 |
| 2.2                 | LNFD-4103DY               | FIL000145 | 1    | 10                | LNFD-4103HY            | FIL000150 | 1    | 10                | —                                       | —         | —    | —                 |
| 3.7                 | LNFD-4153DY               | FIL000146 | 1    | 15                | LNFD-4153HY            | FIL000151 | 1    | 15                | —                                       | —         | —    | —                 |
| 5.5                 | LNFD-4203DY               | FIL000147 | 1    | 20                | LNFD-4203HY            | FIL000152 | 1    | 20                | —                                       | —         | —    | —                 |
| 7.5                 | LNFD-4303DY               | FIL000148 | 1    | 30                | LNFD-4303HY            | FIL000153 | 1    | 30                | —                                       | —         | —    | —                 |
| 11                  | LNFD-4203DY               | FIL000147 | 2    | 40                | LNFD-4203HY            | FIL000152 | 2    | 40                | FN258L-42-07                            | FIL001065 | 1    | 42                |
| 15                  | LNFD-4303DY               | FIL000148 | 2    | 60                | LNFD-4303HY            | FIL000153 | 2    | 60                | FN258L-55-07                            | FIL001066 | 1    | 55                |
| 18.5                | LNFD-4303DY               | FIL000148 | 2    | 60                | LNFD-4303HY            | FIL000153 | 2    | 60                | FN258L-55-07                            | FIL001066 | 1    | 55                |

Dimensions (mm)  
Without Case

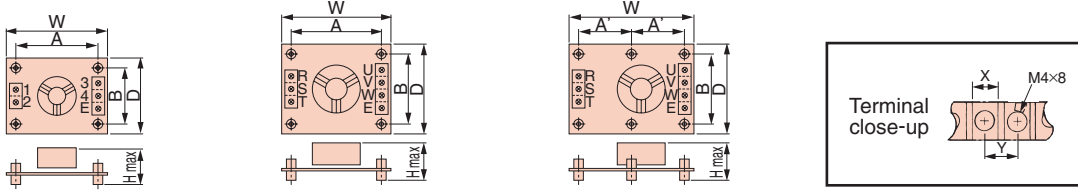
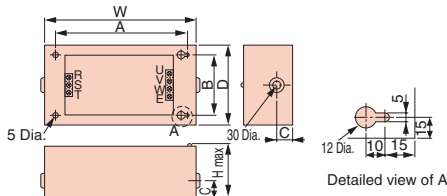

Figure 1 (Single-Phase) Figure 2 (Three-Phase) Figure 3 (Three-Phase)

| Model       | Code No.  | Figure | Dimensions (mm) |     |     |     |    |     | Terminal |    | Mounting Screw | Weight (kg) |
|-------------|-----------|--------|-----------------|-----|-----|-----|----|-----|----------|----|----------------|-------------|
|             |           |        | W               | D   | H   | A   | A' | B   | X        | Y  |                |             |
| LNFD-2103DY | FIL000132 | 2      | 120             | 80  | 55  | 108 | -  | 68  |          |    | M4x4,20mm      | 0.2         |
| LNFD-2153DY | FIL000133 | 2      | 120             | 80  | 55  | 108 | -  | 68  | 9        | 11 | M4x4,20mm      | 0.2         |
| LNFD-2203DY | FIL000134 | 2      | 170             | 90  | 70  | 158 | -  | 78  |          |    | M4x4,20mm      | 0.4         |
| LNFD-2303DY | FIL000135 | 3      | 170             | 110 | 70  | -   | 79 | 98  | 10       | 13 | M4x6,20mm      | 0.5         |
| LNFB-2102DY | FIL000128 | 1      | 120             | 80  | 50  | 108 | -  | 68  |          |    | M4x4,20mm      | 0.1         |
| LNFB-2152DY | FIL000129 | 1      | 120             | 80  | 50  | 108 | -  | 68  | 9        | 11 | M4x4,20mm      | 0.2         |
| LNFB-2202DY | FIL000130 | 1      | 120             | 80  | 50  | 108 | -  | 68  |          |    | M4x4,20mm      | 0.2         |
| LNFB-2302DY | FIL000131 | 1      | 130             | 90  | 65  | 118 | -  | 78  | 10       | 13 | M4x4,20mm      | 0.3         |
| LNFD-4053DY | FIL000144 | 3      | 170             | 130 | 75  | -   | 79 | 118 |          |    | M4x6,30mm      | 0.3         |
| LNFD-4103DY | FIL000145 | 3      | 170             | 130 | 95  | -   | 79 | 118 | 9        | 11 | M4x6,30mm      | 0.4         |
| LNFD-4153DY | FIL000146 | 3      | 170             | 130 | 95  | -   | 79 | 118 |          |    | M4x6,30mm      | 0.4         |
| LNFD-4203DY | FIL000147 | 3      | 200             | 145 | 100 | -   | 94 | 133 |          |    | M4x4,30mm      | 0.5         |
| LNFD-4303DY | FIL000148 | 3      | 200             | 145 | 100 | -   | 94 | 133 | 10       | 13 | M4x4,30mm      | 0.6         |

With Case



Note: The figure shows an example of three-phase input.

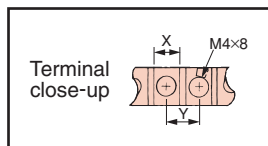

| Model       | Code No.  | Dimensions (mm) |     |     |     |     |    | Terminal |    | Mounting Screw | Weight (kg) |
|-------------|-----------|-----------------|-----|-----|-----|-----|----|----------|----|----------------|-------------|
|             |           | W               | D   | H   | A   | B   | C  | X        | Y  |                |             |
| LNFD-2103HY | FIL000140 | 185             | 95  | 85  | 155 | 65  | 33 | 9        | 11 | M4x4,10mm      | 0.9         |
| LNFD-2153HY | FIL000141 | 185             | 95  | 85  | 155 | 65  | 33 |          |    | M4x4,10mm      | 0.9         |
| LNFD-2203HY | FIL000142 | 240             | 125 | 100 | 210 | 95  | 33 |          |    | M4x4,10mm      | 1.5         |
| LNFD-2303HY | FIL000143 | 240             | 125 | 100 | 210 | 95  | 33 | 10       | 13 | M4x4,10mm      | 1.6         |
| LNFB-2102HY | FIL000136 | 185             | 95  | 85  | 155 | 65  | 33 |          |    | M4x4,10mm      | 0.8         |
| LNFB-2152HY | FIL000137 | 185             | 95  | 85  | 155 | 65  | 33 | 9        | 11 | M4x4,10mm      | 0.8         |
| LNFB-2202HY | FIL000138 | 185             | 95  | 85  | 155 | 65  | 33 |          |    | M4x4,10mm      | 0.9         |
| LNFB-2302HY | FIL000139 | 200             | 105 | 95  | 170 | 75  | 33 | 10       | 13 | M4x4,10mm      | 1.1         |
| LNFD-4053HY | FIL000149 | 235             | 140 | 120 | 205 | 110 | 43 |          |    | M4x4,10mm      | 1.6         |
| LNFD-4103HY | FIL000150 | 235             | 140 | 120 | 205 | 110 | 43 | 9        | 11 | M4x4,10mm      | 1.7         |
| LNFD-4153HY | FIL000151 | 235             | 140 | 120 | 205 | 110 | 43 |          |    | M4x4,10mm      | 1.7         |
| LNFD-4203HY | FIL000152 | 270             | 155 | 125 | 240 | 125 | 43 |          |    | M4x4,10mm      | 2.2         |
| LNFD-4303HY | FIL000153 | 270             | 155 | 125 | 240 | 125 | 43 | 10       | 13 | M4x4,10mm      | 2.2         |

Manufactured by Schaffner Elektronik AG

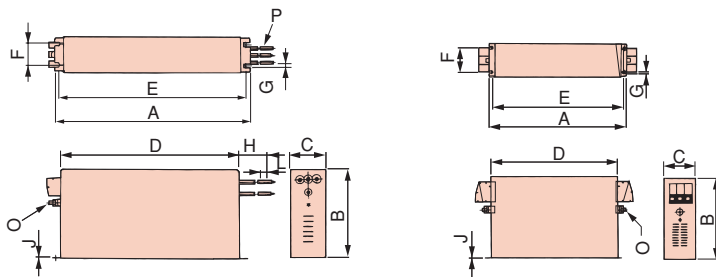

Figure 1

Figure 2

| Model         | Figure | Dimensions (mm) |       |        |         |     |    |     |     |     |    |     | Wire Gauge | Weight (kg) |
|---------------|--------|-----------------|-------|--------|---------|-----|----|-----|-----|-----|----|-----|------------|-------------|
|               |        | A               | B     | C      | D       | E   | F  | G   | H   | J   | L  | O   |            |             |
| FN258L-42-07  | 1      | 329             | 185±1 | 70     | 300     | 314 | 45 | 6.5 | 500 | 1.5 | 12 | M6  | AWG8       | 2.8         |
| FN258L-55-07  | 1      | 329             | 185±1 | 80     | 300     | 314 | 55 | 6.5 | 500 | 1.5 | 12 | M6  | AWG6       | 3.1         |
| FN258L-75-34  | 2      | 329             | 220   | 80     | 300     | 314 | 55 | 6.5 | -   | 1.5 | -  | M6  | -          | 4.0         |
| FN258L-100-35 | 2      | 379±1.5         | 220   | 90±0.8 | 350±1.2 | 364 | 65 | 6.5 | -   | 1.5 | -  | M10 | -          | 5.5         |

Note: For CE Marking (EMC Directive) compliant models, contact us for inquiry.



## Output Noise Filter

Base device selection on motor capacity.



[NEC TOKIN Corporation]

Connection Diagram

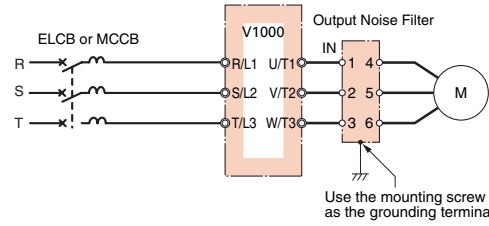

Dimensions (mm)

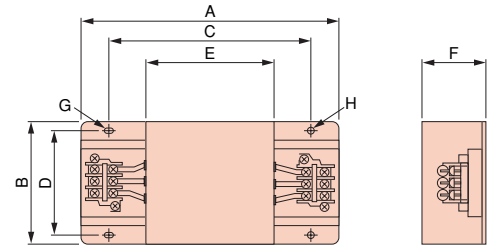

### Three/Single-Phase 200 V Class

| Motor Capacity (kW) | Model    | Code No.  | Qty. | Rated Current (A) | Dimensions (mm) |     |     |     |     |    |        |      | Terminal  | Weight (kg) |
|---------------------|----------|-----------|------|-------------------|-----------------|-----|-----|-----|-----|----|--------|------|-----------|-------------|
|                     |          |           |      |                   | A               | B   | C   | D   | E   | F  | G      | H    |           |             |
| 0.1                 | LF-310KA | FIL000068 | 1    | 10                | 140             | 100 | 100 | 90  | 70  | 45 | 7×φ4.5 | φ4.5 | TE-K5.5M4 | 0.5         |
| 0.2                 | LF-310KA | FIL000068 | 1    | 10                | 140             | 100 | 100 | 90  | 70  | 45 | 7×φ4.5 | φ4.5 | TE-K5.5M4 | 0.5         |
| 0.4                 | LF-310KA | FIL000068 | 1    | 10                | 140             | 100 | 100 | 90  | 70  | 45 | 7×φ4.5 | φ4.5 | TE-K5.5M4 | 0.5         |
| 0.75                | LF-310KA | FIL000068 | 1    | 10                | 140             | 100 | 100 | 90  | 70  | 45 | 7×φ4.5 | φ4.5 | TE-K5.5M4 | 0.5         |
| 1.5                 | LF-310KA | FIL000068 | 1    | 10                | 140             | 100 | 100 | 90  | 70  | 45 | 7×φ4.5 | φ4.5 | TE-K5.5M4 | 0.5         |
| 2.2                 | LF-320KA | FIL000069 | 1    | 20                | 140             | 100 | 100 | 90  | 70  | 45 | 7×φ4.5 | φ4.5 | TE-K5.5M4 | 0.6         |
| 3.7                 | LF-320KA | FIL000069 | 1    | 20                | 140             | 100 | 100 | 90  | 70  | 45 | 7×φ4.5 | φ4.5 | TE-K5.5M4 | 0.6         |
| 5.5                 | LF-350KA | FIL000070 | 1    | 50                | 260             | 180 | 180 | 160 | 120 | 65 | 7×φ4.5 | φ4.5 | TE-K22M6  | 2           |
| 7.5                 | LF-350KA | FIL000070 | 1    | 50                | 260             | 180 | 180 | 160 | 120 | 65 | 7×φ4.5 | φ4.5 | TE-K22M6  | 2           |
| 11                  | LF-350KA | FIL000070 | 2    | 100               | 260             | 180 | 180 | 160 | 120 | 65 | 7×φ4.5 | φ4.5 | TE-K22M6  | 2           |
| 15                  | LF-350KA | FIL000070 | 2    | 100               | 260             | 180 | 180 | 160 | 120 | 65 | 7×φ4.5 | φ4.5 | TE-K22M6  | 2           |
| 18.5                | LF-350KA | FIL000070 | 2    | 100               | 260             | 180 | 180 | 160 | 120 | 65 | 7×φ4.5 | φ4.5 | TE-K22M6  | 2           |

### Three-Phase 400 V Class

| Motor Capacity (kW) | Model    | Code No.  | Qty. | Rated Current (A) | Dimensions (mm) |     |     |     |     |    |        |      | Terminal  | Weight (kg) |
|---------------------|----------|-----------|------|-------------------|-----------------|-----|-----|-----|-----|----|--------|------|-----------|-------------|
|                     |          |           |      |                   | A               | B   | C   | D   | E   | F  | G      | H    |           |             |
| 0.2                 | LF-310KB | FIL000071 | 1    | 10                | 140             | 100 | 100 | 90  | 70  | 45 | 7×φ4.5 | φ4.5 | TE-K5.5M4 | 0.5         |
| 0.4                 | LF-310KB | FIL000071 | 1    | 10                | 140             | 100 | 100 | 90  | 70  | 45 | 7×φ4.5 | φ4.5 | TE-K5.5M4 | 0.5         |
| 0.75                | LF-310KB | FIL000071 | 1    | 10                | 140             | 100 | 100 | 90  | 70  | 45 | 7×φ4.5 | φ4.5 | TE-K5.5M4 | 0.5         |
| 1.5                 | LF-310KB | FIL000071 | 1    | 10                | 140             | 100 | 100 | 90  | 70  | 45 | 7×φ4.5 | φ4.5 | TE-K5.5M4 | 0.5         |
| 2.2                 | LF-310KB | FIL000071 | 1    | 10                | 140             | 100 | 100 | 90  | 70  | 45 | 7×φ4.5 | φ4.5 | TE-K5.5M4 | 0.5         |
| 3.7                 | LF-310KB | FIL000071 | 1    | 10                | 140             | 100 | 100 | 90  | 70  | 45 | 7×φ4.5 | φ4.5 | TE-K5.5M4 | 0.5         |
| 5.5                 | LF-320KB | FIL000072 | 1    | 20                | 140             | 100 | 100 | 90  | 70  | 45 | 7×φ4.5 | φ4.5 | TE-K5.5M4 | 0.6         |
| 7.5                 | LF-320KB | FIL000072 | 1    | 20                | 140             | 100 | 100 | 90  | 70  | 45 | 7×φ4.5 | φ4.5 | TE-K5.5M4 | 0.6         |
| 11                  | LF-335KB | FIL000073 | 1    | 35                | 140             | 100 | 100 | 90  | 70  | 45 | 7×φ4.5 | φ4.5 | TE-K5.5M4 | 0.8         |
| 15                  | LF-335KB | FIL000073 | 1    | 35                | 140             | 100 | 100 | 90  | 70  | 45 | 7×φ4.5 | φ4.5 | TE-K5.5M4 | 0.8         |
| 18.5                | LF-345KB | FIL000074 | 1    | 45                | 260             | 180 | 180 | 160 | 120 | 65 | 7×φ4.5 | φ4.5 | TE-K22M6  | 2           |



## ● Isolator (Insulation Type DC Transmission Converter)



Connection Diagram

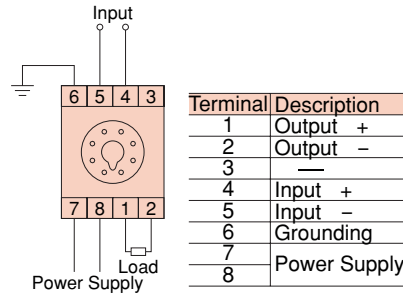

Cable Length

- 4 to 20 mA: within 100 m
- 0 to 10 V: within 50 m

### Dimensions (mm)

Model GP Series

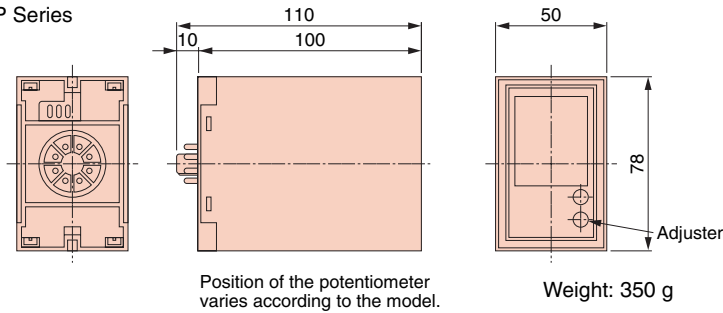

### Socket

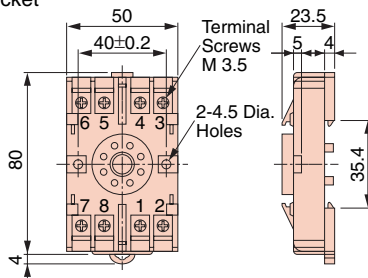

### View of Socket Mounting

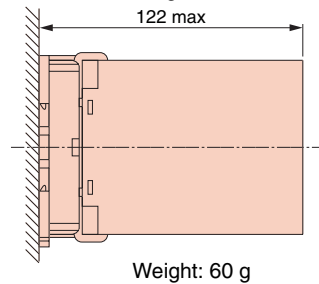

### Performance

- |                                   |  |
|-----------------------------------|--|
| (1) Allowance                     | $\pm 0.25\%$ of output span (ambient temp.: 23°C)                                  |
| (2) Temperature Fluctuation       | $\pm 0.25\%$ of output span (at $\pm 10^\circ\text{C}$ of ambient temperature)     |
| (3) Aux. Power Supply Fluctuation | $\pm 0.1\%$ of output span (at $\pm 10\%$ of aux. power supply)                    |
| (4) Load Resistance Fluctuation   | $\pm 0.05\%$ of output span (in the range of load resistance)                      |
| (5) Output Ripple                 | $\pm 0.5\%$ P-P of output span   |
| (6) Response Time                 | 0.5 s or less (time to settle to $\pm 1\%$ of final steady value)                  |
| (7) Withstand Voltage             | 2000 Vac for 60 s (between all terminals and enclosure)                            |
| (8) Insulation Resistance         | 20 M $\Omega$ and above (using 500 Vdc megger between each terminal and enclosure) |

### Product Line

| Model    | Input Signal | Output Signal | Power Supply | Code No.      |
|----------|--------------|---------------|--------------|---------------|
| DGP2-4-4 | 0 to 10 V    | 0 to 10 V     | 100 Vac      | CON 000019.25 |
| DGP2-4-8 | 0 to 10 V    | 4 to 20 mA    | 100 Vac      | CON 000019.26 |
| DGP2-8-4 | 4 to 20 mA   | 0 to 10 V     | 100 Vac      | CON 000019.35 |
| DGP2-3-4 | 0 to 5 V     | 0 to 10 V     | 100 Vac      | CON 000019.15 |
| DGP3-4-4 | 0 to 10 V    | 0 to 10 V     | 200 Vac      | CON 000020.25 |
| DGP3-4-8 | 0 to 10 V    | 4 to 20 mA    | 200 Vac      | CON 000020.26 |
| DGP3-8-4 | 4 to 20 mA   | 0 to 10 V     | 200 Vac      | CON 000020.35 |
| DGP3-3-4 | 0 to 5 V     | 0 to 10 V     | 200 Vac      | CON 000020.15 |



# Peripheral Devices and Options (continued)

## Braking Resistor, Braking Resistor Unit

Base device selection on motor capacity.

Braking Resistor  
[ERF-150WJ series]



Braking Resistor with Fuse  
[CF120-B579 series]



Built-in

Braking Resistor Unit  
[LKEB series]



Stand-alone



Stand-alone

### Connection Diagram

Set parameter L8-01 to 1 (resistor overheat protection enabled). And, set one of the multi-function digital output terminals (H2-□□) to D (braking resistor fault). With this setting, A sequence in which the power supply will be shut off is required. (When using a braking resistor with fuse, an external sequence is not required)

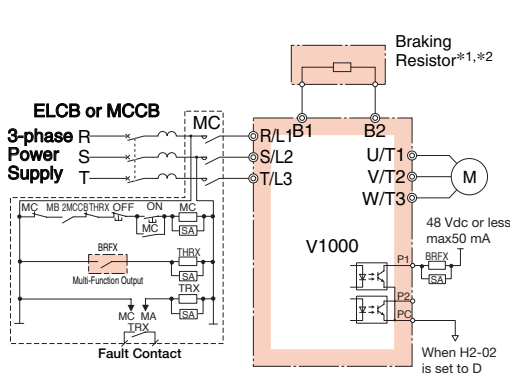

Connection Diagram A

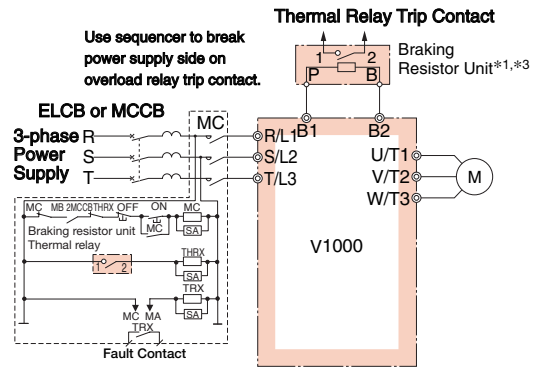

Connection Diagram B

- \*1: Disable Stall Prevention during deceleration by setting L3-04 (Stall Prevention Selection during Deceleration) to 0 (disabled) or 3 (stall prevention with braking resistor) when using a Braking Resistor or Braking Resistor Unit. The motor may not stop within the deceleration time if this setting is not changed.
- \*2: Set L8-01 to 1 to enable braking resistor overload protection in the drive when using ERF-type resistors.
- \*3: Be sure to protect non-Yaskawa braking resistors by thermal overload relay.

- Note: 1. For connections of the separate type braking unit (CDBR type) without using the built-in braking transistor, connect the B1 terminal of the drive to the + terminal of the braking resistor unit and connect the - terminal of the drive to the - terminal of the braking resistor unit. The B2 terminal is not used in this case.
2. Multiple braking resistors should be connected in parallel.

### Dimensions (mm)

#### Braking Resistor

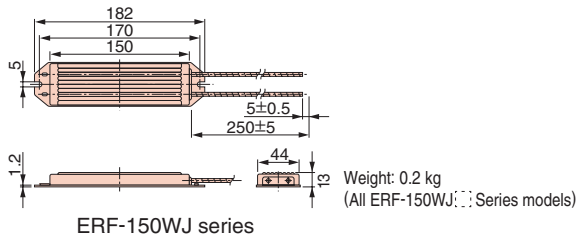

ERF-150WJ series

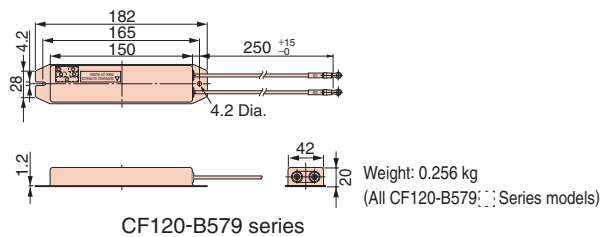

CF120-B579 series

#### Braking Resistor Unit

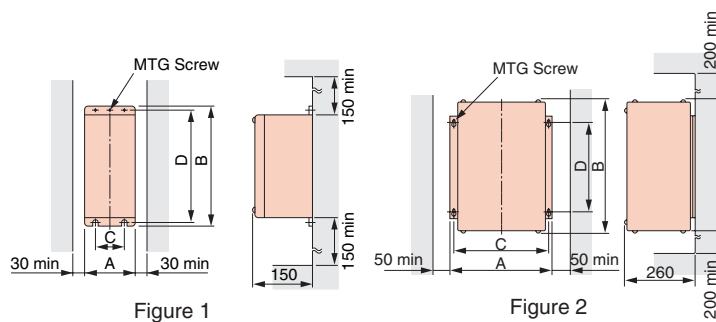

Figure 1

Figure 2

| Braking Resistor Unit Model | Figure | Dimensions (mm) |     |     |     | Weight (kg) | Allowable Average Power Consumption (W) |     |     |
|-----------------------------|--------|-----------------|-----|-----|-----|-------------|---|-----|-----|
|                             |        | A               | B   | C   | D   |             |   |     |     |
| 200 V Class                 | 20P7   | 1               | 105 | 275 | 50  | 260         | M5×3                                    | 3   | 30  |
|                             | 21P5   | 1               | 130 | 350 | 75  | 335         | M5×4                                    | 4.5 | 60  |
|                             | 22P2   | 1               | 130 | 350 | 75  | 335         | M5×4                                    | 4.5 | 89  |
|                             | 23P7   | 1               | 130 | 350 | 75  | 335         | M5×4                                    | 5   | 150 |
|                             | 25P5   | 1               | 250 | 350 | 200 | 335         | M6×4                                    | 7.5 | 220 |
|                             | 27P5   | 1               | 250 | 350 | 200 | 335         | M6×4                                    | 8.5 | 300 |
|                             | 2011   | 2               | 266 | 543 | 246 | 340         | M8×4                                    | 10  | 440 |
| 400 V Class                 | 2015   | 2               | 356 | 543 | 336 | 340         | M8×4                                    | 15  | 600 |
|                             | 40P7   | 1               | 105 | 275 | 50  | 260         | M5×3                                    | 3   | 30  |
|                             | 41P5   | 1               | 130 | 350 | 75  | 335         | M5×4                                    | 4.5 | 60  |
|                             | 42P2   | 1               | 130 | 350 | 75  | 335         | M5×4                                    | 4.5 | 89  |
|                             | 43P7   | 1               | 130 | 350 | 75  | 335         | M5×4                                    | 5   | 150 |
|                             | 45P5   | 1               | 250 | 350 | 200 | 335         | M6×4                                    | 7.5 | 220 |
|                             | 47P5   | 1               | 250 | 350 | 200 | 335         | M6×4                                    | 8.5 | 300 |
|                             | 4011   | 2               | 350 | 412 | 330 | 325         | M6×4                                    | 16  | 440 |
| 4015                        | 2      | 350             | 412 | 330 | 325 | M6×4        | 18                                      | 600 |     |
| 4018                        | 2      | 446             | 543 | 426 | 340 | M8×4        | 19                                      | 740 |     |

## Standard Specifications and Applications

### Three/Single-Phase 200 V Class

| Max. Motor Capacity (kW) | ND/HD | V1000                 |                        | Braking Resistor (Duty Factor: 3% ED, 10 s max.) <sup>*1</sup> |                |      |         |                                  |                  |                |      |         |                                  | Braking Resistor Unit (Duty Factor: 10% ED, 10 s max.) <sup>*1</sup> |                                    |      |         |                                  | Min <sup>*2</sup> Connectable Resistor (Ω) |
|--------------------------|-------|-----------------------|------------------------|--|----------------|------|---------|----------------------------------|------------------|----------------|------|---------|----------------------------------|--|------------------------------------|------|---------|----------------------------------|--|
|                          |       | Three-Phase CIMR-VA2A | Single-Phase CIMR-VABA | No Fuse  |                |      |         |                                  | With Fuse        |                |      |         |                                  | Model LKEB-  | Resistor Specifications (per unit) | Qty. | Diagram | Braking Torque <sup>*3</sup> (%) |  |
|                          |       |                       |                        | Model ERF-150WJ  | Resistance (Ω) | Qty. | Diagram | Braking Torque <sup>*3</sup> (%) | Model CF120-B579 | Resistance (Ω) | Qty. | Diagram | Braking Torque <sup>*3</sup> (%) |  |                                    |      |         |                                  |  |
| 0.1                      | HD    | 0001                  | 0001                   | 401  | 400            | 1    | A       | 220                              | A                | 400            | 1    | A       | 220                              | 40P7   | 70W 750Ω                           | 1    | B       | 220                              | 300  |
| 0.2                      | ND    | 0001                  | 0001                   | 401  | 400            | 1    | A       | 220                              | A                | 400            | 1    | A       | 220                              | 40P7   | 70W 750Ω                           | 1    | B       | 125                              | 300  |
|                          | HD    | 0002                  | 0002                   |  |                |      |         |                                  |                  |                |      |         |                                  |  |                                    |      |         |                                  |  |
| 0.4                      | ND    | 0002                  | 0002                   | 401  | 400            | 1    | A       | 110                              | A                | 400            | 1    | A       | 110                              | 40P7   | 70W 750Ω                           | 1    | B       | 65                               | 300  |
|                          | HD    | 0004                  | 0003                   |  |                |      |         | 201                              | 200              | 220            |      |         | B                                | 200  | 220                                |      |         | 20P7                             | 70W 200Ω                                   |
| 0.75                     | ND    | 0004                  | 0003                   | 201  | 200            | 1    | A       | 125                              | B                | 200            | 1    | A       | 125                              | 20P7   | 70W 200Ω                           | 1    | B       | 125                              | 200  |
|                          | HD    | 0006                  | 0006                   |  |                |      |         |                                  |                  |                |      |         |                                  |  |                                    |      |         | 120                              |  |
| 1.1                      | ND    | 0006                  | 0006                   | 201  | 200            | 1    | A       | 85                               | B                | 200            | 1    | A       | 85                               | 20P7   | 70W 200Ω                           | 1    | B       | 85                               | 120  |
|                          | HD    | 0008                  | —                      |  |                |      |         | 101                              | 100              | 150            |      |         | C                                | 100  | 150                                |      |         | 21P5                             | 260W 100Ω                                  |
| 1.5                      | ND    | 0008                  | —                      | 101  | 100            | 1    | A       | 125                              | C                | 100            | 1    | A       | 125                              | 21P5   | 260W 100Ω                          | 1    | B       | 125                              | 60   |
|                          | HD    | 0010                  | 0010                   |  |                |      |         |                                  |                  |                |      |         |                                  |  |                                    |      |         |                                  |  |
| 2.2                      | ND    | 0010                  | 0010                   | 700  | 70             | 1    | A       | 120                              | D                | 70             | 1    | A       | 120                              | 22P2   | 260W 70Ω                           | 1    | B       | 120                              | 60   |
|                          | HD    | 0012                  | 0012                   |  |                |      |         |                                  |                  |                |      |         |                                  |  |                                    |      |         |                                  |  |
| 3.0                      | ND    | 0012                  | 0012                   | 620  | 62             | 1    | A       | 100                              | E                | 62             | 1    | A       | 100                              | 22P2   | 260W 70Ω                           | 1    | B       | 90                               | 60   |
|                          | HD    | 0018                  | —                      |  |                |      |         |                                  |                  |                |      |         |                                  | 23P7   | 390W 40Ω                           |      |         | 150                              | 32   |
| 3.7                      | ND    | 0018                  | —                      | 620  | 62             | 1    | A       | 80                               | E                | 62             | 1    | A       | 80                               | 23P7   | 390W 40Ω                           | 1    | B       | 125                              | 32   |
|                          | HD    | 0020                  | 0018                   |  |                |      |         |                                  |                  |                |      |         |                                  |  |                                    |      |         |                                  |  |
| 5.5                      | ND    | 0020                  | —                      | —  | —              | —    | —       | —                                | —                | —              | —    | —       | —                                | 23P7   | 390W 40Ω                           | 1    | B       | 85                               | 32   |
|                          | HD    | 0030                  | —                      | —  | —              | —    | —       | —                                | —                | —              | —    | —       | —                                |  |                                    |      |         | 25P5                             | 520W 30Ω                                   |
| 7.5                      | ND    | 0030                  | —                      | —  | —              | —    | —       | —                                | —                | —              | —    | —       | —                                | 27P5   | 780W 20Ω                           | 1    | B       | 125                              | 9.6  |
|                          | HD    | 0040                  | —                      | —  | —              | —    | —       | —                                | —                | —              | —    | —       | —                                |  |                                    |      |         |                                  |  |
| 11                       | ND    | 0040                  | —                      | —  | —              | —    | —       | —                                | —                | —              | —    | —       | —                                | 2011   | 2400W 13.6Ω                        | 1    | B       | 125                              | 9.6  |
|                          | HD    | 0056                  | —                      | —  | —              | —    | —       | —                                | —                | —              | —    | —       | —                                |  |                                    |      |         |                                  |  |
| 15                       | ND    | 0056                  | —                      | —  | —              | —    | —       | —                                | —                | —              | —    | —       | —                                | 2015   | 3000W 10Ω                          | 1    | B       | 125                              | 9.6  |
|                          | HD    | 0069                  | —                      | —  | —              | —    | —       | —                                | —                | —              | —    | —       | —                                |  |                                    |      |         |                                  |  |
| 18.5                     | ND    | 0069                  | —                      | —  | —              | —    | —       | —                                | —                | —              | —    | —       | —                                | 2015   | 3000W 10Ω                          | 1    | B       | 100                              | 9.6  |

### Three-Phase 400 V Class

| Max. Motor Capacity (kW) | ND/HD | V1000                 |  | Braking Resistor (Duty Factor: 3% ED, 10 s max.) <sup>*1</sup> |                |      |         |                                  |                  |                |      |         |                                  | Braking Resistor Unit (Duty Factor: 10% ED, 10 s max.) <sup>*1</sup> |                                    |      |         |                                  | Min <sup>*2</sup> Connectable Resistor (Ω) |
|--------------------------|-------|-----------------------|--|--|----------------|------|---------|----------------------------------|------------------|----------------|------|---------|----------------------------------|--|------------------------------------|------|---------|----------------------------------|--|
|                          |       | Three-Phase CIMR-VA4A |  | No Fuse  |                |      |         |                                  | With Fuse        |                |      |         |                                  | Model LKEB-  | Resistor Specifications (per unit) | Qty. | Diagram | Braking Torque <sup>*3</sup> (%) |  |
|                          |       |                       |  | Model ERF-150WJ  | Resistance (Ω) | Qty. | Diagram | Braking Torque <sup>*3</sup> (%) | Model CF120-B579 | Resistance (Ω) | Qty. | Diagram | Braking Torque <sup>*3</sup> (%) |  |                                    |      |         |                                  |  |
| 0.2                      | HD    | 0001                  |  | 751  | 750            | 1    | A       | 230                              | F                | 750            | 1    | A       | 230                              | 40P7   | 70W 750Ω                           | 1    | B       | 230                              | 750  |
| 0.4                      | ND    | 0001                  |  | 751  | 750            | 1    | A       | 230                              | F                | 750            | 1    | A       | 230                              | 40P7   | 70W 750Ω                           | 1    | B       | 230                              | 750  |
|                          | HD    | 0002                  |  |  |                |      |         |                                  |                  |                |      |         |                                  |  |                                    |      |         |                                  |  |
| 0.75                     | ND    | 0002                  |  | 751  | 750            | 1    | A       | 130                              | F                | 750            | 1    | A       | 130                              | 40P7   | 70W 750Ω                           | 1    | B       | 130                              | 750  |
|                          | HD    | 0004                  |  |  |                |      |         |                                  |                  |                |      |         |                                  |  |                                    |      |         | 510                              |  |
| 1.5                      | ND    | 0004                  |  | 751  | 750            | 1    | A       | 70                               | F                | 750            | 1    | A       | 70                               | 40P7   | 70W 750Ω                           | 1    | B       | 70                               | 510  |
|                          | HD    | 0005                  |  | 401  | 400            |      |         | 125                              | G                | 400            |      |         | 125                              | 41P5   | 260W 400Ω                          |      |         | 125                              | 240  |
| 2.2                      | ND    | 0005                  |  | 301  | 300            | 1    | A       | 115                              | H                | 300            | 1    | A       | 115                              | 42P2   | 260W 250Ω                          | 1    | B       | 135                              | 240  |
|                          | HD    | 0007                  |  |  |                |      |         |                                  |                  |                |      |         |                                  |  |                                    |      |         | 200                              |  |
| 3.0                      | ND    | 0007                  |  | 401  | 400            | 2    | A       | 125                              | J                | 250            | 1    | A       | 100                              | 42P2   | 260W 250Ω                          | 1    | B       | 100                              | 200  |
|                          | HD    | 0009                  |  |  |                |      |         |                                  |                  |                |      |         |                                  | 43P7   | 390W 150Ω                          |      |         | 150                              | 100  |
| 3.7                      | ND    | 0009                  |  | 401  | 400            | 2    | A       | 105                              | J                | 250            | 1    | A       | 83                               | 43P7   | 390W 150Ω                          | 1    | B       | 135                              | 100  |
|                          | HD    | 0011                  |  |  |                |      |         |                                  |                  |                |      |         |                                  |  |                                    |      |         |                                  |  |
| 5.5                      | ND    | 0011                  |  | 201  | 200            | 2    | A       | 135                              | J                | 250            | 2    | A       | 105                              | 45P5   | 520W 100Ω                          | 1    | B       | 135                              | 100  |
|                          | HD    | 0018                  |  | —  | —              |      |         |                                  |                  |                |      |         |                                  |  |                                    |      |         | —                                | —  |
| 7.5                      | ND    | 0018                  |  | —  | —              | —    | —       | —                                | —                | —              | —    | —       | —                                | 47P5   | 780W 75Ω                           | 1    | B       | 130                              | 32   |
|                          | HD    | 0023                  |  | —  | —              | —    | —       | —                                | —                | —              | —    | —       | —                                |  |                                    |      |         |                                  |  |
| 11                       | ND    | 0023                  |  | —  | —              | —    | —       | —                                | —                | —              | —    | —       | —                                | 4011   | 1040W 50Ω                          | 1    | B       | 135                              | 32   |
|                          | HD    | 0031                  |  | —  | —              | —    | —       | —                                | —                | —              | —    | —       | —                                |  |                                    |      |         | 20                               |  |
| 15                       | ND    | 0031                  |  | —  | —              | —    | —       | —                                | —                | —              | —    | —       | —                                | 4015   | 1560W 40Ω                          | 1    | B       | 125                              | 20   |
|                          | HD    | 0038                  |  | —  | —              | —    | —       | —                                | —                | —              | —    | —       | —                                |  |                                    |      |         |                                  |  |
| 18.5                     | ND    | 0038                  |  | —  | —              | —    | —       | —                                | —                | —              | —    | —       | —                                | 4018   | 4800W 32Ω                          | 1    | B       | 125                              | 20   |

\*1: Refers to a motor coasting to stop with a constant torque load. Constant output and regenerative braking will reduce the duty factor.  
 \*2: The braking unit should have a resistance higher than the minimum connectable resistance value and be able to generate enough braking torque to stop the motor.  
 \*3: Applications with a relatively large amount of regenerative power (elevators, hoists, etc.) may require more braking power than is possible with only the standard braking unit and braking resistor. If the braking torque exceeds the value shown in the table, a braking resistor of a higher capacity must be selected.  
 Note: If the built-in fuse on a braking resistor blows, then the entire braking resistor should be replaced.



# Peripheral Devices and Options (continued)

## 24 V Power Supply

The 24 V Power Supply Option maintains drive control circuit power in the event of a main power outage. The control circuit keeps the network communications and I/O data operational in the event of a power outage. It supplies external power to the control circuit only.

Note: Parameter settings can be accessed but cannot be changed when the drive is operating solely from this power supply.



The installed option adds 34 mm to the total depth of the drive.

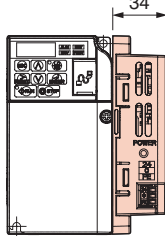

### Connection Diagram

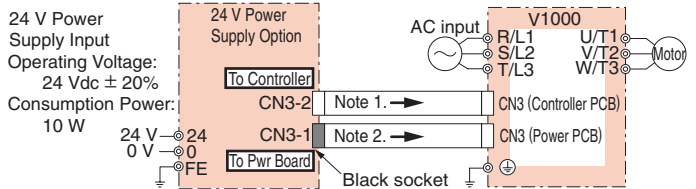

- Note: 1. This cable with "white" connector ends is supplied with the PS-V10M Option.  
 2. This cable with "black" connector ends is supplied with the PS-V10S Option.

The mounting support bracket is required for NEMA Type 1. If these supports are not used, the design is considered "Open Type."

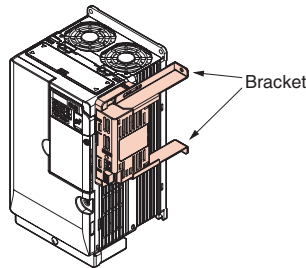

Drive with PS-V10M

| Voltage Class                 | Model<br>CIMR-VA | 24 V Power Supply |             | Bracket     |             |
|-------------------------------|------------------|-------------------|-------------|-------------|-------------|
|                               |                  | Model             | Code No.    | Model       | Code No.    |
| 200 V Class<br>(Three-Phase)  | 2A0001B          | PS-V10S           | 100-038-701 | EZZ020639A  | 100-039-821 |
|                               | 2A0002B          |                   |             |             |             |
|                               | 2A0004B          |                   |             |             |             |
|                               | 2A0006B          |                   |             |             |             |
|                               | 2A0008B          |                   |             |             |             |
|                               | 2A0010B          | PS-V10S           | 100-038-701 | EZZ020639B  | 100-039-822 |
|                               | 2A0012B          |                   |             |             |             |
|                               | 2A0018B          |                   |             |             |             |
|                               | 2A0020B          | PS-V10M           | 100-038-702 | EZZ020639B  | 100-039-822 |
|                               | 2A0030F          |                   |             |             |             |
|                               | 2A0040F          | PS-V10M           | 100-038-702 | EZZ020639C  | 100-039-823 |
| 2A0056F                       |                  |                   |             |             |             |
| 2A0069F                       |                  |                   |             |             |             |
| 200 V Class<br>(Single-Phase) | BA0001B          | PS-V10S           | 100-038-701 | EZZ020639A  | 100-039-821 |
|                               | BA0002B          |                   |             |             |             |
|                               | BA0003B          |                   |             |             |             |
|                               | BA0006B          | PS-V10S           | 100-038-701 | EZZ020639B  | 100-039-822 |
|                               | BA0010B          |                   |             |             |             |
|                               | BA0012B          |                   |             |             |             |
|                               | BA0018B          |                   |             |             |             |
| 400 V Class<br>(Three-Phase)  | 4A0001B          | PS-V10S           | 100-038-701 | EZZ020639A  | 100-039-821 |
|                               | 4A0002B          |                   |             |             |             |
|                               | 4A0004B          |                   |             |             |             |
|                               | 4A0005B          |                   |             |             |             |
|                               | 4A0007B          |                   |             |             |             |
|                               | 4A0009B          | PS-V10S           | 100-038-701 | EZZ020639B  | 100-039-822 |
|                               | 4A0011B          |                   |             |             |             |
|                               | 4A0018F          |                   |             |             |             |
|                               | 4A0023F          | PS-V10M           | 100-038-702 | EZZ020639B  | 100-039-822 |
|                               | 4A0031F          |                   |             |             |             |
| 4A0038F                       | PS-V10M          | 100-038-702       | EZZ020639C  | 100-039-823 |             |

## ● USB Copy Unit (Model: JVOP-181)

Copy parameter settings in a single step, then transfer those settings to another drive.  
Connects to the RJ-45 port on the drive and to the USB port of a PC.

### Connection

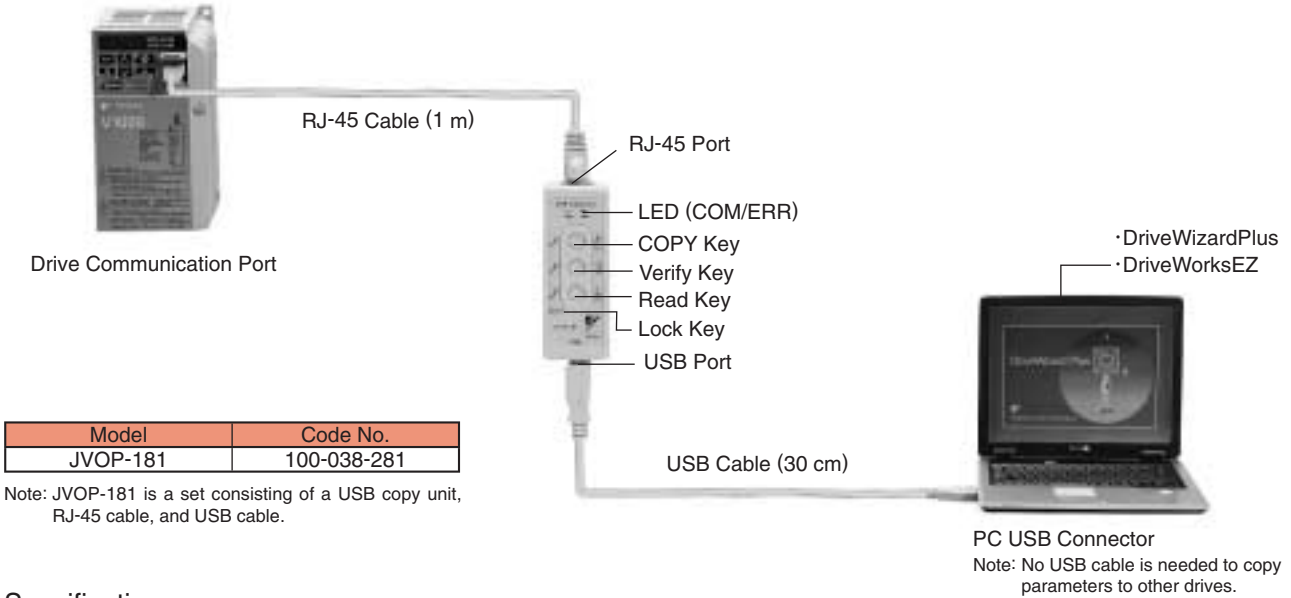

### Specifications

| Item             | Specifications   |
|------------------|--|
| Port             | LAN (RJ-45) : Connect to the drive.<br>USB (Ver.2.0 compatible) : Connect to the PC as required. |
| Power Supply     | Supplied from a PC or the drive  |
| Operating System | Windows2000/XP   |
| Memory           | Memorizes the parameters for one drive.  |
| Dimensions       | 30 (W) × 80 (H) × 20 (D) mm  |
| Included         | RJ-45 cable (1 m), USB cable (30 cm)   |

Note: 1. Drives must have identical software versions to copy parameters settings.  
2. Requires a USB driver available. Contact your YASKAWA representative.  
3. Parameter copy function disabled when connected to a PC.

## ● PC Cable (Model: WV103)

Cable to connect the drive to a PC with DriveWizard Plus or DriveWorksEZ installed.

### Connection

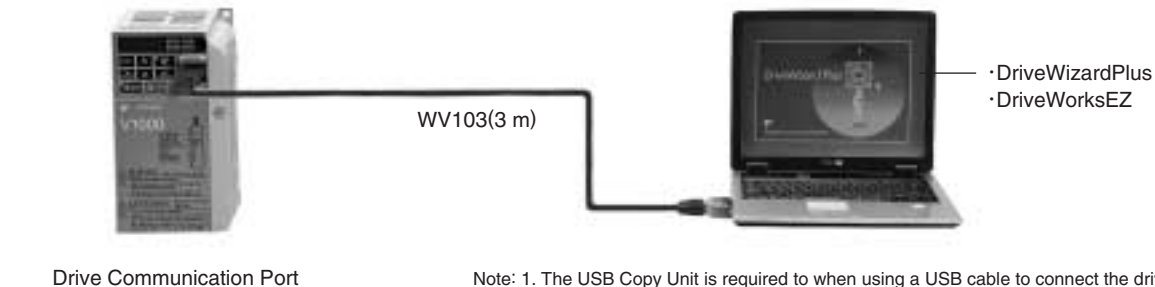

Note: 1. The USB Copy Unit is required to when using a USB cable to connect the drive to a PC.  
2. DriveWizard Plus is a PC software package for managing parameters and functions in Yaskawa drives. To order this software, contact your YASKAWA representative.  
DriveWorksEZ is the software for creating custom application programs for the drive through visual programming. To order this software, contact our sales representative.

| Model | Code No. |
|-------|----------|
| WV103 | WV103    |

### Specifications

| Item         | Specifications |
|--------------|----------------|
| Connector    | DSUB9P         |
| Cable Length | 3 m            |



## Remote Digital Operator / Operator Extension Cable

Allows for remote operation. Includes a Copy function for saving drive settings.

### Connection

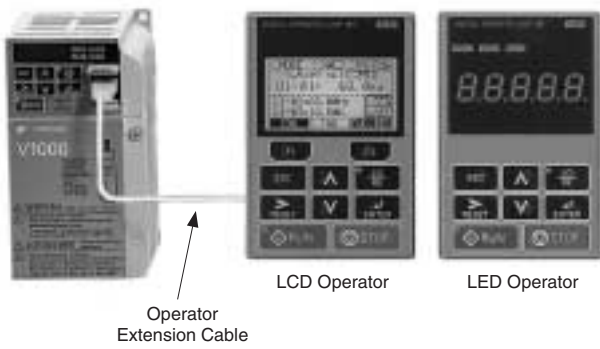

### Dimensions (mm)

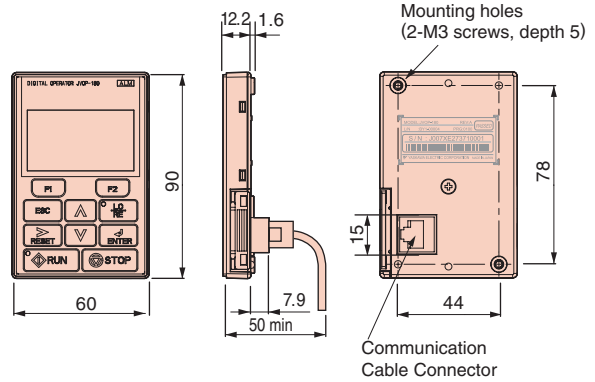

### Remote Digital Operator

| Item         | Model    | Code No.    |
|--------------|----------|-------------|
| LCD Operator | JVOP-180 | 100-041-022 |
| LED Operator | JVOP-182 | 100-043-155 |

### Operator Extension Cable

| Model       | Code No. |
|-------------|----------|
| WV001 (1 m) | WV001    |
| WV003 (3 m) | WV003    |

Note: Never use this cable for connecting the drive to a PC. Doing so may damage the PC.

This bracket is required to mount the LCD or LED operator outside an enclosure panel.

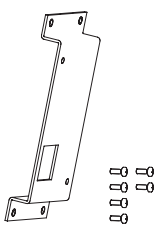
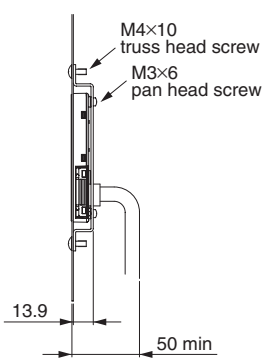
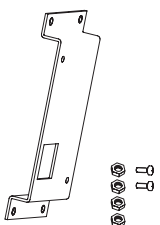
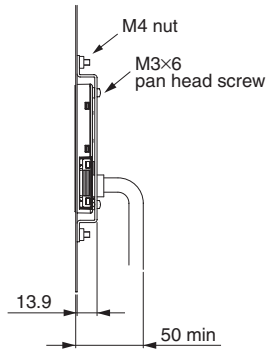
| Item  | Code No. (Model)         | Installation   | Notes                                     |
|---|--------------------------|--|---|
| <br>Installation Support Set A | 100-039-992 (EZZ020642A) | <br>M4×10 truss head screw<br>M3×6 pan head screw<br>13.9<br>50 min | For use with holes through the panel      |
| <br>Installation Support Set B | 100-039-993 (EZZ020642B) | <br>M4 nut<br>M3×6 pan head screw<br>13.9<br>50 min                 | For use with panel mounted threaded studs |

Note: If weld studs are on the back of the panel, use the Installation Support Set B.

## ● Communication Interface Unit



| Name                     | Model   | Code No.    |
|--------------------------|---------|-------------|
| MECHATROLINK-II Option   | SI-T3/V | 100-049-420 |
| MECHATROLINK-III Option* | —       | —           |
| CC-Link Option           | SI-C3/V | 100-038-064 |
| DeviceNet Option         | SI-N3/V | 100-039-409 |
| CompoNet Option          | SI-M3/V | 100-060-128 |
| PROFIBUS-DP Option       | SI-P3/V | 100-038-409 |
| CANopen Option           | SI-S3/V | 100-038-739 |

\*: Available soon

Example of interface installation

### Dimensions (mm)

The interface increases total drive dimensions by 27 mm.

Example: CIMR-VA2A0004

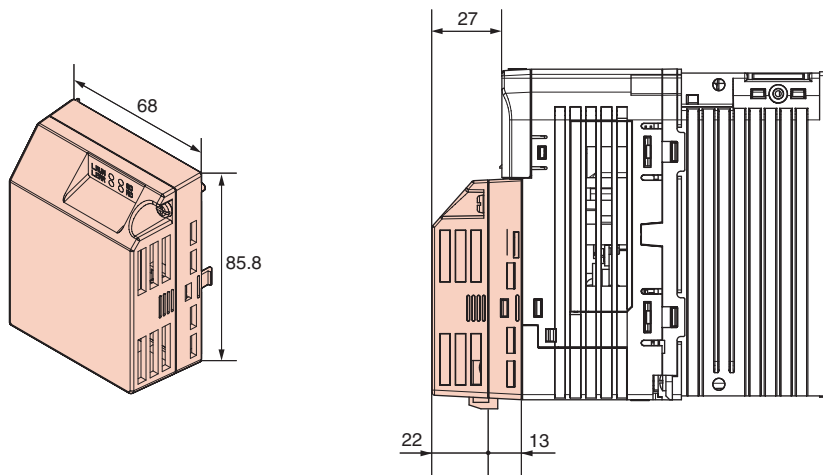



## ● Momentary Power Loss Recovery Unit (0.1 to 7.5 kW for 200 V/400 V class)



| Model              | Code No. |
|--------------------|----------|
| 200 V Class: P0010 | P0010    |
| 400 V Class: P0020 | P0020    |

Note: Use this unit for 7.5kW or less to extend the drive's power loss ride-thru ability to 2 s. When this unit is not used, the drive's power loss ride-thru ability is 0.1 to 1 s.

### Connection Diagram

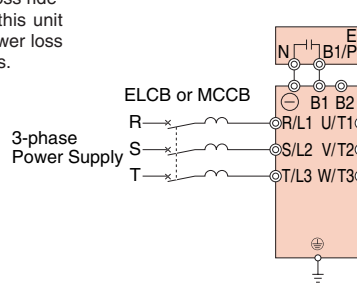

### Dimensions (mm)

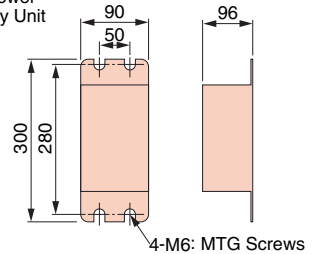

## ● Frequency Meter/Current Meter



| Model                              | Code No.   |
|------------------------------------|------------|
| Scale-75 Hz full-scale: DCF-6A     | FM000065   |
| Scale-60/120 Hz full-scale: DCF-6A | FM000085   |
| Scale-5 A full-scale: DCF-6A       | DCF-6A-5A  |
| Scale-10 A full-scale: DCF-6A      | DCF-6A-10A |
| Scale-20 A full-scale: DCF-6A      | DCF-6A-20A |
| Scale-30 A full-scale: DCF-6A      | DCF-6A-30A |
| Scale-50 A full-scale: DCF-6A      | DCF-6A-50A |

Note: DCF-6A is a 3 V, 1 mA frequency meter. The user may want to additionally install a frequency potentiometer to control output (shown below) or set parameter H4-02 to the appropriate output level (0 to 3 V).

### Dimensions (mm)

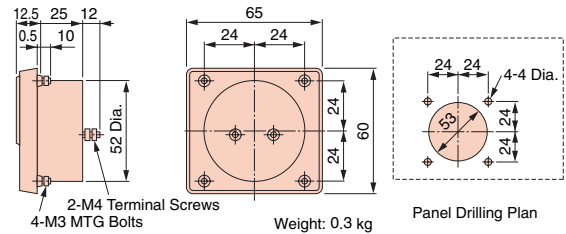

## ● Frequency Setting Potentiometer/Frequency Meter Adjusting Potentiometer



| Model           | Code No. |
|-----------------|----------|
| RV30YN20S 2 kΩ  | RH000739 |
| RV30YN20S 20 kΩ | FM000850 |

### Dimensions (mm)

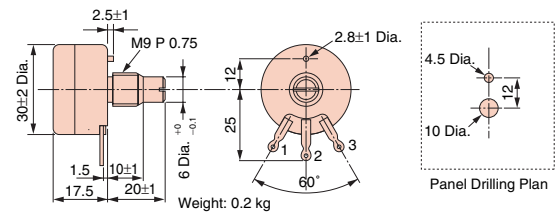

## ● Control Dial for Frequency Setting Potentiometer/Frequency Meter Adjusting Potentiometer



| Model | Code No.  |
|-------|-----------|
| CM-3S | HLNZ-0036 |

### Dimensions (mm)

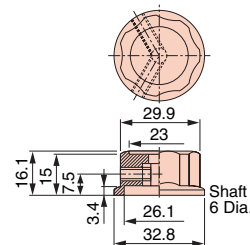

## ● Meter Plate for Frequency Setting Potentiometer/Frequency Meter Adjusting Potentiometer



| Model       | Code No.    |
|-------------|-------------|
| NPJT41561-1 | NPJT41561-1 |

### Dimensions (mm)

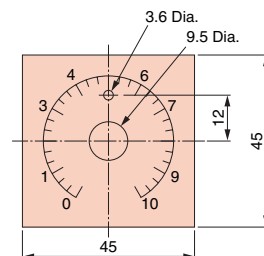



## Output Voltage Meter



| Model   | Code No. |
|---|----------|
| Scale-300 V full-scale (Rectification Type Class 2.5)<br>: SCF-12NH | VM000481 |
| Scale-600 V full-scale (Rectification Type Class 2.5)<br>: SCF-12NH | VM000502 |

### Dimensions (mm)

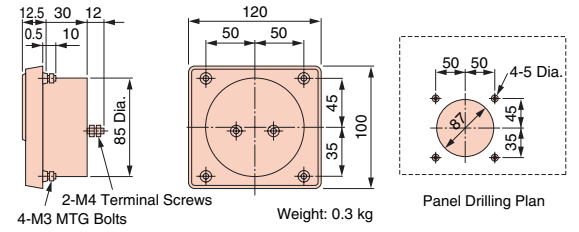

## Potential Transformer

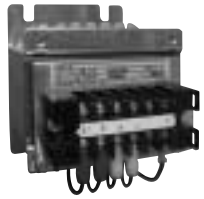

| Model  | Code No.    |
|--|-------------|
| 600 V meter for voltage transformer<br>UPN-B 440/110 V (400/100 V) | 100-011-486 |

\*: For use with a standard voltage regulator.  
A standard voltage regulator may not match the drive output voltage. Select a regulator specifically designed for the drive output (100-011-486), or a voltmeter that does not use a transformer and offers direct read out.

### Dimensions (mm)

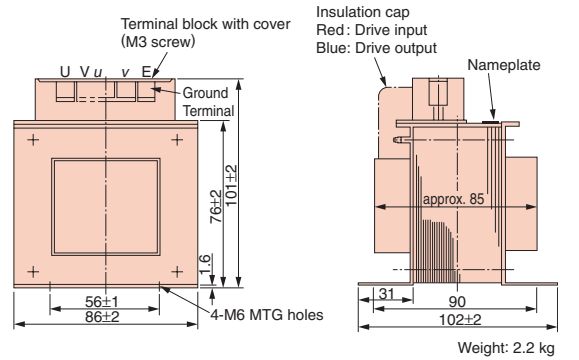



## Application Notes

### Selection

#### ■ Installing a Reactor

An AC or DC reactor can be used for the following:

- to suppress harmonic current.
- to smooth peak current that results from capacitor switching.
- when the power supply is above 600 kVA.
- Use an AC reactor when also connecting a thyristor converter to the

same power supply system, regardless of the conditions of the power supply.

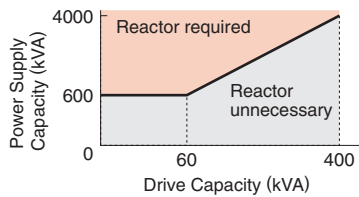

#### ■ Drive Capacity

Make sure that the motor's rated current is less than the drive's output current. When running a specialized motor or more than one motor in parallel from a single drive, the capacity of the drive should be larger than 1.1 times of the total motor rated current.

#### ■ Starting Torque

The overload rating for the drive determines the starting and accelerating characteristics of the motor. Expect lower torque than when running from line power. To get more starting torque, use a larger drive or increase both the motor and drive capacity.

#### ■ Emergency Stop

When the drive faults out, a protective circuit is activated and drive output is shut off. This, however, does not stop the motor immediately. Some type of mechanical brake may be needed if it is necessary to halt the motor faster than the Fast Stop function is able to.

#### ■ Options

She B1, B2, -, +1, and +2 terminals are used to connect optional devices. Connect only V1000-compatible devices.

#### ■ Repetitive Starting/Stopping

Cranes (Hoists), elevators, punching presses, and other such applications with frequent starts and stops often exceed 150% of their rated current values. Heat stress generated from repetitive high current can shorten the lifespan of the IGBTs. The expected lifespan for the IGBTs is about 8 million start and stop cycles with a 4 kHz carrier frequency and a 150% peak current.

Yaskawa recommends lowering the carrier frequency, particularly when audible noise is not a concern. The user can also choose to reduce the load, increase the acceleration and deceleration times, or switch to a larger drive. This will help keep peak current levels under 150%.

Be sure to check the peak current levels when starting and stopping repeatedly during the initial test run, and make adjustments accordingly.

For crane-type applications taking the inching function in which the motor is quickly started and stopped, Yaskawa recommends the following to ensure motor torque levels and lower the drive:

- Select a large enough drive so that peak current levels remain below 150%.
- The drive should be one frame size larger than the motor.

### Installation

#### ■ Enclosure Panels

Keep the drive in a clean environment by either selecting an area free of airborne dust, lint, oil mist, corrosive gas, and flammable gas, or install the drive in an enclosure panel. Leave the required space between the drives to provide for cooling, and take steps to ensure that the ambient temperature remains within allowable limits. Keep flammable materials away from the drive. If the drive must be used in an area where it is subjected to oil mist and excessive vibration, protective designs are available. Contact Yaskawa for details.

#### ■ Installation Direction

The drive should be installed upright as specified in the manual.

### Settings

■ If using Open Loop Vector Control designed for permanent magnet motors, make sure that the proper motor code has been set to parameter E5-01 before performing a trial run.

#### ■ Upper Limits

Because the drive is capable of running the motor at up to 400 Hz, be sure to set the upper limit for the frequency to control the maximum speed. The default setting for the maximum output frequency is 60 Hz.

#### ■ DC Injection Braking

Motor overheat can result if there is too much current used during DC Injection Braking, or if the time for DC Injection Braking is too long.

#### ■ Acceleration/Deceleration Times

Acceleration and deceleration times are affected by how much torque the motor generates, the load torque, and the inertia moment ( $GD^2/4$ ). Set a longer accel/decel time when Stall Prevention is enabled. The accel/decel times are lengthened for as long as the Stall Prevention function is operating. For faster acceleration and deceleration, increase the capacity of the drive.

### Compliance with Harmonic Suppression Guidelines

V1000 conforms to strict guidelines in Japan covering harmonic suppression for power conversion devices. Defined in JEM-TR201 and JEM-TR226 and published by the Japan Electrical Manufacturers' Association, these guidelines define the amount of harmonic current output acceptable for new installation. Contact your YASKAWA representative.

### General Handling

#### ■ Wiring Check

Never short the drive output terminals or apply voltage to output terminals (U/T1, V/T2, W/T3), as this can cause serious damage to the drive. Doing so will destroy the drive. Be sure to perform a final check of all sequence wiring and other connections before turning the power on. Make sure there are no short circuits on the control terminals (+V, AC, etc.), as this could damage the drive.

#### ■ Magnetic Contactor Installation

Avoid switching a magnetic contactor on the power supply side more frequently than once every 30 minutes. Frequent switching can cause damage to the drive.

#### ■ Inspection and Maintenance

After shutting off the drive, make sure the CHARGE light has gone out completely before performing any inspection or maintenance. Residual voltage in drive capacitors can cause serious electric shock.

The heatsink can become quite hot during operation, and proper precautions should be taken to prevent burns. When replacing the cooling fan, shut off the power and wait at least 15 minutes to be sure that the heatsink has cooled down.

#### ■ Transporting the Drive

Never steam clean the drive.

During transport, keep the drive from coming into contact with salts, fluorine, bromine and other such harmful chemicals.

## ● Peripheral Devices

#### ■ Installing a Ground Fault Interrupter or an MCCB

Install an MCCB or a ground fault interrupter recommended by Yaskawa to the power supply side of the drive to protect internal circuitry. The type of MCCB needed depends on the power supply power factor (power supply voltage, output frequency, load characteristics, etc.). Sometimes a fairly large MCCB may be required due to the affects of harmonic current on operating characteristics. Those using a ground fault interrupter other than those recommended in this catalog, use one

fitted for harmonic suppression measures (one designed specifically for drives). The rated current of the ground fault interrupter must be 200 mA or higher per drive unit. Select an MCCB with a rated capacity greater than the short-circuit current for the power supply. For a fairly large power supply transformer, a fuse can be added to the ground fault interrupter or MCCB in order to handle the short-circuit current level.

#### ■ Magnetic Contactor for Input Power

Use a magnetic contactor (MC) to ensure that power to the drive can be completely shut off when necessary. The MC should be wired so that it opens when a fault output terminal is triggered.

Even though an MC is designed to switch following a momentary power loss, frequent MC use can damage other components. Avoid switching the MC more than once every 30 minutes. The MC will not be activated after a momentary power loss if using the operator keypad to run the drive. This is because the drive is unable to restart automatically when set for LOCAL. Although the drive can be stopped by using an MC installed on the power supply side, the drive cannot stop the motor in a controlled fashion, and it will simply coast to stop. If a braking resistor or dynamic braking unit has been installed, be absolutely sure to set up a sequence that opens the MC with a thermal protector switch connected to the braking resistor device.

#### ■ Magnetic Contactor for Motor

As a general principle, the user should avoid opening and closing the magnetic contactor between the motor and the drive during run. Doing so can cause high peak currents and overcurrent faults. If magnetic contactors are used to bypass the drive by connecting the motor to the power supply directly, make sure to close the bypass only after the drive is stopped and fully disconnected from the motor. The Speed Search function can be used to start a coasting motor.

Use an MC with delayed release if momentary power loss is a concern.

#### ■ Motor Thermal Over Load Relay Installation

Although the drive comes with built in electrothermal protection to prevent damage from overheat, a thermal relay should be connected between the drive and each motor if running several motors from the same drive. For a multipole motor or some other type of non-standard motor, Yaskawa recommends using an external thermal relay appropriate for the motor. Be sure to disable the motor protection selection parameter (L1-01 = 0), and set the thermal relay or thermal protection value to 1.1 times the motor rated current listed on the motor nameplate.



When a high carrier frequency and long motor cables are used, nuisance tripping of the thermal relay may occur due to increased leakage current. To avoid this, reduce the carrier frequency or increase the tripping level of the thermal overload relay.

### ■ Improving the Power Factor

Installing a DC or AC reactor to the input side of the drive can help improve the power factor.

Refrain from using a capacitor or surge absorber on the output side as a way of improving the power factor, because harmonic contents on the output side can lead to damage from overheat. This can also lead to problems with overcurrent.

### ■ Radio Frequency Interference

Drive output contains harmonic contents that can affect the performance of surrounding electronic instruments such as an AM radio. These problems can be prevented by installing a noise filter, as well as by using a properly grounded metal conduit to separate wiring between the drive and motor.

### ■ Wire Gauges and Wiring Distance

Motor torque can suffer as a result of voltage loss across a long cable running between the drive and motor, especially when there is low frequency output. Make sure that a large enough wire gauge is used.

The optional LCD operator requires a proprietary cable to connect to the drive. If an analog signal is used to operate the drive via the input terminals, make sure that the wire between the analog operator and the drive is no longer than 50 m, and that it is properly separated from the main circuit wiring. Use reinforced circuitry (main circuit and relay sequence circuitry) to prevent inductance from surrounding devices. To run the drive with a frequency potentiometer via the external terminals, use twisted shielded pair cables and ground the shield.

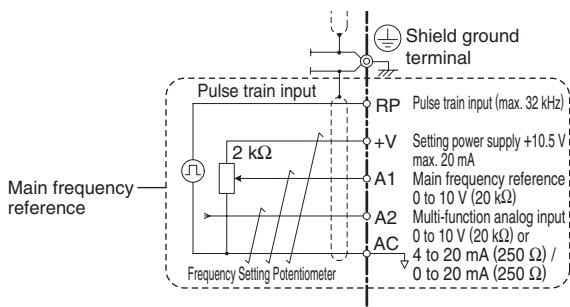

### ■ Counteracting Noise

Because V1000 is designed with PWM control, a low carrier frequency tends to create more motor flux noise than using a higher carrier frequency. Keep the following point in mind when considering how to reduce motor noise:

- Lowering the carrier frequency (C6-02) minimizes the effects of noise.
- A line noise filter can be effective in reducing the affects on AM radio frequencies and poor sensor performance. See "Options and Peripheral Devices" on page 28.
- Make sure the distance between signal and power lines is at least 10 cm (up to 30 cm is preferable), and use twisted pair cable to prevent induction noise form the drive power lines.

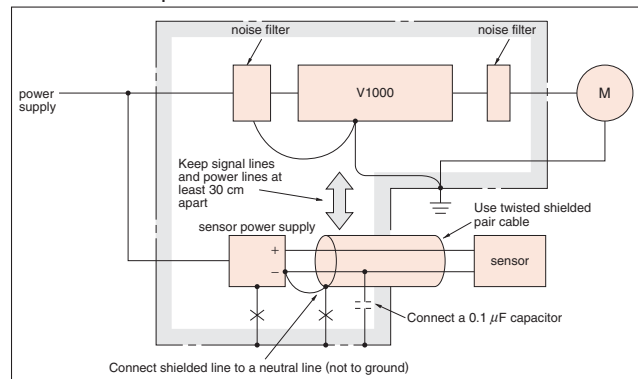

<Provided by JEMA>

### ■ Leakage Current

Harmonic leakage current passes through stray capacitance that exists between the power lines to the drive, ground, and the motor lines. Consider using the following peripheral devices to prevent problems with leakage current.

|                               | Problem   | Solution  |
|-------------------------------|---|---|
| Ground Leakage Current        | MCCB is mistakenly triggered  | <ul style="list-style-type: none"> <li>• Lower the carrier frequency set to parameter C6-02.</li> <li>• Try using a component designed to minimize harmonic distortion for the MCCB such as the NV series by Mitsubishi.</li> </ul> |
| Current Leakage Between Lines | Thermal relay connected to the external terminals is mistakenly triggered by harmonics in the leakage current | <ul style="list-style-type: none"> <li>• Lower the carrier frequency set to parameter C6-02.</li> <li>• Use the drive's built-in thermal motor protection function.</li> </ul>  |

The following table shows the guidelines for the set value of the carrier frequency relative to the wiring distance between the drive and the motor when using V/f control.

When Open Loop Vector Control or PM Open Loop Vector Control is used and the wiring distance is 50 m to 100 m, set the carrier frequency to 2 kHz.

| Wiring Distance*                   | 50 m or less               | 100 m or less                   | Greater than 100 m           |
|------------------------------------|----------------------------|---------------------------------|------------------------------|
| C6-02: Carrier Frequency Selection | 1 to Auto (15 kHz or less) | 1, 2, 7 to Auto (5 kHz or less) | 1, 7 to Auto (2 kHz or less) |

\*: When a single drive is used to run multiple motors, the length of the motor cable should be calculated as the total distance between the drive and each motor.

When the wiring distance exceeds 100 m, use the drive observing the following conditions.

- Select V/f control mode (A1-02=0)
- To start a coasting motor
  - a) Use the current detection type (b3-24=0) when using the speed search function, or
  - b) Set the DC injection braking time at start (b2-03=0.01 to 10.00 sec) to stop a coasting motor and restart it.

More than one synchronous motor cannot be connected to a single drive. The maximum wiring distance between the drive and the synchronous motor must be 100 m.

## ● Notes on Motor Operation

### Using a Standard Motor

#### ■ Low Speed Range

There is a greater amount of loss when operating a motor using an drive than when running directly from line power. With a drive, the motor can become quite hot due to the poor ability to cool the motor at low speeds. The load torque should be reduced accordingly at low speeds. The figure above shows the allowable load characteristics for a Yaskawa standard motor. A motor designed specifically for operation with a drive should be used when 100% continuous torque is needed at low speeds.

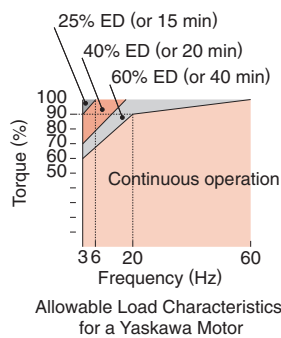

#### ■ Insulation Tolerance

Consider voltage tolerance levels and insulation in applications with an input voltage of over 440 V or particularly long wiring distances.

#### ■ High Speed Operation

Problems may occur with the motor bearings and dynamic balance in applications operating at over 60 Hz. Contact Yaskawa for consultation.

#### ■ Torque Characteristics

Torque characteristics differ when operating directly from line power. The user should have a full understanding of the load torque characteristics for the application.

#### ■ Vibration and Shock

V1000 lets the user choose between high carrier PWM control and low carrier PWM. Selecting high carrier PWM can help reduce motor oscillation. Keep the following points in mind when using high carrier PWM:

##### (1) Resonance

Take particular caution when using a variable speed drive for an application that is conventionally run from line power at a constant speed. Shock-absorbing rubber should be installed around the

base of the motor and the Jump Frequency selection should be enabled to prevent resonance.

- (2) Any imperfection on a rotating body increases vibration with speed

Caution should be taken when operating above the motor rated speed.

#### ■ Audible Noise

Noise created during run varies by the carrier frequency setting. Using a high carrier frequency creates about as much noise as running from line power. Operating above the rated r/min (i.e., above 60 Hz), however, can create unpleasant motor noise.

### Using a Synchronous Motor

■ Please contact us for consultation when using a synchronous motor not already approved by Yaskawa.

■ Even when the power has been shut off for a drive running a PM motor, voltage continues to be generated at the motor terminals while the motor coasts to stop. Take the precautions described below to prevent shock and injury:

- Applications where the machine can still rotate even though the drive has fully stopped should have a low voltage manual load switch installed to the output side of the drive. (Yaskawa recommends the AICUT LB Series by AICHI Electric Works Co., Ltd.)
- Do not apply to a load that could potentially rotate the motor faster than the maximum allowable r/min even when the drive has been shut off.
- Wait at least one minute after opening the low voltage manual load switch on the output side before inspecting the drive or performing and maintenance.
- Do not open a close the low voltage manual load switch while the motor is running, as this can damage the drive.
- To close the low voltage manual load switch connected to a coasting motor, first turn on the power to the drive and make sure that the drive has stopped.

■ Synchronous motors cannot be started directly from line power. Applications that requiring line power to start should use an induction motor with the drive.

■ A single drive is not capable of running multiple synchronous motors at the same time. Use a standard induction motor for such setups.

■ At start, a synchronous motor may rotate slightly in the opposite direction of the Run command depending on parameter settings and motor type.

■ Uses derated torque of 50% less than starting torque. Set up the motor with the drive after verifying the



starting torque, allowable load characteristics, impact load tolerance, and speed control range.

- Even with a braking resistor, braking torque is less than 125% when running between 20% to 100% speed, and falls to less than half the braking torque when running at less than 20% speed.
- There is no torque control available, and torque limits cannot be set. Consequently, synchronous motors are not appropriate for applications that operate at low speeds (less than 10% of the rated speed) or experience sudden changes in speed. Such applications are better suited for induction motors or servo drives.
- The allowable load inertia moment is 50 times less than the motor inertia moment. Contact Yaskawa concerning applications with a larger inertia moment.
- When using a holding brake, release the brake prior to starting the motor. Failure to set the proper timing can result in speed loss. Not for use with conveyor, transport, or hoist type applications.
- To restart a coasting motor rotating at over 120 Hz, use the Short Circuit Braking\* function to first bring the motor to a stop. Short Circuit Braking requires a special braking resistor.  
Speed Search can be used to restart a coasting motor rotating slower than 120 Hz. If the motor cable is relatively long, however, the motor should instead be stopped using Short Circuit Braking and then restarted.

\*: Short Circuit Braking creates a short-circuit in the motor windings to forcibly stop a coasting motor.

## ● Applications with Specialized Motors

- **Multi-pole Motor**  
Because the rated current will differ from a standard motor, be sure to check the maximum current when selecting a drive. Always stop the motor before switching between the number of motor poles. If a regenerative overvoltage fault occurs or if overcurrent protection is triggered, the motor will coast to stop.
- **Submersible Motor**  
Because motor rated current is greater than a standard motor, select the drive capacity accordingly. Be sure to use a large enough motor cable to avoid decreasing the maximum torque level on account of voltage drop caused by a long motor cable.

### ■ Explosion-proof Motor

Both the motor and drive need to be tested together to be certified as explosion-proof. The drive is not for explosion proof areas.

### ■ Geared Motor

Continuous operation specifications differ by the manufacturer of the lubricant. Due to potential problems of gear damage when operating at low speeds, be sure to select the proper lubricant. Consult with the manufacturer for applications that require speeds greater than the rated speed range of the motor or gear box.

### ■ Single-phase Motor

Variable speed drives are not designed for operating single phase motors. Using a capacitor to start the motor causes excessive current to flow into the capacitors, potentially causing damage. A split-phase start or a repulsion start can end up burning out the starter coils because the internal centrifugal switch is not activated. V1000 is for use only with 3-phase motors.

### ■ Uras Vibrator

Uras vibrator is a vibration motor that gets power from centrifugal force by rotating unbalanced weights on both ends of the shaft. Make the following considerations when selecting a drive for use with an Uras vibrator:

- (1) Uras vibrator should be used within the drive rated frequency
- (2) Use V/f Control
- (3) Increase the acceleration time five to fifteen times longer than would normally be used due to the high amount of load inertia of an Uras vibrator  
Note: A drive with a different capacity must be selected if the acceleration time is less than 5 s.
- (4) Drive may have trouble starting due to undertorque that results from erratic torque (static friction torque at start)

### ■ Motor with Brake

Caution should be taken when using a drive to operate a motor with a built-in holding brake. If the brake is connected to the output side of the drive, it may not release at start due to low voltage levels. A separate power supply should be installed for the motor brake. Motors with a built-in brake tend to generate a fair amount of noise when running at low speeds.

### Power Driven Machinery (decelerators, belts, chains, etc.)

Continuous operation at low speeds wears on the lubricating material used in gear box type systems to accelerate and decelerate power driven machinery. Caution should also be taken when operating at speeds above the rated machine speed due to noise and shortened performance life.



# YASKAWA AC Drive Series

| Name  | Feature   | Capacity Range (kW)      |   | Outline  |   |
|---|---|--------------------------|---|--|---|
|   |   | 0.1                      | 1 10 100 300 630  |  |   |
| General Purpose   | J1000<br>Compact V/f Control AC Drive   | Three-Phase 200 V Class  | 0.1  5.5  | <ul style="list-style-type: none"> <li>Ultra-small body enables side-by-side installation. Compact design of enclosure panel</li> <li>Easy operation with the Potentiometer Option Unit</li> <li>The noise-suppressing Swing PWM system reduces harsh sound.</li> <li>The full-range fully-automatic torque boost function provides high torque output. (100%/1.5 Hz, 150%/3 Hz)</li> <li>The Stall Prevention function and the momentary power loss ride-thru ensure continuous operation, regardless of load/power supply fluctuations or momentary power loss.</li> <li>The Overexcitation braking function enables rapid braking, without using a braking resistor.</li> </ul> |   |
|   |   | Single-Phase 200 V Class | 0.1  2.2  |  |   |
|   |   | Three-Phase 400 V Class  | 0.2  5.5  |  |   |
|   | V1000<br>Compact Vector Control AC Drive  | Three-Phase 200 V Class  | 0.1  18.5   |  | <ul style="list-style-type: none"> <li>Small body and high performance (Current vector control)</li> <li>New technology for driving synchronous motors (IPMM/SPMM) as well as induction motors</li> <li>High starting torque: 200%/0.5 Hz*<br/>Torque limit function<br/>* At Heavy Duty rating, for induction motors with 3.7 kW or lower</li> <li>Application-specific function selection for simplified optimum setup</li> <li>Easy maintenance using the detachable terminal block with the parameter backup function</li> </ul>  |
|   |   | Single-Phase 200 V Class | 0.1  3.7  |  |   |
|   |   | Three-Phase 400 V Class  | 0.2  18.5   |  |   |
|   | A1000<br>Advanced Vector Control AC Drive   | Three-Phase 200 V Class  | 0.4  110  | <ul style="list-style-type: none"> <li>New technology for driving synchronous motors (IPMM/SPMM) as well as induction motors</li> <li>High starting torque IPM motor without a motor encoder: 0 r/min 200% torque</li> <li>Application preset function selection for simplified optimum setup</li> <li>Easy maintenance using the detachable terminal block with the parameter backup function</li> </ul>  |   |
|   |   | Three-Phase 400 V Class  | 0.4  630  |  |   |
|   | Varispeed G7<br>General-purpose Inverter With Advanced Vector Control Minimal Noise | Three-Phase 200 V Class  | 0.4  110  |  |   |
|   |   | Three-Phase 400 V Class  | 0.4  300  |  |   |
|   | Varispeed AC<br>Environmentally Friendly Motor Drives Matrix Converter              | Three-Phase 200 V Class  | 5.5  45   | <ul style="list-style-type: none"> <li>The world's first matrix converter system that outputs AC voltage from AC voltage, and includes power supply regeneration capabilities.</li> <li>The simple, highly-efficient drive can remarkably reduce power supply harmonics, without using peripherals.</li> </ul>   |   |
|   |   | Three-Phase 400 V Class  | 5.5  75   |  |   |
| ECOiPM Drive<br>Compact and Energy Efficiency Drives        | Three-Phase 200 V Class   | 0.4  15                  | <ul style="list-style-type: none"> <li>Grade higher than IE3 efficiency class saves energy during operation.</li> <li>V1000 drives combined with compact ECOiPM motors make more compact and lighter drive systems.</li> <li>Less maintenance because bearing grease life is approx. three times longer compared to use with induction motors.</li> <li>Improved reliability with elimination of an encoder of precision device.</li> </ul> |  |   |
|   | Three-Phase 400 V Class   | 0.4  15                  |   |  |   |
| V1000pico Drive<br>Super Compact and Environmentally Drives | Three-Phase 200 V Class   | 0.1  3.7                 |   | <ul style="list-style-type: none"> <li>V1000 drives combined with super compact V1000pico motors make more compact and lighter drive systems.</li> <li>Applicable in locations subject to water jets or abrasive powder with its protective enclosure rated IP65 or higher.</li> <li>Improved reliability with elimination of an encoder of precision device.</li> <li>Use of V1000 drives, which can control not only induction motors but also synchronous motors, brings the uniformity of your stock.</li> </ul>   |   |
| Special Use   | L1000A<br>Elevator Applications   | Three-Phase 200 V Class  |   | 1.5  110 *   | <ul style="list-style-type: none"> <li>Cutting-edge drive technology allows L1000A to run a newly installed gearless synchronous motor, or a refurbished geared induction motor. This minimizes equipment required for your application.</li> <li>Interfaces to match gearless, synchronous motors and every type of absolute encoder.</li> <li>Even without a load sensor, high-performance torque compensation and high-resolution absolute encoder eliminate rollback when the brake is released.</li> <li>Output interrupt Satisfies safety requirements and Ensures a reliable elevator system.</li> <li>Rescue Operation switches to backup battery or UPS in case of a power outage.</li> <li>All standard models are compliant with the Europe's RoHS directive.</li> </ul> |
|   |   | Three-Phase 400 V Class  | 1.5  110 *  |  |   |
|   | VS-646HF5<br>High-frequency Inverter Drives   | Three-Phase 200 V Class  | 2.2  7.5  | <ul style="list-style-type: none"> <li>Provides a high rotation speed of 420,000 r/min in combination with a high-speed (2-pole) motor</li> </ul>  |   |

\* Some models not yet available.



# Global Service Network



| Region        | Service Area         | Service Location   | Service Agency   | Telephone/Fax   |
|---------------|----------------------|--|--|---|
| North America | U.S.A.               | Chicago (HQ)<br>Los Angeles<br>San Francisco<br>New Jersey<br>Boston<br>Ohio<br>North Carolina | ① YASKAWA AMERICA INC.   | Headquarters<br>☎ +1-847-887-7000<br>FAX +1-847-887-7370                    |
|               | Mexico               | Mexico City  | ② PILLAR MEXICANA. S.A. DE C.V.                                  | ☎ +52-555-660-5553<br>FAX +52-555-651-5573                                  |
| South America | South America        | São Paulo  | ③ YASKAWA ELÉTRICO DO BRASIL LTD.A.                              | ☎ +55-11-3585-1100<br>FAX +55-11-5581-8795                                  |
|               | Colombia             | Bogota   | ④ VARIADORES LTD.A.  | ☎ +57-1-428-4225<br>FAX +57-1-428-2173                                      |
| Europe        | Europe, South Africa | Frankfurt  | ⑤ YASKAWA EUROPE GmbH  | ☎ +49-6196-569-300<br>FAX +49-6196-569-398                                  |
| Asia          | Japan                | Tokyo, offices nationwide  | ⑥ YASKAWA ELECTRIC CORPORATION (Manufacturing, sales)            | ☎ +81-3-5402-4502<br>FAX +81-3-5402-4580                                    |
|               |                      |  | ⑦ YASKAWA ELECTRIC ENGINEERING CORPORATION (After-sales service) | ☎ +81-4-2931-1810<br>FAX +81-4-2931-1811                                    |
|               | South Korea          | Seoul  | ⑧ YASKAWA ELECTRIC KOREA CORPORATION                             | ☎ +82-2-784-7844<br>FAX +82-2-784-8495                                      |
|               |                      |  | ⑨ YASKAWA ENGINEERING KOREA Co.                                  | ☎ +82-2-3775-0337<br>FAX +82-2-3775-0338                                    |
|               | China                | Beijing, Guangzhou, Shanghai   | ⑩ YASKAWA ELECTRIC CHINA Co., Ltd.                               | ☎ +86-21-5385-2200<br>FAX +86-21-5385-3299                                  |
|               | Taiwan               | Taipei   | ⑪ YASKAWA ELECTRIC TAIWAN Co.                                    | ☎ +886-2-2502-5003<br>FAX +886-2-2505-1280                                  |
|               | Singapore            | Singapore  | ⑫ YASKAWA ELECTRIC (SINGAPORE) Pte. Ltd.                         | ☎ +65-6282-3003<br>FAX +65-6289-3003  |
|               |                      |  | ⑬ YASKAWA ENGINEERING ASIA-PACIFIC Pte. Ltd.                     | ☎ +65-6282-1601<br>FAX +65-6382-3668  |
|               | Thailand             | Bangkok  | ⑭ YASKAWA ELECTRIC (THAILAND) Co., Ltd.                          | ☎ +66-2693-2200<br>FAX +66-2693-4200  |
|               | India                | Mumbai   | ⑮ LARSEN & TOUBRO LIMITED  | Headquarters<br>☎ +91-22-67226200<br>+91-22-27782230<br>FAX +91-22-27783032 |
| Oceania       | Australia            | Sydney (HQ)<br>Melbourne   | ⑯ ROBOTIC AUTOMATION Pty. Ltd.                                   | Headquarters<br>☎ +61-2-9748-3788<br>FAX +61-2-9748-3817                    |



# V1000

---

**DRIVE CENTER (INVERTER PLANT)**

2-13-1, Nishimiyaichi, Yukuhashi, Fukuoka, 824-8511, Japan  
Phone: 81-930-25-3844 Fax: 81-930-25-4369  
<http://www.yaskawa.co.jp>

**YASKAWA ELECTRIC CORPORATION**

New Pier Takeshiba South Tower, 1-16-1, Kaigan, Minatoku, Tokyo, 105-6891, Japan  
Phone: 81-3-5402-4502 Fax: 81-3-5402-4580  
<http://www.yaskawa.co.jp>

**YASKAWA AMERICA, INC.**

2121 Norman Drive South, Waukegan, IL 60085, U.S.A.  
Phone: (800) YASKAWA (927-5292) or 1-847-887-7000 Fax: 1-847-887-7310  
<http://www.yaskawa.com>

**YASKAWA ELÉTRICO DO BRASIL LTDA.**

Avenda Fagundes Filho, 620 Bairro Saude, São Paulo, SP04304-000, Brasil  
Phone: 55-11-3585-1100 Fax: 55-11-5581-8795  
<http://www.yaskawa.com.br>

**YASKAWA EUROPE GmbH**

Hauptstrasse 185, 65760 Eschborn, Germany  
Phone: 49-6196-569-300 Fax: 49-6196-569-398  
<http://www.yaskawa.eu.com>

**YASKAWA ELECTRIC UK LTD.**

1 Hunt Hill Orchardton Woods, Cumbernauld, G68 9LF, United Kingdom  
Phone: 44-1236-735000 Fax: 44-1236-458182  
<http://www.yaskawa.co.uk>

**YASKAWA ELECTRIC KOREA CORPORATION**

9F, Kyobo Securities Bldg., 26-4, Yeouido-dong, Yeongdeungpo-gu, Seoul, 150-737, Korea  
Phone: 82-2-784-7844 Fax: 82-2-784-8495  
<http://www.yaskawa.co.kr>

**YASKAWA ELECTRIC (SINGAPORE) PTE. LTD.**

151 Lorong Chuan, #04-01, New Tech Park, 556741, Singapore  
Phone: 65-6282-3003 Fax: 65-6289-3003  
<http://www.yaskawa.com.sg>

**YASKAWA ELECTRIC CHINA CO., LTD.**

12F, Carlton Bldg., No.21 HuangHe Road, HuangPu District, Shanghai 200003, China  
Phone: 86-21-5385-2200 Fax: 86-21-5385-3299  
<http://www.yaskawa.com.cn>

**YASKAWA ELECTRIC CHINA CO., LTD. BEIJING OFFICE**

Room 1011, Tower W3 Oriental Plaza, No.1 East Chang An Ave.,  
Dong Cheng District, Beijing, 100738, China  
Phone: 86-10-8518-4086 Fax: 86-10-8518-4082

**YASKAWA ELECTRIC TAIWAN CORPORATION**

9F, 16, Nanking E. Rd., Sec. 3, Taipei, 104, Taiwan  
Phone: 886-2-2502-5003 Fax: 886-2-2505-1280

**YASKAWA ELECTRIC INDIA PRIVATE LIMITED**

#17/A Electronics City, Hosur Road Bangalore 560 100 (Karnataka), India  
Phone: 91-80-4244-1900 Fax: 91-80-4244-1901  
<http://www.yaskawaindia.in>



YASKAWA ELECTRIC CORPORATION

In the event that the end user of this product is to be the military and said product is to be employed in any weapons systems or the manufacture thereof, the export will fall under the relevant regulations as stipulated in the Foreign Exchange and Foreign Trade Regulations. Therefore, be sure to follow all procedures and submit all relevant documentation according to any and all rules, regulations and laws that may apply.

Specifications are subject to change without notice for ongoing product modifications and improvements.

© 2007-2012 YASKAWA ELECTRIC CORPORATION. All rights reserved.

LITERATURE NO. KAEP C710606 08F

Published in Japan April 2012 07-8 0-0  
12-1-9